



Hygienic valves

GEA VARIVENT® valve type K

Operating instruction (Translation from the original language)
430BAL008372EN_6

COPYRIGHT

These Operating Instructions are the English translation of the original operating instructions in the sense of the EU Machinery Directive. This document is protected by copyright. All rights reserved. The document may not, in whole or in part, be copied, reproduced, translated or reduced to an electronic medium of machine-readable form without the express permission of GEA Tuchenhagen GmbH.

LEGAL NOTICE

Word marks

The designations VARIVENT® and T.VIS® are protected trademarks of GEA Tuchenhagen GmbH.

TABLE OF CONTENTS

1	General Information	5
1.1	Information on the Document	5
1.1.1	Binding Character of These Operating Instructions	5
1.1.2	Notes on the Illustrations	5
1.1.3	Symbols and Highlighting	5
1.2	Manufacturer address	6
1.3	Contact	6
1.4	EU Declaration of Conformity in accordance with the EC Machinery Directive 2006/42/EC	7
1.5	Translated copy of the EU - Declaration of conformity in accordance with the Pressure Equipment Directive 2006/42/EU	8
1.6	UK Declaration of Conformity for the Delivery of Machines (Safety) dated 2008	9
2	Safety	10
2.1	Intended use	10
2.1.1	Requirements for operation	10
2.1.2	Pressure equipment directive	10
2.1.3	ATEX directive	10
2.1.4	Improper operating conditions	11
2.2	Operator's Duty of Care	11
2.3	Subsequent changes	12
2.4	General safety instructions and dangers	12
2.4.1	Principles for safe operation	12
2.4.2	Environmental Protection	13
2.4.3	Electrical Equipment	13
2.5	Supplementary Regulations	13
2.6	Qualification of Staff	13
2.7	Safety equipment	15
2.7.1	Signage	15
2.8	Residual dangers	16
2.9	Hazard Areas	17
3	Description	19
3.1	Design	19
3.2	Functional description	21
3.2.1	Actuator Function	21
4	Transport and storage	22
4.1	Storage conditions	22
4.2	Transport	22
4.2.1	Scope of supply	23
5	Technical data	24
5.1	Type plate	24
5.2	Technical data	24
5.3	Resistance and permitted operating temperature of the sealing materials	25
5.4	Pipe ends - General table of measurements	27
5.5	Dimensions leakage pipe	28
5.6	Tool	28
5.7	Lubricants	29
5.8	Weights	29
6	Assembly and installation	31
6.1	Safety instructions	31
6.2	Notes on installation	31
6.3	Control head	31
6.4	Valve with Detachable Pipe Connection Elements	31
6.5	Valve with Welded Ends	32
6.6	Pneumatic connections	33
6.6.1	Air Requirement	33
6.6.2	Establishing Hose Connections	33
6.7	Electrical connection with T.VIS control top	34
7	Start-up	35
7.1	Safety instructions	35
7.2	Notes on commissioning	35

8	Operation and control	36
8.1	Safety instructions	36
9	Cleaning	37
9.1	Cleaning	37
9.1.1	Cleaning Process Examples	37
9.1.2	Cleaning effect	37
9.1.3	Cleaning the Leakage Cavity	38
9.2	Passivation	38
10	Maintenance	39
10.1	Safety instructions	39
10.2	Inspections	40
10.2.1	Product contact seals	40
10.2.2	Pneumatic connections	40
10.2.3	Electrical connections	40
10.3	Maintenance intervals	41
10.4	Prior to disassembly	41
10.5	Disassembling the Valve	41
10.5.1	Removing the Valve Insert	42
10.5.2	Separating the Valve from the Actuator	43
10.6	Maintenance	45
10.6.1	Cleaning the Valve	45
10.6.2	Replacing Seals	46
	Note on Seal Replacement	46
	Replacing the V-Ring	46
10.6.3	Lubricating seals and threads	47
10.7	Installation	48
10.7.1	O-ring	48
10.7.2	Guide rings	49
10.7.3	Spring	49
10.7.4	Leakage pipe	49
10.7.5	Torques for the Clamps and Clamp Connections	49
10.7.6	Strokes depending on size	50
11	Alarms	52
11.1	Malfunctions and remedies	52
12	Decommissioning	53
12.1	Safety instructions	53
12.2	Disposal	53
12.2.1	General notes	53
12.2.2	Valve Actuator Disposal	53
13	Spare parts list - mixproof valve K	54
14	Dimension Sheet - VARIVENT® Double Seat Valve K	66
15	Appendix	68
15.1	Lists	68
15.1.1	Abbreviations and terms	68

1 General Information

1.1 Information on the Document

The present Operating Instructions are part of the user information for the product. The Operating Instructions contain all the information you need to transport, install, commission, operate and carry out maintenance for the product.

1.1.1 Binding Character of These Operating Instructions

These Operating Instructions contain the manufacturer's instructions to the operator of the product and to all persons who work on or use the product regarding the procedures to follow.

Carefully read these Operating Instructions before starting any work on or using the product. Your personal safety and the safety of the product can only be ensured if you act as described in the Operating Instructions.

Store the Operating Instructions in such a way that they are accessible to the operator and the operating staff during the entire life cycle of the product. When the location is changed or the product is sold make sure you also provide the Operating Instructions.

1.1.2 Notes on the Illustrations

The illustrations in these Operating Instructions show the product in a simplified form. The actual design of the product can differ from the illustration. For detailed views and dimensions of the product please refer to the design documents.

1.1.3 Symbols and Highlighting

In these Operating Instructions, important information is highlighted by symbols or special formatting. The following examples illustrate the most important types of highlighting.



Danger

Warning: Fatal Injuries

Failure to observe the warning can result in serious damage to health, or even death.

- ▶ The arrow identifies a precautionary measure you have to take to avoid the hazard.



Warning: Explosions

Failure to observe the warning can result in severe explosions.

- ▶ The arrow identifies a precautionary measure you have to take to avoid the hazard.
-

 **Warning!**

Warning: Serious Injuries

Failure to observe the warning can result in serious damage to health.

- ▶ The arrow identifies a precautionary measure you have to take to avoid the hazard.

 **Caution!**

Warning: Injuries

Failure to observe the warning can result in minor or moderate damage to health.

- ▶ The arrow identifies a precautionary measure you have to take to avoid the hazard.

Notice

Warning: Damage to Property

Failure to observe the warning can result in serious damage to the component or in the vicinity of the component.

- ▶ The arrow identifies a precautionary measure you have to take to avoid the hazard.

Carry out the following steps: = Start of a set of instructions.

1. First step in a sequence of operations.
 2. Second step in a sequence of operations.
 - Result of the previous operation.
- The operation is complete, the goal has been achieved.

 **Hint!**

Further useful information.

1.2 Manufacturer address

GEA Tuchenhausen GmbH
Am Industriepark 2-10
21514 Büchen

1.3 Contact

Tel.: +49 4155 49-0
Fax: +49 4155 49-2035
flowcomponents@gea.com
www.gea.com

1.4 EU Declaration of Conformity in accordance with the EC Machinery Directive 2006/42/EC



EU Declaration of conformity within the meaning of the EC machine directive 2006/42/EC

Manufacturer: **GEA Tuchenhausen GmbH**
Am Industriepark 2-10
21514 Büchen, Germany

Hereby, we declare that the machine designated in the following

Designation: Valve with actuator

Type: VARIVENT®

by virtue of its design and construction and in the versions placed on the market by us, complies with the essential health and safety requirements of the following directive:

Relevant EC directives: 2006/42/EC EC Machinery Directive

Applicable harmonized standards, in particular: EN ISO 12100: 2010

Remarks:

- In the event of a modification to the machine that was not agreed with us, this declaration loses its validity
- Furthermore, we declare that the specific technical documentation for this machine has been drawn up in accordance with Annex VII, Part A, and undertake to forward this documentation by means of data medium upon justified request by the national authorities

Person authorised for compilation and handover of technical documentation: **GEA Tuchenhausen GmbH**
CE Documentation Officer
Am Industriepark 2-10
21514 Büchen, Germany

Büchen, 24 January 2020



 Franz Bürmann
 Managing Director



 pp/ Matthias Südel
 Head of Engineering

1/1

General Information

Translated copy of the EU - Declaration of conformity in accordance with the Pressure Equipment Directive 2006/42/EU

1.5 Translated copy of the EU - Declaration of conformity in accordance with the Pressure Equipment Directive 2006/42/EU

Manufacturer: **GEA Tuchenhagen GmbH**
Am Industriepark 2-10
21514 Büchen

We hereby declare that the machine named below

Designation: Valve with actuator

Type: VARIVENT®

due to its design and construction as well as in the versions sold by us, meet the basic safety and health requirements of the following guideline:

Relevant EC directives: 2006/42/EC EC Machinery Directive

Applicable harmonized standards, in particular: EN ISO 12100: 2010

Remarks:

- This declaration will become invalid if any alterations are made to the machine which have not been agreed with us
- We also declare that the relevant technical documentation for this machine has been prepared in accordance with Annex VII, Part A, and agree to submit the documentation on justified request of national authorities on a data carrier

Person authorised for compilation and handover of technical documentation: **GEA Tuchenhagen GmbH**
CE Documentation Officer
Am Industriepark 2-10
21514 Büchen, Germany

Büchen, 24 January 2020

Franz Bürmann
Managing Director

i.V. Matthias Südel
Head of Engineering

1.6 UK Declaration of Conformity for the Delivery of Machines (Safety) dated 2008



UK- Declaration of Conformity by Supply of Machinery (Safety) Regulations 2008

Manufacturer: **GEA Tuchenhagen GmbH**
Am Industriepark 2-10
21514 Büchen, Germany

Hereby, we declare that the machine designated in the following

Designation: Valve with actuator

Type: VARIVENT®

by virtue of its design and construction and in the versions placed on the market by us, complies with the essential health and safety requirements of the following directive:

Relevant UK legislation: Supply of Machinery (Safety) Regulations 2008

Applicable harmonized standards, in particular: EN ISO 12100: 2010 Safety of machinery - General principles for design - Risk assessment and risk reduction

- Remarks:
- In the event of a modification to the machine that was not agreed with us, this declaration loses its validity
 - Furthermore, we declare that the specific technical documentation for this machine has been drawn up in accordance with Annex VII, Part A, and undertake to forward this documentation by means of data medium upon justified request by the national authorities.

GEA Importer into UK: **GEA Mechanical Equipment UK Ltd**
 Westfalia House
 Old Wolverton Road, Old Wolverton, Milton Keynes
 MK12 5PY, United Kingdom

Person authorised for compilation and handover of technical documentation: Michael Kiely
GEA Mechanical Equipment UK Ltd
 Westfalia House
 Old Wolverton Road, Old Wolverton, Milton Keynes
 MK12 5PY, United Kingdom

Büchen, 14 March 2023



 Franz Bürmann
 Managing Director



 i.V. Matthias Südel
 Senior Director Engineering

2 Safety

2.1 Intended use

The double seat valve K is used for the mixproof separation of cleaning media at flow path intersections in pipe systems without the possibility of leakage chamber cleaning. It can be used as cleaning and gas valve in CIP systems and gas fittings.

The medium should preferably flow in the opening direction of the valve disc to avoid pipe hammers when the valve is opened or closed.

If the valve is used in the opposite direction (valve closing), a damping cylinder can be used to avoid pressure drops.

Do not install the valve in spring-opening, as this will open when there is a current or air failure and leads to product mixing.

In a closed pipe system, hydraulic pressure build-up may occur when the valve switches and result in seal damage.



Hint!

The manufacturer will not accept any liability for damage resulting from any use of the valve which is not in accordance with the designated use of the valve. The risk is borne solely by the operating company.

2.1.1 Requirements for operation

The prerequisite for reliable and safe operation of the component is proper transportation and storage as well as professional installation and assembly. Operating the unit within the limits of its designated use also involves adhering to the operating, inspection and maintenance instructions.

2.1.2 Pressure equipment directive

The component is a piece of pressure equipment (without safety function) in the sense of the pressure equipment directive 2014/68/EU. Classified according to Annex II in category 1.

According to the scope of directive 2014/34/EC, article 1, paragraph 2, f, the exception of the directive applies, due to conformity with the machine directive 2006/42/EU.

The nominal diameters smaller than DN 25 are subject to article 4, paragraph 3 of the Pressure Equipment Directive which specifies sound engineering practice. Nominal diameters \geq IPS 4"; DN 125 valid for the fluid group II.

In the event of any deviations, GEA Tuchenhausen GmbH will supply a specific Declaration of Conformity.

2.1.3 ATEX directive

In areas with an explosive atmosphere, only valves suitable for use in such areas may be used.

Refer to and observe the additional operating instructions "ATEX version valves". For details regarding the marking of valves for potentially hazardous areas also refer to the additional operating instructions "ATEX version valves".

If these valves are used in areas with a potentially explosive atmosphere, you must absolutely comply with directive 2014/34/EC with respect to all ignition hazards.

2.1.4 Improper operating conditions

The operational reliability of the valve cannot be ensured under improper operating conditions. Therefore avoid improper operating conditions.

Operating the valve is not permitted if

- Persons or objects are in the danger zone.
- Safety devices are not working or were removed.
- Malfunctions have been detected on the valve.
- Damage has been detected on the valve.
- Maintenance intervals have been exceeded.

2.2 Operator's Duty of Care

In your capacity as operator of the facility you bear a particular responsibility for the proper and safe handling of the valve in your facility. Only use the valve when it is in perfect condition to prevent danger to persons and property.

These Operating Instructions contain the information you and your staff need for the safe and reliable operation during the entire service life of the valve. Be sure to read these Operating Instructions carefully and ensure that the measures described here are observed.

The operator's duty of care includes planning the necessary safety measures and monitoring that these measures are observed. The following principles apply:

- Only allow qualified staff to work on the valve.
- The operator must authorize the staff to carry out the relevant tasks.
- Working areas and the entire environment of the valve must be neat and clean.
- The staff must wear suitable work clothing and personal protective equipment. As the operator of the facility make sure that work clothing and personal protective equipment are used.
- Instruct the staff with regard to any properties of the product which might pose a health risk and the preventative measures to be taken.
- Have a qualified first-aider on call during the operation, who can initiate the necessary first-aid measures in case of an emergency.
- Clearly define processes, lines of authority and responsibilities associated with the valve. Everybody must know what to do in case of an emergency. Instruct the staff in this respect at regular intervals.

- The signs relating to the valve must always be complete and legible. Check, clean and replace the signs as necessary at regular intervals.
- Observe the Technical Data specified and the limits of use!



Hint!

Carry out regular checks. This way you can ensure that these measures are actually observed.

2.3 Subsequent changes

You should never make any technical modifications to the valve. Otherwise you will have to undergo a new conformity process in accordance with the EC Machinery Directive on your own.

In general, only original spare parts supplied by GEA Tuchenhausen GmbH should be fitted. This ensures the reliable and economical operation of the valve.

2.4 General safety instructions and dangers

The valve is operationally reliable. It was built according to state-of-the-art science and technology.

Nevertheless, the valve can pose dangers, especially if

- the valve is not used in accordance with its intended use,
- the valve is not used correctly,
- the valve is operated under impermissible operating conditions.

2.4.1 Principles for safe operation

Dangerous situations during operation can be avoided by safety-conscious and proactive behaviour of the staff.

To ensure safe operation of the valve the following principles apply:

- The Operating Instructions must be kept ready to hand at the valve's place of use. They must be complete and in clearly legible form.
- Only use the valve for its intended use.
- The valve must be functional and in good working order. Check the condition of the valve before starting work and at regular intervals.
- Wear tight-fitting work clothing for all work on the valve.
- Ensure that nobody can get hurt on the parts of the valve.
- Immediately report any faults or noticeable changes on the valve to the person responsible.
- Never touch the pipes and the valve when these components are hot! Avoid opening the valve unless the process plants have been emptied and depressurised.
- Observe the accident prevention regulations and all local regulations.

2.4.2 Environmental Protection

Harm to the environment can be avoided by safety-conscious and proactive behaviour of the staff.

For environmental protection the following principles apply:

- Substances harmful to the environment must not be discharged into the ground or the sewage system.
- Always observe the pertinent regulations relating to waste avoidance, disposal and utilization.
- Substances harmful to the environment must be collected and stored in suitable containers. Clearly mark the containers.
- Dispose of lubricants as hazardous waste.

2.4.3 Electrical Equipment

For all work on electrical equipment, the following principles apply:

- Access to electrical equipment should only be allowed to qualified electricians. Always keep unattended switch cabinets locked.
- Modifications of the control system can affect the safe and reliable operation. Modifications are only permitted with the express permission of the manufacturer.
- After completion of all work, check that the protective devices are fully functional.

2.5 Supplementary Regulations

In addition to the instructions in this documentation the following also has to be observed:

- pertinent accident prevention regulations,
- generally accepted safety rules,
- national regulations applicable in the country of use,
- work and safety instructions applicable in the facility,
- installation and operating regulations for use in potentially explosive areas.

2.6 Qualification of Staff

This section contains information about the qualifications that staff working on the valve must have.

Operating and maintenance staff must

- have the necessary qualification to carry out their tasks,
- be instructed with regard to possible dangers,
- know and observe the safety instructions given in the documentation.

Only allow qualified electricians to carry out work on the electrical equipment or have a qualified electrician supervise the work.

Only allow specially trained staff to carry out any work on explosion-protected equipment. When working on explosion-protected equipment observe the standards DIN EN 60079-14 for gases and DIN EN 50281-1-2 for dusts.

The following minimum qualifications are required:

- Vocational training as a specialist who can work on the valve independently.
- Sufficient instruction to work on the valve under the supervision and direction of a qualified specialist.

Each member of staff must meet the following requirements to be allowed to work on the valve:

- Personal qualification for the relevant task.
- Sufficient professional qualification for the relevant task.
- Instructed with regard to the function of the valve.
- Instructed with regard to the operating sequences of the valve.
- Familiar with the safety devices and their function.
- Familiar with these Operating Instructions, especially with the safety instructions and the information which is relevant for the task on hand.
- Familiar with the basic regulations with regard to occupational health and safety and accident prevention.

For work to be carried out on the valve the following user groups are distinguished:



User groups	
Staff	Qualifications
Operating staff	<p>Adequate instruction and sound knowledge in the following areas:</p> <ul style="list-style-type: none"> • Function of the valve • Valve operating sequences • What to do in case of an emergency • Lines of authority and responsibilities with respect to the task
Maintenance staff	<p>Adequate instruction as well as sound knowledge of the design and function of the valve. Sound knowledge in the following areas:</p> <ul style="list-style-type: none"> • Mechanical equipment • Electrical equipment • Pneumatic system <p>Authorization with regard to safety engineering standards to carry out the following tasks:</p> <ul style="list-style-type: none"> • Setting devices into operation • Earthing of devices • Marking of devices <p>The relevant certificates of qualification must be submitted before work can be carried out on ATEX certified machines.</p>

2.7 Safety equipment

2.7.1 Signage

Dangerous points on the valve are indicated by warning signs, prohibition signs and mandatory signs.

The signs and notes on the valve must always be legible. Any illegible signs must be replaced immediately.

Signs on the valve	
Sign	Meaning
 Fig.1	General hazard warning
 Fig.2	Warning Crushing
 Fig.3	Explosive atmosphere hazard warning

2.8 Residual dangers

Dangerous situations can be avoided by safety-conscious and proactive behaviour of the staff and by wearing personal protective equipment.

Residual dangers on the valve and measures		
Danger	Cause	Measure
Danger to life	Inadvertent switch-on of the valve	Effectively disconnect all components, effectively prevent switch-on.
	Electric power	Observe the following safety rules: 1. Isolate from the power supply. 2. Take appropriate measures to prevent switch on. 3. Test absence of voltage. 4. Earthing and short-circuiting. 5. Cover or safeguard any adjacent live parts.
	Spring tension in the actuator	Danger to life caused by compression spring in the actuator. Do not open the actuator but return it to GEA Tuchenhausen for proper disposal.

Residual dangers on the valve and measures		
Danger	Cause	Measure
Danger of injury	Danger presented by moving or sharp-edged parts	<p>The operator must exercise caution and prudence.</p> <p>For all work:</p> <ul style="list-style-type: none"> • Wear suitable work clothing. • Never operate the machine if the cover panels are not correctly fitted. • Never open the cover panels during the operation. • Never reach into openings. <p>As a precautionary measure, wear personal protective equipment in the vicinity of the valve:</p> <ul style="list-style-type: none"> • Protective gloves • Safety shoes
Environmental damage	Operating materials with properties which are harmful to the environment	<p>For all work:</p> <ul style="list-style-type: none"> • Collect lubricants in suitable containers. • Dispose of lubricants in accordance with the pertinent regulations.

2.9 Hazard Areas

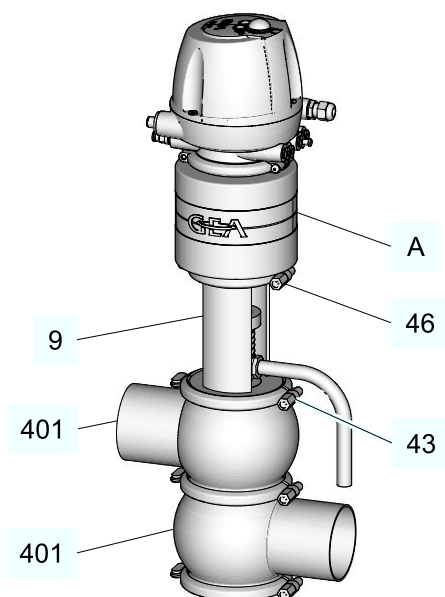

Fig.4

Please observe the following notes:

- In the event of malfunctions, shut down the valve (disconnect from the power and air supply) and secure it against being used.
- Never reach into the lantern (9) or the valve housing (402) when the valve is switching. Fingers can be crushed or cut off.
- On a spring-closing valve there is danger of injury when the clamp connections (43, 46) are opened, as the released spring pretension will suddenly lift the actuator. Therefore, release the spring tension before

detaching the clamp connections (43, 46) by supplying the actuator (A) with compressed air.

- Before starting any maintenance, servicing or repair work, disconnect the valve from the power supply and secure it against inadvertently being switched back on again.
- Only allow a qualified electrician to carry out any work on the electrical power supply.
- Check the electrical equipment of the valve at regular intervals. Immediately remedy loose connections and molten cables.
- If work on live parts cannot be avoided, call in a second person, who can operate the main switch in case of an emergency.
- The housing sockets have very sharp edges. When transporting and installing the valve be sure to wear suitable protective gloves.

3 Description

3.1 Design

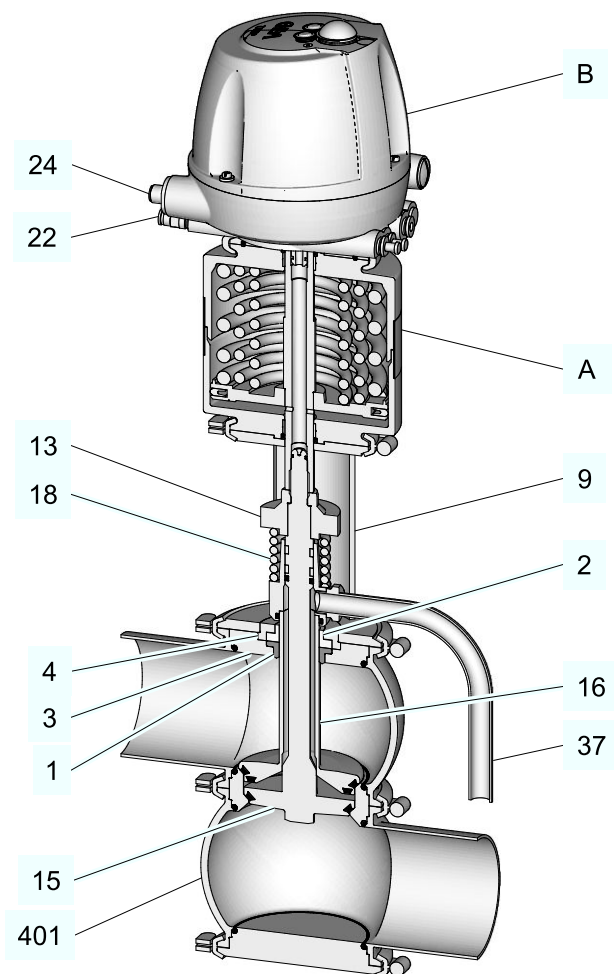

Fig.5

Design	
No.	Designation
A	Actuator
B	Control top
1	Seal ring
2	Bearing
3	Seal disk
4	Bearing disc
9	Lantern
13	Spring plate
15	Valve disk
16	Double-disk

Description
Design

Design	
No.	Designation
18	Compression spring
22	Air connection
24	Electrical connection
37	Leakage pipe
401	Valve housing

3.2 Functional description

3.2.1 Actuator Function

The actuator is of the spring-closing type (Z). The valve is closed in the non-actuated position.

Identification on the T.VIS control top once the installation (SET-UP) has been completed:

- Green steady light (1): valve in non-actuated position
- Yellow steady light (1): valve in end position (actuated position)

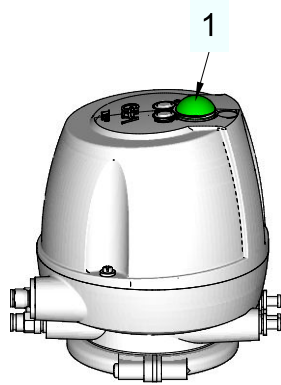

Fig.6

4 Transport and storage

4.1 Storage conditions

The valves, valve inserts or spare parts should be stored in a dry place, free of vibrations and dust, and protected from light. To avoid damage, leave the components in their original packaging if possible.

If, during transport or storage, the valve is going to be exposed to temperatures $\leq 0^{\circ}\text{C}$, it must be dried beforehand and suitable measures must be taken to protect it from damage.



Hint!

We recommend that the valve should be stored at a temperature of $\geq 5^{\circ}\text{C}$ for a period of 24 hours prior to any handling (disassembling the housings / activation of actuators) so that any ice crystals formed by condensation water can melt.

4.2 Transport

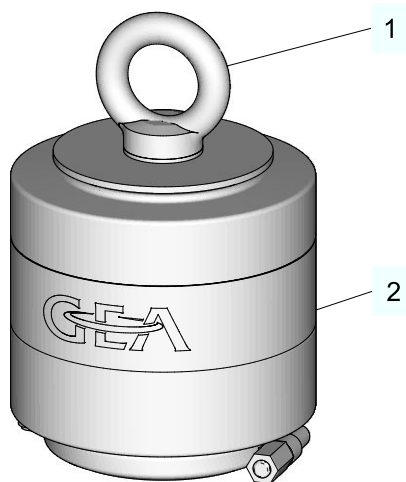

Fig.7

For transport, the following principles apply:

- When transporting the valve be sure to unscrew the control top and the switch bar from the actuator (2) and use the screwed-in eye bolt (1), material no. 221-104.98, to lift the valve.
- Only use suitable lifting gear and slings for transporting the package units/ valves.
- Observe the pictograms on the package.
- Handle valves with care to avoid damage caused by impact or careless loading and unloading. The outside synthetic materials are susceptible to breaking.
- Control tops must be protected from animal and vegetable fats.
- Only allow qualified staff to transport the valve.
- Movable parts must be properly secured.

- Only use approved, fully functional load lifting devices and lifting accessories which are suitable for the intended purpose. Observe the maximum load-bearing capacities.
- Secure the valve against slipping. Take the weight of the valve into account and the position of the point of gravity.
- Under no circumstances should anyone stand under a suspended load.
- Take care when transporting the valve. Do not grip sensitive parts of the unit to lift or push the unit or to support yourself. Avoid putting the unit down with a jerk.

4.2.1 Scope of supply

On receipt of the valve check whether

- the details on the type plate correspond to the data in the order and delivery documents,
- the equipment is complete and all components are in good order.

5 Technical data

5.1 Type plate

The type plate clearly identifies the valve.

GEA Tuchenhagen GmbH Am Industriepark 2-10, 21514 Büchen, Germany		GEA	
Type	<input type="text"/>		
Serial	<input type="text"/>	<input type="text"/>	<input type="text"/>
Mat.	<input type="text"/>	<input type="text"/>	<input type="text"/>
Air bar/psi	min. <input type="text"/>	max. <input type="text"/>	
PSI bar/psi	1 <input type="text"/>	2 <input type="text"/>	3 <input type="text"/>
			CE

The type plate provides the following key data:

Key data of the valve	
Type	Mixproof valve K
Serial	Serial number
Material	1.4404 (AISI 316L)
Control air pressure bar/psi	6 (87)
Product pressure bar/psi	5 (72.5)

5.2 Technical data

Refer to the following tables for the key technical data of the valve:

Technical data: Valve	
Designation	Description
Size	DN 25 to DN 150 1" to 6" OD 2" to 6" IPS
Material of product contact parts	Stainless steel 1.4404
Fitting position	Vertical

Technical data: Ambient temperatures	
Designation	Description
Valve	0 to 45 °C (32 ... 113 °F), standard < 0 °C (32 °F): Use control air with low dew point. Protect valve rods against freezing.
Initiator	-20 to +80 °C (-4 ... +176 °F)

Technical data: Ambient temperatures	
Designation	Description
Control top T.VIS M-20, M-15, A-15, P-15	-20 to +50 °C (-4 ... +122 °F)
Product temperature and operating temperature	depending on the sealing material

Technical data: Compressed air supply, product pressure	
Designation	Description
Air hose	
<ul style="list-style-type: none"> Metric 	Material PE-LD Outside Ø 6 mm Inside Ø 4 mm
<ul style="list-style-type: none"> Inch 	Material PA Outside Ø 6.35 mm Inside Ø 4.3 mm
Control air	acc. to ISO 8573-1
<ul style="list-style-type: none"> Solid particle content: 	Quality class 6 Particle size max. 5 µm Particle density max. 5 mg/m ³
<ul style="list-style-type: none"> Water content: 	Quality class 4 max. dew point +3 °C If the unit is used at higher altitudes or at low ambient temperatures, the dew point must be adapted accordingly.
<ul style="list-style-type: none"> Oil content: 	Quality class 3, ideally oil-free, max. 1 mg oil for 1 m ³ air
Control air pressure	6 bar (87 psi), max. 8 bar (116 psi) configuration with standard drive Alternative combinations of product pressure and control air pressure on request
Product pressure	5 bar (72.5 psi) configuration with standard drive max. 10 bar (116 psi) configuration with correspondingly designed actuator > 10 bar (145.0 psi) for static applications and on request

5.3 Resistance and permitted operating temperature of the sealing materials

Technical data

Resistance and permitted operating temperature of the sealing materials

The resistance and permitted operating temperature of the sealing materials depend on the type and temperature of the medium conveyed. The exposure time can adversely affect the service life of the seals. The sealing materials comply with the regulations of FDA 21 CFR 177.2600 or FDA 21 CFR 177.1550.

The maximum operating temperature is defined by the sealing type and its mechanical load.

Due to the versatile conditions of use (e.g. usage duration, switching frequency, type and temperature of product and cleaning agents as well as usage environment), GEA Tuchenhausen recommends that the user carries out resistance tests.

Resistance:

- + = good resistance
- o = reduced resistance
- – = no resistance

Table of sealing resistance / permitted operating temperature				
Medium	Maximum operating temperatures	Sealing material		
		EPDM	FKM	HNBR
Alkalis up to 3%	up to 80 °C (176°F)	+	o	+
Alkalis up to 5%	up to 40 °C (104°F)	+	o	o
Alkalis up to 5%	up to 80 °C (176°F)	+	–	–
Alkalis more than 5%		o	–	–
Inorganic acids up to 3%	up to 80 °C (176°F)	+	+	+
Inorganic acids up to 5%	up to 80 °C (176°F)	o	+	o
Inorganic acids up to 5%	up to 100 °C (212°F)	–	+	–
Water	up to 100 °C (176°F)	+	+	+
Steam	up to 135 °C (275°F)	+	o	o
Steam, approx. 30 min	up to 150 °C (302°F)	+	o	–
Fuels/hydrocarbons		–	+	+
Product with a fat content of max. 35%		+	+	+

Table of sealing resistance / permitted operating temperature				
Medium	Maximum operating temperatures	Sealing material		
		EPDM	FKM	HNBR
Product with a fat content of more than 35%		–	+	+
Oils		–	+	+

Sealing materials	General temperature resistance*
EPDM	-40...+135 °C (-40...275 °F)
FKM	-10...+200 °C (+14...+392 °F)
HNBR	-25...+140 °C (-13...+284 °F)
* The general resistance of the material does not correspond to the maximum operating temperature.	

5.4 Pipe ends - General table of measurements



Hint!

Not every valve is available in every size. Particulars of available sizes of valves see Chapter 5, Page 24.

Dimensions for tubes in DN				
Metric DN	Outside diameter	Wall thickness	Inside diameter	Outside diameter acc. to DIN 11850
25	29	1.5	26	x
40	41	1.5	38	x
50	53	1.5	50	x
65	70	2.0	66	x
80	85	2.0	81	x
100	104	2.0	100	x
125	129	2.0	125	x
150	154	2.0	150	x

Dimensions for tubes in Inch OD				
Inch OD	Outside diameter	Wall thickness	Inside diameter	Outside diameter acc. to BS 4825
1"	25.4	1.65	22.1	x
1.5"	38.1	1.65	34.8	x
2"	50.8	1.65	47.5	x
2.5"	63.5	1.65	60.2	x
3"	76.2	1.65	72.9	x
4"	101.6	2.11	97.38	x
6"	152.4	2.77	146.86	x

Dimensions for tubes in Inch IPS				
Inch IPS	Outside diameter	Wall thickness	Inside diameter	Outside diameter according to DIN EN ISO 1127
2"	60.3	2	56.3	x
3"	88.9	2.3	84.3	x
4"	114.3	2.3	109.7	x
6"	168.3	2.77	162.76	x

5.5 Dimensions leakage pipe

Size	Leakage pipe 90°			Leakage pipe straight		
	Outside diameter	Wall thickness	Inside diameter	Outside diameter	Wall thickness	Inside diameter
DN 25 - 100 1" - 4"	16	1.5	13	18	2.5	13
DN 125-150 6"	22	1.5	19	21.5	3.25	15

5.6 Tool

List of tools	
Tool	Material no.
Manual emergency actuator	221.310.74
Hose cutter	407-065

List of tools	
Tool	Material no.
Belt wrench	408-142
V-ring insertion tool	229-109.88
Allen key 3 mm DN 25/40/50	408-121
Open end spanner, 10 mm	408-033
Open end spanner, 13mm	408-034
Open-ended wrench, ends ground, a/f 17-19	229-119.01
Open-ended wrench, ends ground, a/f 21-23	229-119.05
Open-ended wrench, ends ground, a/f 22-24	229-119.03
Open-ended wrench, a/f 30-32	408-041
Installation mandrel DN 25 ... 50	229-109.95
Installation mandrel DN 65 ... 100	229-109.96

5.7 Lubricants

Lubricants	Material no.
Rivolta F.L.G. MD-2 (1 kg tin)	413-071
Rivolta F.L.G. MD-2 (100g tube)	413-136

5.8 Weights

Size	Weight [kg]
DN 25	9
DN 40	11
DN50	11
DN 65	18
DN 80	18
DN 100	26
DN 125	57
DN 150	65
OD 1"	9
OD 1.5"	11
OD 2"	11
OD 2.5"	17
OD 3"	18
OD 4"	26
OD 6 "	66

Technical data

Size	Weight [kg]
IPS 2"	12
IPS 3"	19
IPS 4"	27
IPS 6"	67

6 Assembly and installation

6.1 Safety instructions

Dangerous situations during assembly can be avoided by safety-conscious and proactive behaviour of the staff.

For installation, the following principles apply:

- Only properly qualified staff is allowed to install, assemble and set the valve into operation.
- Ensure that adequate working and traffic areas are available at the place of installation.
- Observe the maximum load-bearing capacity of the installation surface.
- Observe the transport instructions and markings on the part(s) to be transported.
- Remove any nails protruding from transport crates immediately after opening the crate.
- Under no circumstances should anyone stand under a suspended load.
- During assembly, the valve safety devices might not be working effectively.
- Reliably secure sections of the plant which have already been connected against inadvertently being switched on.

6.2 Notes on installation

The valve can be installed in any position. Care must be taken to ensure that the valve housing and the pipe system can drain properly. If the valve is installed in the horizontal position, pay attention that the vent hole in the actuator is aligned horizontally on one side.

To prevent damage, make sure that:

- the valve is installed in the pipe system free of tension and
- no foreign materials (e.g. tools, bolts, lubricants) are left in the system

6.3 Control head

If external valves are connected in a control top with several solenoid valves, make sure that the control air pressure in the main actuator does not fall below the operating pressure.

6.4 Valve with Detachable Pipe Connection Elements

This section describes the procedure to fit the valve.

 **Caution!**

Liquids in pipes

Danger of injury due to liquid spraying out

- ▶ Therefore, before releasing any pipe connections or hinged clamps: drain the pipe and, if necessary, clean or rinse it.
 - ▶ Separate the pipe section in which the valve is to be fitted from the rest of the piping system to prevent product entering again.
-

Carry out the following steps:

1. Fit valves with detachable pipe connection elements – using suitable connection fittings – directly into the pipe system.
- Valve is installed.

6.5 Valve with Welded Ends

This section describes the welding procedure for the valve housing.

 **Warning!**

Spring tension in the valve

Danger of injury when opening the clamp connections on the actuator or on the housing as the released spring pretension will suddenly lift the actuator.

- ▶ Therefore, release the spring tension before detaching the clamp connections by pressurizing the actuator with compressed air at max. 8 bar.
-

Notice

Seals are wearing parts

Old seals will cause malfunction of the valve

- ▶ When fitting the valve be sure to fit new housing O-rings.
-

Carry out the following steps:

1. Release the spring tension.
2. Remove the valve insert, see chapter Section 10.5, Page 41.
3. Weld the housing, without sealing rings, into position, ensuring that the connection is free of stress.
4. Fit the housing into place and tack it.
5. To avoid welding distortions, always seal the housing before welding.
6. Flush the housing with forming gas from the inside to push the oxygen out of the system.
7. Weld the housing into the pipe system; use welding filler if necessary. When technically possible, use the WIG-Orbital welding process with pulse configuration, according to guidelines EHEDG documentation. 35.
8. Passivate the seam after welding.
9. Assemble the valve and depressurize the actuator..

10. Fit the seals.
 → The valve disk is lowered.
 → Install the valve with welded ends.



Hint!

Welding method: We recommend using the automatic orbital welding method. All welding work should only be performed by certified welders or machine operators (orbital welders).

Housing O-rings: When assembling the valve always replace the housing O-rings to ensure that the valve is tight.

6.6 Pneumatic connections

6.6.1 Air Requirement

Actuator type	Actuator Ø [mm]	Air requirement (dm ³ _n /Stroke) dm ³ _n at 1.01325 bar at 0 °C as per DIN 1343	Use
A...	98	0.16	DN 25 - DN 100 1" - 4" OD 2" - 4" IPS
B...	109	0.26	
C...	135	0.42	
D...	170	0.70	
E...	210	1.10	
R... ¹	170	1.60	
S... ¹	210	2.00	
T... ¹	210	2.20	DN 125 + DN 150 6" OD, 6" IPS
D... ⁶	170	1.30	
E... ⁶	210	2.00	
S... ⁶	261	3.20	
T... ⁶ ¹	210	4.00	
U... ⁶ ¹	261	5.20	

¹ Actuators with booster cylinder for increasing the pneumatic actuating force when lower control air pressures are used

6.6.2 Establishing Hose Connections

To ensure reliable operation, the compressed air hoses must be cut exactly square.

Tools required:

- A hose cutter

Carry out the following steps:

1. Shut off the compressed air supply.
2. Use the hose cutter to cut the pneumatic hoses square.
3. Push the air hose into the air connector on the control top.
4. Re-open the compressed air supply.

→ Establish a hose connection.

6.7 Electrical connection with T.VIS control top



Danger

Live parts

Electrical shock can result in serious personal injury or death.

- ▶ Only allow properly qualified staff to carry out work on the electrical equipment.
- ▶ Prior to establishing electrical connections check the maximum permissible operating voltage.



Explosive gases or dusts

An explosion can result in serious personal injury or death.

- ▶ Observe the installation and operating regulations for use in potentially explosive areas.

Carry out the following steps:

1. Connect in accordance with the connection diagram and the instructions in the corresponding operating instructions for control tops T.VIS M-15, A-15 or T.VIS P-15.

→ Done



Hint!

The proximity switches are factory set. During transport and installation it can happen that the settings are changed, so that readjustment may be required (see the Operating Instructions for the control top).

7 Start-up

7.1 Safety instructions

Initial commissioning

For initial commissioning, the following principles apply:

- Take protective measures against dangerous contact voltages in accordance with pertinent regulations.
- The valve must be completely assembled and correctly adjusted. All screw connections must be securely tightened. All electrical cables must be installed correctly.
- Reliably secure machine parts which have already been connected against inadvertently being switched on.
- Relubricate all lubricating points.
- Make sure lubricants are used properly.
- After conversion of the valve, residual risks must be reassessed.

Setting into Operation

For commissioning, the following principles apply:

- Only allow properly qualified staff to set the valve into operation.
- Establish all connections correctly.
- The safety devices for the valve must be complete, fully functional and in perfect condition. Check the function before starting any work.
- When the valve is switched on, the danger zones must be free.
- Remove any liquids that have escaped without leaving residues.

7.2 Notes on commissioning

Before starting commissioning observe the following:

- Make sure that there are no foreign materials in the system.
- Actuate the valve once by applying compressed air.
- Clean the pipe system prior to the first product run.
- During commissioning, regularly check all sealing points for leaks. Replace defective seals.

8 Operation and control

8.1 Safety instructions

Dangerous situations during operation can be avoided by safety-conscious and proactive behaviour of the staff.

For operation, the following principles apply:

- Monitor the valve during the operation.
- Safety devices must not be changed, removed or taken out of service. Check all safety devices at regular intervals.
- All guards and hoods must be fitted as intended.
- The place of installation of the valve must be adequately ventilated at all times.
- Structural alterations of the valve are not permitted. Immediately report any changes on the valve to the person responsible.
- Always keep danger zones clear. Do not leave any objects in the danger zone. Only allow persons to enter the danger zone when the machine is de-energized.
- Regularly check that all emergency stop devices are working correctly.

9 Cleaning

9.1 Cleaning

All parts in contact with product must be cleaned at regular intervals. Always observe the safety data sheets issued by the cleaning agent manufacturers. Only use cleaning agents which do not cause damage to the seals and the inner parts of the valve. When the pipe is cleaned, the cleaning medium also flows through and cleans the valve housings.

With respect to the cleaning method and parameters like detergents, temperatures, times, and intervals, the component manufacturer can merely make recommendations but cannot provide any generally applicable details. Method and parameters should be determined and defined by the operator in accordance with the relevant process and product.

The cleaning effect must be checked regularly by the operator!

9.1.1 Cleaning Process Examples

Typical Cleaning Parameters in Dairy Operations

Example of a two-phase cleaning process:

- Sodium hydroxide solution and sodium hydroxide based combination products in concentrations from 0.5% to 2.5% at 75 °C (167 °F) to 80 °C (176 °F).
- Phosphoric or nitric acid, and combination products based thereon in the concentrations of 0.3 to 1.5% at approx. 65 °C (149 °F).

Example of a cleaning operation in one cleaning step:

- Formic acid and formic acid-based combination products at up to 85 °C (185 °F).

Typical Cleaning Parameters in Breweries

- Sodium hydroxide solution and sodium hydroxide based combination products in concentrations of 1% to 4% at about 85 °C (185 °F).
- Phosphoric or nitric acid, and combination products based thereon in the concentrations of 0.3 to 1.5% at 20 °C (68 °F).

9.1.2 Cleaning effect

The cleaning effect depends on the following factors:

- Temperature
- Time
- Mechanics
- Chemicals
- Degree of soiling

These factors can be combined in such a way as to make an optimal cleaning result probable.

9.1.3 Cleaning the Leakage Cavity

Cleaning the leakage chamber of the double seat valve type K is not possible. This valve is therefore primarily used in the CIP and gas area. The switching leaks are discharged via the leakage pipe in the lantern.

9.2 Passivation

Before commissioning a plant, passivation is commonly carried out for long pipes and tanks.

Valve blocks are usually excepted from this. Passivation is typically performed using nitric acid (HNO_3) at approx. 80 °C (176 °F) at a concentration of 3 % and a contact time of 6 to 8 hours.

10 Maintenance

10.1 Safety instructions

Maintenance and repair

Before starting any maintenance and repair work on the electrical devices of the valve, carry out the following steps in accordance with the "5 safety rules":

- Isolate from the power supply
- Take appropriate measures to prevent switch on
- Test absence of voltage
- Earthing and short-circuiting
- Cover or safeguard any adjacent live parts.

For maintenance and repair, the following principles apply:

- Observe the intervals specified in the maintenance schedule.
- Only allow qualified staff to carry out maintenance or repair work on the valve.
- Before starting any maintenance or repair work, the valve must be switched off and secured against being switched back on. Work may only be started once any residual energy has been discharged.
- Block access for unauthorized persons. Put up notice signs which draw attention to the maintenance or repair work going on.
- Do not climb on the valve. Use suitable access aids and working platforms.
- Wear suitable protective clothing.
- Only use suitable and undamaged tools to carry out maintenance work.
- When replacing parts only use approved, fully functional load lifting devices and lifting accessories which are suitable for the intended purpose.
- Before setting the magnetic separator back into operation, refit all safety devices as originally provided in the factory. Then check that all safety devices are working correctly.
- Make sure lubricants are used properly.
- Check pipes are firmly secured, also check for leaks and damage.
- Check that all emergency stop devices are working correctly.

Disassembly

For disassembly, the following principles apply:

- Only allow qualified staff to disassemble the valve.
- Before starting disassembly, the valve must be switched off and secured against being switched back on. Work may only be started once any residual energy has been discharged.
- Disconnect all power and utility lines.
- Markings, e.g. on lines, must not be removed.

- Do not climb on the valve. Use suitable access aids and working platforms.
- Mark the lines (if unmarked) prior to disassembly to ensure they are not confused when re-assembling.
- Protect open line ends with blind plugs against ingress of dirt.
- Pack sensitive parts separately.
- For longer periods of standstill, observe the storage conditions, see Section 4.1, Page 22.

10.2 Inspections

Between the maintenance periods, the valves must be checked for leakage and proper function.

10.2.1 Product contact seals

Carry out the following steps:

1. Regularly check:
 - Stem seal between upper housing and lantern
 - V-ring in the valve disks
 - O-rings between the valve housings

→ Done

10.2.2 Pneumatic connections

Carry out the following steps:

1. Check the operating pressure at the pressure reducing and filter station.
2. Regularly clean the air filter in the filter station.
3. Check that the air hoses sit firmly in the air connections.
4. Check the lines for kinks and leaks.
5. Check the solenoid valves for proper function.

→ Done

10.2.3 Electrical connections

Carry out the following steps:

1. Check that the union nut on the cable gland is tight
2. Check that the cable connections are firmly secured.
3. Check the solenoid valves for proper function.
4. Check that the proximity switch connections are clean.

→ Done



Hint!

The electrical cable must be long enough to allow the control top to be removed via the switch bar.

10.3 Maintenance intervals

To ensure the highest operational reliability of the magnetic separator, all wearing parts should be replaced at longer intervals.

The actual maintenance intervals can only be determined by the user since they depend on the operating conditions, for instance:

- daily period of use,
- switching frequency,
- type and temperature of the product,
- type and temperature of the cleaning solution,
- ambient conditions.

Maintenance intervals	
Applications	Maintenance intervals (guideline values)
Media at temperatures of 60 °C to 130 °C (140 °F to 266 °F)	approx. every 3 months
Media at temperatures of < 60 °C (< 140 °F)	approx. every 12 months

10.4 Prior to disassembly

Prerequisite:

- Make sure that during maintenance and repair work no process is in operation in the area concerned.

Carry out the following steps:

1. Drain all pipe system elements that lead to the valve and, if necessary, clean or rinse them.
2. Shut off the control air supply.
3. Disconnect the power supply.
4. Take the valve out of the pipe section, with all housings and housing connections if possible.

→ Done

10.5 Disassembling the Valve

10.5.1 Removing the Valve Insert

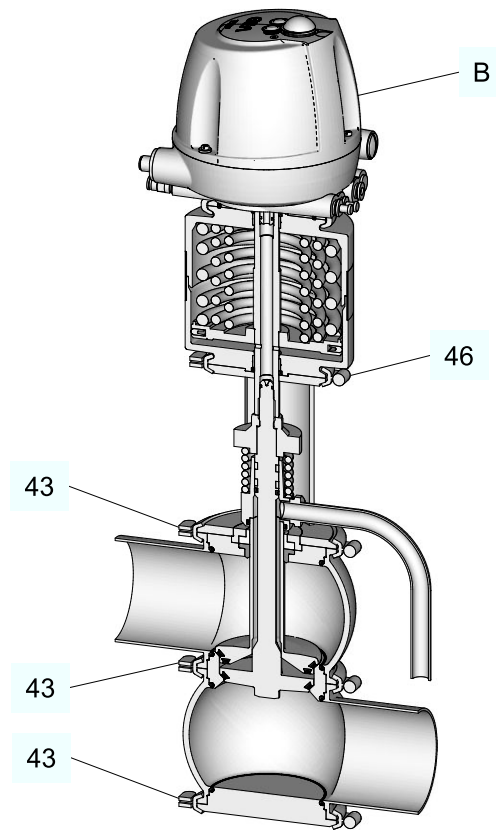

Fig.8

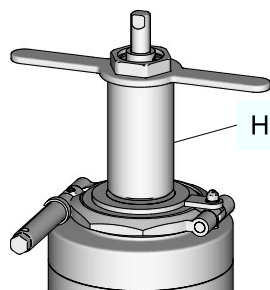

Fig.9

Requirement:

- No solenoid valve must be actuated electrically or manually.
- The pneumatic and electrical connections on the plant side can remain on the control top.
- During maintenance and servicing work no process must be in operation in the area concerned.
- All pipe system elements that lead to the valve must be drained and, if necessary, cleaned or rinsed.
- Control air must be blocked if it is not required for removal.
- Power supply must be interrupted.

- If possible, take the valve out of the pipe section, with all housings and housing connections

Notice

The permanent magnet on the switch bar is fragile.

Damage to the permanent magnet.

- ▶ Protect the permanent magnet against impact stress.



Warning!

Spring tension in the valve

Danger of injury when detaching the clamp connections (43, 46) as the released spring pretension will suddenly lift the actuator.

- ▶ Before releasing the clamp joins, pretension the actuator using a manual emergency actuator (H).

Carry out the following steps:

1. Unscrew the control top (B).
 2. Pre-tension the actuator with an manual emergency actuator (H) (material no. 221.310.74) before unscrewing the valve disk.
 3. Remove the clamp connection (43) between housing and lantern.
 4. Vent the actuator.
 5. Withdraw the valve from the housing.
- The valve insert has been removed.

10.5.2 Separating the Valve from the Actuator

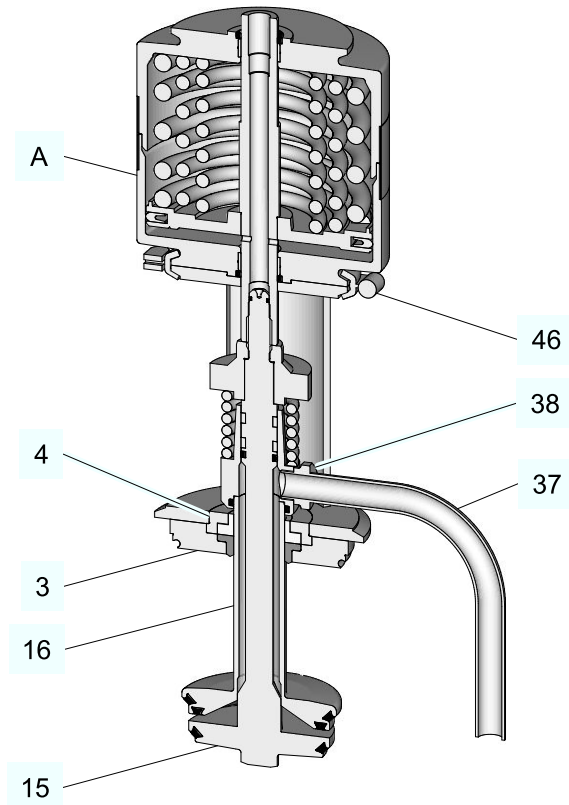

Fig.10

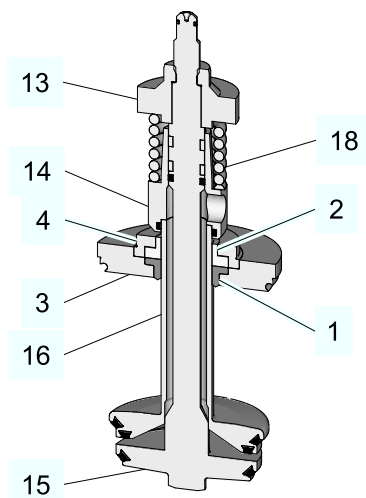

Fig.11

Notice

Sensitive valve parts

Damage to valve parts.

► Protect the valve parts against impact stress.

Carry out the following steps:

1. Unscrew the hexagon nuts (38) and leakage pipe (37).
2. Remove the clamp connection (46) between drive and lamp.

3. Secure actuator (A) with a strap wrench. Place the jaw wrench onto the spanner surface of the valve disk (15) and remove the actuator.
 4. Pull the valve insert out of the lantern.
! The bearing disc (4) and the seal disks (3) must not hit the rod (16) of double disk when the valve insert is withdrawn.
 5. Hold the valve disk (15) at the spanner surface. Unscrew the spring plate (13) with a jaw wrench.
 6. Remove the pressurised spring (18), leakage outlet (14), bearing disc (4), bearings (2), seal ring (1) with the seal disk (3) and double-disk (16) from the valve disk (15).
- Done.

10.6 Maintenance

10.6.1 Cleaning the Valve

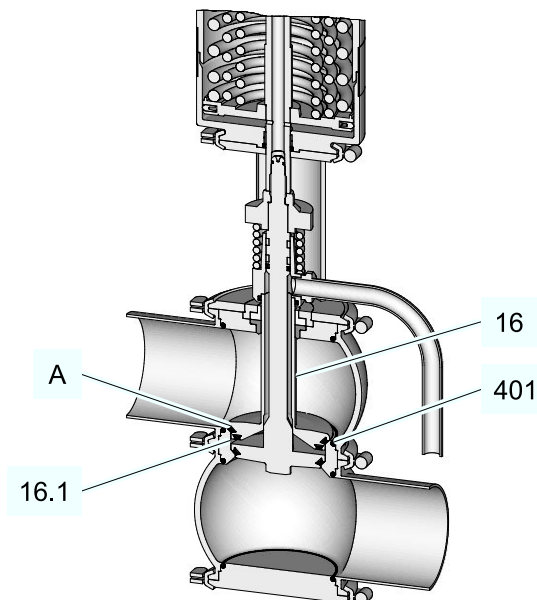

Fig.12

Notice

The rod of the valve disk (16), the housing seat (401), the valve seat (16.1) and the V-ring groove (A) are precision parts.

Damage to these parts can result in malfunction.

► Handle the valve with care!

Notice

Damage to the valve

Damage to these parts can result in malfunction.

- ▶ Observe the safety information sheets issued by the detergent manufacturers!
 - ▶ Only use detergents which are non-abrasive and not aggressive towards stainless steel.
-

Carry out the following steps:

1. Disassemble the valve, see Section 10.5, Page 41.
 2. Carefully clean the individual parts.
- Done

10.6.2 Replacing Seals

10.6.2.1 Note on Seal Replacement

Replace defective seals, but always fit new housing O-rings to ensure the tightness of the valve. Always use original spare parts.

10.6.2.2 Replacing the V-Ring

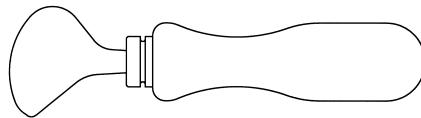

Fig.13: V-ring insertion tool

Prerequisite:

- Insert V-Ring without grease. To facilitate fitting, use water with a drop of washing-up liquid to remove the surface tension. In order that no rust is transferred, the washing-up liquid solution must be made up in a ceramic, plastic, or stainless steel container.

Tools required:

- V-ring insertion tool

Caution!

Danger of injury!

The scriber can slip off when the V-ring is removed

- ▶ Grip the valve disk in a vice with protected jaws.
 - ▶ Unscrew the curved side of the scriber.
-

Carry out the following steps:

1. Put a scriber into the V-ring and take it out.

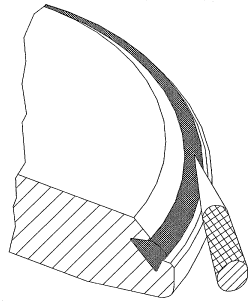

Fig.14

2. Before fitting, wet the V-ring on the side not in contact with product (rear side). Pay attention that water does not drip into the V-ring groove on the valve disk.
3. Air out the valve upon connection (22).
4. Put in the V-ring. Make sure the installation position of the V-ring is correct (see illustration).

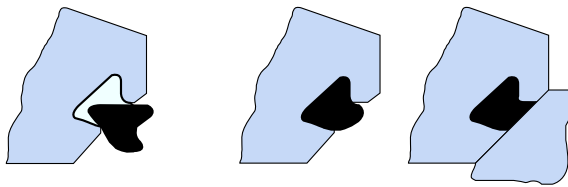

Fig.15

5. Use the insertion tool to press in the V-ring – evenly press in at several opposite points along the circumference.

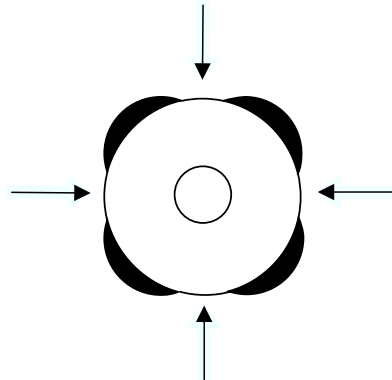

Fig.16

6. Insert the V-ring evenly.
 7. Replace all the other seals identified in the spare parts lists.
- Done



Hint!

Used seals must not be used again, since the proper function of the seal can then no longer be ensured.

10.6.3 Lubricating seals and threads

⚠ Caution!

Damage to seals and threads

Stainless steel threads tend to seize and cold weld and must be greased. Damage to seals and threads can result in malfunction.

- ▶ Ensure that an adequate film of lubricant is applied. No grease residues must be visible once the valve has been assembled completely.
- ▶ For product contact seals only use suitable greases and oils.
- ▶ Observe the safety data sheets issued by the lubricant manufacturer!

Carry out the following steps:

1. Apply a light film of lubricant to all threads.
2. Grease all seals – including the O-rings at the top and bottom of the actuator piston stem – very thinly.

! Do not grease V-rings

→ Done

i Hint!

GEA Tuchenhagen recommends Rivolta F.L.G. MD-2 and PARALIQ GTE 703. These lubricants are approved for foodstuff and are resistant to beer froth. They have the NSF-H1 (USDA H1) registration. They do not affect the taste or the consistency of the products and are compatible with the seals in contact with product.

Rivolta F.L.G. MD-2 can be ordered from GEA Tuchenhagen. Using other types of grease can result in malfunctions or in premature seal failure. The warranty will also become null and void.

A Manufacturer's Declaration for these products can be obtained from GEA Tuchenhagen if required.

A thin film of grease is required on the seals to ensure the proper function of the fittings. It reduces friction and extends the service life of the seals. This is absolutely harmless from a health and hygienic point of view.

Running dry must be avoided!

10.7 Installation

Assemble the valve in reverse order of disassembly. Observe the notes and instructions given in the following sections when doing so.

10.7.1 O-ring

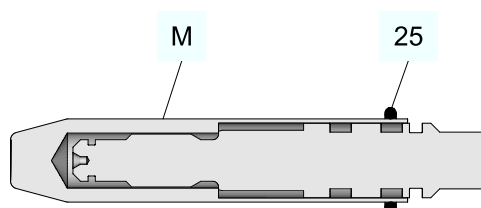

Fig.17

Mount the O-ring (25) using the installation mandrel.

10.7.2 Guide rings

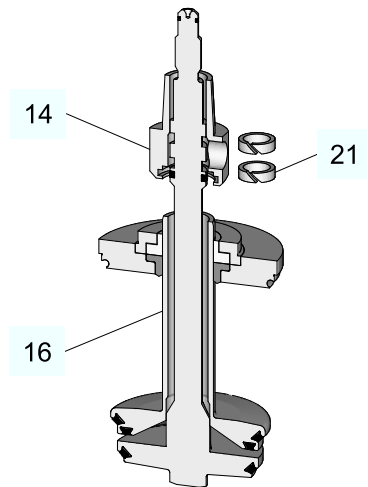

Fig.18

After installing the double disk (16) and the leakage outlet (14), push the guide ring (21) through the opening in the leakage outlet and install.

10.7.3 Spring

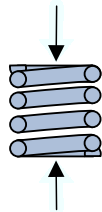

Fig.19

Before the spring is placed into the cleaning hood, both surface ends must be greased.

10.7.4 Leakage pipe

Before installation, rub the sealing pin (pipetite stick, material no. 418-017) several times over the male thread of the leakage pipe. The spreadable sealant presses itself between the threads when screwed together and seals permanently and without hardening.

10.7.5 Torques for the Clamps and Clamp Connections

Tighten the clamp connection and semi-rings on the valve to the torques specified in the table.

Torques		[Nm]	[lbft]
Clamps on the control top		1	0.7
Clamp connection cast half rings	M6	9	6.6
Clamp connection cast half rings	M8	22	16.2
Cast clamps	M10	45	33

10.7.6 Strokes depending on size

Setting the valve stroke

Carry out the following steps:

1. Actuate the valve with compressed air.
2. Check the stroke of the valve in accordance with (Page 50).

→ The stroke is set.

Valve stroke depending on size

Valve Stroke	
Valve size	Valve stroke [mm]
Metric	
25	20
40	25
50	31
65	30
80	30
100	30
125	60
150	60
Inch OD	
1"	16
1.5"	25
2"	31.5
2.5"	31
3"	29
4"	30.5
6"	57
Inch IPS	

Valve Stroke	
Valve size	Valve stroke [mm]
2"	30
3"	30
4"	30
6"	60

11 Alarms

11.1 Malfunctions and remedies

In the event of malfunctions immediately deactivate the valve and secure it against inadvertent reactivation. Malfunctions may only be remedied by qualified staff, who must observe the safety precautions.

Malfunction	Cause	Remedy
Valve does not work	Fault in the controller	Check the system configuration
	No compressed air or compressed air too low	Check compressed air supply and check air hoses for free passage and air tightness
	Fault in the electrical system	Check actuation / external controller and routing of electrical lines
	Solenoid valve defective	Replace the solenoid valve
Valve does not close	Dirt/foreign material between valve seat and valve disk	Clean valve housing and valve seat
Valve closes too slowly	O-rings in the actuator and control top are dry (friction losses)	Grease O-rings
Leakage in the area of the valve housing	Housing O-rings defective	Removing the valve Replace the housing O-rings
Leakage in the lantern	Seal ring defective	Replace the seal ring
Leakage in the leakage cavity	V-rings defective	Replace the V-rings

12 Decommissioning

12.1 Safety instructions

For shutting down, the following principles apply:

- Switch off the compressed air.
- Switch off the valve via the main switch.
- Padlock the main switch (if fitted) in the off position to prevent it from being switched back on. The key to the padlock must be deposited with the person responsible until the machine is restarted.
- For longer periods of standstill, observe the storage conditions, see Section 4.1, Page 22.

12.2 Disposal

12.2.1 General notes

Dispose of the valve in an environmentally friendly manner. Observe the statutory waste disposal regulations applicable at the place of installation.

The valve is made of the following materials:

- Metals
- Synthetic materials
- Electronic parts
- Lubricants containing oil and grease

Separate the different materials and dispose of them correctly sorted. Also observe the instructions regarding disposal in the operating instructions for the individual components.

12.2.2 Valve Actuator Disposal



Danger

The spring forces in the actuator can be as high as 24 kN.

The pre-stressed spring can cause serious personal injury or death.

- ▶ Never open the actuator.
- ▶ GEA Tuchenhausen accepts unopened actuators and arranges for proper disposal free of charge.

Carry out the following steps:

1. Remove the actuator.
 2. Pack the actuator safely and send it to GEA Tuchenhausen GmbH.
- Done

13 Spare parts list - mixproof valve K

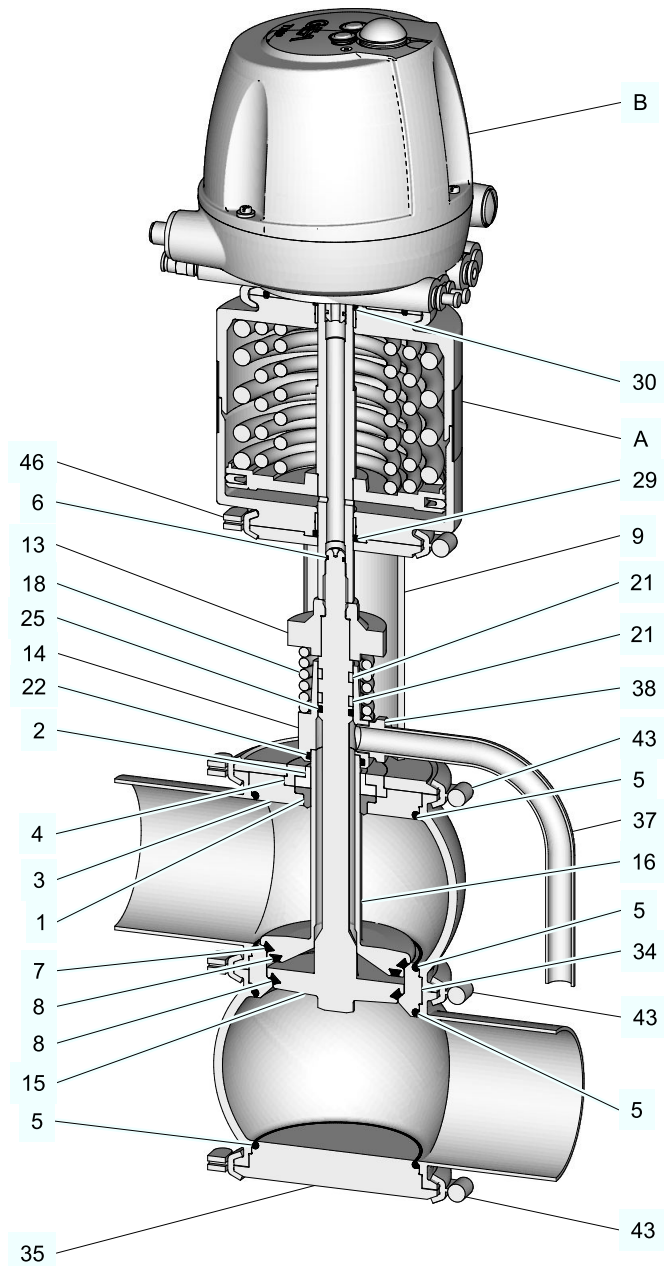

Fig.20

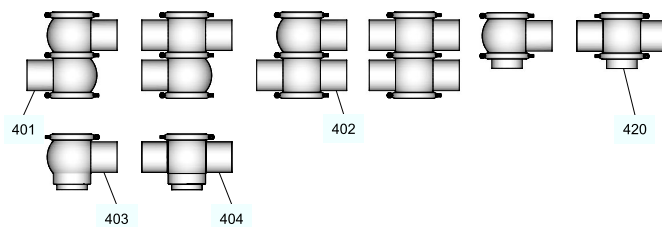

Fig.21

Item	Designation	Material	DN 25	DN 40	DN 50	DN 65
Seal set complete 1)		EPDM	221-304.12	221-304.13	221-304.13	221-304.14
		FKM	221-519.32	221-519.33	221-519.33	221-519.34
		HNBR	221-519.75	221-519.76	221-519.76	221-519.77
1*	Seal ring	EPDM	924-084	924-084	924-084	924-085
		FKM	924-082	924-082	924-082	924-083
		HNBR	924-311	924-311	924-311	924-313
2	Bearing	PTFE/carbon	935-001	935-001	935-001	935-002
3	Seal disk	1.4404	221-141.01	221-141.02	221-141.02	221-141.03
4	Bearing disc	1.4301	221-142.01	221-142.02	221-142.02	221-142.03
5*	O-ring	EPDM	930-309	930-144	930-144	930-150
		FKM	930-168	930-171	930-171	930-176
		HNBR	930-637	930-633	930-633	930-634
6*	O-ring	NBR	930-004	930-004	930-004	930-004
**7*	V-ring AX	EPDM	932-046	932-021	932-021	932-024
		FKM	932-030	932-033	932-033	932-035
		HNBR	932-087	932-088	932-088	932-090
**8*	V-ring AX	EPDM	932-017	932-019	932-019	932-023
		FKM	932-029	932-032	932-032	932-034
		HNBR	932-085	932-084	932-084	932-089
9	Lantern	1.4301	221-121.01	221-121.02	221-121.02	221-121.03
13	Spring plate K	1.4301	221-155.06	221-155.04	221-155.04	221-155.04
14	Leakage outlet	1.4301	221-153.04	221-153.01	221-153.01	221-153.02
15	Valve disc K	1.4404	221-124.01	221-124.02	221-124.10	221-124.04
16	Double-disk K	1.4404	221-125.01	221-125.02	221-125.10	221-125.04
18	Compression spring	1.4310	931-208	931-001	931-001	931-249
21	Guide ring	Turcite	935-022	935-022	935-022	935-010
22*	O-ring	EPDM	930-268	930-268	930-268	930-243
		FKM	930-164	930-164	930-164	930-244
		HNBR	930-639	930-639	930-639	930-640
25*	O-ring	EPDM	930-311	930-311	930-311	930-276
		FKM	930-335	930-335	930-335	930-277
		HNBR	930-803	930-803	930-803	930-627
29*	O-ring	NBR	930-026	930-026	930-026	930-026
30*	O-ring	NBR	930-026	930-026	930-026	930-026
34	Seat ring	1.4404	221-108.01	221-108.02	221-108.02	221-108.03
35	Blanking plate	1.4301	221-144.01	221-144.02	221-144.02	221-144.03
37	Leakage pipe 90°	1.4301	221-154.07	221-154.07	221-154.07	221-154.07
	Leakage pipe straight	1.4301	221-154.03	221-154.03	221-154.03	221-154.03
38	Hexagon nut	1.4301	709-014	709-014	709-014	709-014

Spare parts list - mixproof valve K

Item	Designation	Material	DN 25	DN 40	DN 50	DN 65
43	Clamp join KL	1.4401	221-507.02	221-507.04	221-507.04	221-507.09
46	Clamp join KL	1.4401	221-507.06	221-507.06	221-507.06	221-507.06
401	Housing V1	1.4404	221-101.19	221-101.21	221-101.22	221-101.05
402	Housing V2	1.4404	221-102.41	221-102.43	221-102.44	221-102.05
403	Housing KL	1.4404	221-438.02	221-438.01	221-438.03	221-438.04
404	Housing KT	1.4404	221-439.02	221-439.01	221-439.03	221-439.04
420	Housing connection	1.4404	221-571.02	221-571.04	221-571.06	221-571.09
A	Actuator VARIVENT®	See parts list/dimensions sheet for VARIVENT® actuator				
B	Control top T.VIS®	See parts list for control top T.VIS®				
Grease RIVOLTA F.L.G. 100g tube not included with seal set. ** Do not grease item 7 and 8 1) The seal set contains items 1, 5, 6, 7, 8, 22, 25, 29 and 30					413-136	

Item	Designation	Material	DN 80	DN 100	DN 125	DN 150
Seal set complete 1)		EPDM	221-304.14	221-304.15	221-304.16	221-304.17
		FKM	221-519.34	221-519.35	221-519.36	221-519.37
		HNBR	221-519.77	221-004176	--	--
1*	Seal ring	EPDM	924-085	924-085	924-088	924-088
		FKM	924-083	924-083	924-087	924-087
		HNBR	924-313	924-313	--	--
2	Bearing	PTFE/carbon	935-002	935-002	935-003	935-003
3	Seal disk	1.4404	221-141.03	221-141.04	221-141.07	221-141.05
4	Bearing disc	1.4301	221-142.03	221-142.03	221-142.04	221-142.04
5*	O-ring	EPDM	930-150	930-156	930-372	930-260
		FKM	930-176	930-178	930-409	930-259
		HNBR	930-634	930-863	--	--
6*	O-ring	NBR	930-004	930-004	930-007	930-007
**7*	V-ring AX	EPDM	932-024	932-028	932-060	932-042
		FKM	932-035	932-039	932-062	932-041
		HNBR	932-090	932-100	--	--
**8*	V-ring AX	EPDM	932-023	932-027	932-059	932-045
		FKM	932-034	932-038	932-063	932-044
		HNBR	932-089	932-099	--	--
9	Lantern	1.4301	221-121.03	221-121.04	221-121.06	221-121.22
13	Spring plate K	1.4301	221-155.04	221-155.04	221-155.02	221-155.02
14	Leakage outlet	1.4301	221-153.02	221-153.02	221-153.03	221-153.03
15	Valve disc K	1.4404	221-124.05	221-124.06	221-124.09	221-124.08
16	Double-disk K	1.4404	221-125.05	221-125.06	221-125.09	221-125.08
18	Compression spring	1.4310	931-249	931-002	931-093	931-093
21	Guide ring	Turcite	935-010	935-010	935-018	935-018
22*	O-ring	EPDM	930-243	930-243	930-356	930-356
		FKM	930-244	930-244	930-357	930-357
		HNBR	930-640	930-640	--	--
25*	O-ring	EPDM	930-276	930-276	930-270	930-270
		FKM	930-277	930-277	930-163	930-163
		HNBR	930-627	930-627	930-637	930-637
29*	O-ring	NBR	930-026	930-026	930-035	930-035
30*	O-ring	NBR	930-026	930-026	930-026	930-026
34	Seat ring	1.4404	221-108.03	221-108.04	221-108.12	221-108.06
35	Blanking plate	1.4301	221-144.03	221-144.04	221-144.06	221-144.05
37	Leakage pipe 90°	1.4301	221-154.07	221-154.07	221-154.09	221-154.09
	Leakage pipe straight	1.4301	221-154.03	221-154.03	221-154.06	221-154.06
38	Hexagon nut	1.4301	709-014	709-014	709-013	709-013

Spare parts list - mixproof valve K

Item	Designation	Material	DN 80	DN 100	DN 125	DN 150
43	Clamp join KL	1.4401	221-507.09	221-507.11	221-507.13	221-507.14
46	Clamp join KL	1.4401	221-507.06	221-507.06	221-507.11	221-507.11
401	Housing V1	1.4404	221-101.06	221-101.07	221-101.18	221-101.66
402	Housing V2	1.4404	221-102.06	221-102.07	221-102.29	221-102.09
403	Housing KL	1.4404	221-438.05	221-438.06	221-438.17	221-438.24
404	Housing KT	1.4404	221-439.05	221-439.06	221-439.17	221-439.24
420	Housing connection	1.4404	221-571.11	221-571.14	221-571.16	221-571.19
A	Actuator VARIVENT®	See parts list/dimensions sheet for VARIVENT® actuator				
B	Control top T.VIS®	See parts list for control top T.VIS®				
Grease RIVOLTA F.L.G. 100g tube not included with seal set. ** Do not grease item 7 and 8 1) The seal set contains items 1, 5, 6, 7, 8, 22, 25, 29 and 30					413-136	

Spare parts list - mixproof valve K

Item	Designation	Material	1" OD	1.5" OD	2" OD	2.5" OD
Seal set complete 1)		EPDM	221-304.12	221-304.03	221-304.13	221-304.14
		FKM	221-519.32	221-519.33	221-519.33	221-519.34
		HNBR	221-519.75	221-519.76	221-519.76	221-519.77
1*	Seal ring	EPDM	924-084	924-084	924-084	924-085
		FKM	924-082	924-082	924-082	924-083
		HNBR	924-311	924-311	924-311	924-313
2	Bearing	PTFE/carbon	935-001	935-001	935-001	935-002
3	Seal disk	1.4404	221-141.01	221-141.02	221-141.02	221-141.03
4	Bearing disc	1.4301	221-142.01	221-142.02	221-142.02	221-142.03
5*	O-ring	EPDM	930-309	930-144	930-144	930-150
		FKM	930-168	930-171	930-171	930-176
		HNBR	930-632	930-633	930-633	930-634
6*	O-ring	NBR	930-004	930-004	930-004	930-004
**7*	V-ring AX	EPDM	932-046	932-021	932-021	932-024
		FKM	932-030	932-033	932-033	932-035
		HNBR	932-087	932-088	932-088	932-090
**8*	V-ring AX	EPDM	932-017	932-019	932-019	932-023
		FKM	932-029	932-032	932-032	932-034
		HNBR	932-085	932-084	932-084	932-089
9	Lantern	1.4301	221-121.01	221-121.07	221-121.07	221-121.08
13	Spring plate K	1.4301	221-155.06	221-155.04	221-155.04	221-155.04
14	Leakage outlet	1.4301	221-153.04	221-153.0	221-153.01	221-153.02
15	Valve disc K	1.4404	221-124.01	221-124.02	221-124.10	221-124.04
16	Double-disk K	1.4404	221-125.01	221-125.02	221-125.10	221-125.04
18	Compression spring	1.4310	931-208	931-001	931-001	931-249
21	Guide ring	Turcite	935-022	935-022	935-022	935-010
22*	O-ring	EPDM	930-268	930-268	930-268	930-243
		FKM	930-164	930-164	930-164	930-244
		HNBR	930-639	930-639	930-639	930-640
25*	O-ring	EPDM	930-311	930-311	930-311	930-276
		FKM	930-335	930-335	930-335	930-277
		HNBR	930-803	930-803	930-803	930-627
29*	O-ring	NBR	930-026	930-026	930-026	930-026
30*	O-ring	NBR	930-026	930-026	930-026	930-026
34	Seat ring	1.4404	221-108.01	221-108.02	221-108.02	221-108.03
35	Blanking plate	1.4404	221-144.01	221-144.02	221-144.02	221-144.03
37	Leakage pipe 90°	1.4301	221-154.07	221-154.07	221-154.07	221-154.07
	Leakage pipe straight	1.4301	221-154.03	221-154.03	221-154.03	221-154.03
38	Hexagon nut	1.4301	709-014	709-014	709-014	709-014

Spare parts list - mixproof valve K

Item	Designation	Material	1"OD	1.5"OD	2" OD	2.5" OD
43	Clamp join KL	1.4401	221-507.02	221-507.04	221-507.04	221-507.09
46	Clamp join KL	1.4401	221-507.06	221-507.06	221-507.06	221-507.06
401	Housing V1	1.4404	221-101.27	221-101.28	221-101.29	221-101.30
402	Housing V2	1.4404	221-102.52	221-102.53	221-102.54	221-102.55
403	Housing KL	1.4404	221-438.07	221-438.08	221-438.09	221-438.10
404	Housing KT	1.4404	221-439.07	221-439.08	221-439.09	221-439.10
420	Housing connection	1.4404	221-571.01	221-571.03	221-571.05	221-571.08
A	Actuator VARIVENT®	See spare parts list/dimensions sheet for VARIVENT® actuator				
B	Control top T.VIS®	See parts list for control top T.VIS®				
Grease RIVOLTA F.L.G. 100g tube not included with seal set. ** Do not grease item 7 and 8 1) The seal set contains items 1, 5, 6, 7, 8, 22, 25, 29 and 30					413-136	

Item	Designation	Material	3" OD	4" OD	6" OD
Seal set complete 1)		EPDM	221-304.14	221-304.15	221-304.17
		FKM	221-519.34	221-519.35	221-519.37
		HNBR	221-519.77	221-004176	--
1*	Seal ring	EPDM	924-085	924-085	924-088
		FKM	924-083	924-083	924-087
		HNBR	924-313	924-313	--
2	Bearing	PTFE/carbon	935-002	935-002	935-003
3	Seal disk	1.4404	221-141.03	221-141.04	221-141.05
4	Bearing disc	1.4301	221-142.03	221-142.03	221-142.04
5*	O-ring	EPDM	930-150	930-156	930-260
		FKM	930-176	930-178	930-259
		HNBR	930-634	930-863	--
6*	O-ring	NBR	930-004	930-004	930-007
**7*	V-ring AX	EPDM	932-024	932-028	932-042
		FKM	932-035	932-039	932-041
		HNBR	932-090	932-100	--
**8*	V-ring AX	EPDM	932-023	932-027	932-045
		FKM	932-034	932-038	932-044
		HNBR	932-089	932-099	--
9	Lantern	1.4301	221-121.08	221-121.09	221-121.22
13	Spring plate K	1.4301	221-155.04	221-155.04	221-155.02
14	Leakage outlet	1.4301	221-153.02	221-153.02	221-153.03
15	Valve disc K	1.4404	221-124.05	221-124.06	221-124.08
16	Double-disk K	1.4404	221-125.05	221-125.06	221-125.08
18	Compression spring	1.4310	931-249	931-002	931-093
21	Guide ring	Turcite	935-010	935-010	935-018
22*	O-ring	EPDM	930-243	930-243	930-356
		FKM	930-244	930-244	930-357
		HNBR	930-640	930-640	--
25*	O-ring	EPDM	930-276	930-276	930-270
		FKM	930-277	930-277	930-163
		HNBR	930-627	930-627	930-637
29*	O-ring	NBR	930-026	930-026	930-035
30*	O-ring	NBR	930-026	930-026	930-026
34	Seat ring	1.4404	221-108.03	221-108.04	221-108.05
35	Blanking plate	1.4404	221-144.03	221-144.04	221-144.05
37	Leakage pipe 90°	1.4301	221-154.07	221-154.07	221-154.09
	Leakage pipe straight	1.4301	221-154.03	221-154.03	221-154.06
38	Hexagon nut	1.4301	709-014	709-014	709-013

Spare parts list - mixproof valve K

Item	Designation	Material	3" OD	4" OD	6" OD
43	Clamp join KL	1.4401	221-507.09	221-507.11	221-507.14
46	Clamp join KL	1.4401	221-507.06	221-507.06	221-507.11
401	Housing V1	1.4404	221-101.31	221-101.32	221-101.72
402	Housing V2	1.4404	221-102.56	221-102.57	221-102.58
403	Housing KL	1.4404	221-438.11	221-438.12	221-438.25
404	Housing KT	1.4404	221-439.11	221-439.12	224-439.24
420	Housing connection	1.4404	221-571.10	221-571.13	221-571.17
A	Actuator VARIVENT®		See spare parts list/dimensions sheet for VARIVENT® actuator		
B	Control top T.VIS®		See parts list for control top T.VIS®		
Grease RIVOLTA F.L.G. 100g tube not included with seal set. ** Do not grease item 7 and 8 1) The seal set contains items 1, 5, 6, 7, 8, 22, 25, 29 and 30					413-136

Item	Designation	Material	2" IPS	3" IPS	4" IPS	6" IPS
Seal set complete 1)		EPDM	221-304.13	221-304.14	221-304.15	221-304.17
		FKM	221-519.33	221-519.34	221-519.35	221-519.37
		HNBR	221-519.76	221-519.77	221-004176	--
1*	Seal ring	EPDM	924-084	924-085	924-085	924-088
		FKM	924-082	924-083	924-083	924-087
		HNBR	924-311	924-313	924-313	--
2	Bearing	PTFE/carbon	935-001	935-002	935-002	935-003
3	Seal disk	1.4404	221-141.02	221-141.03	221-141.04	221-141.05
4	Bearing disc	1.4301	221-142.02	221-142.03	221-142.03	221-142.04
5*	O-ring	EPDM	930-144	930-150	930-156	930-260
		FKM	930-171	930-176	930-178	930-259
		HNBR	930-633	930-634	930-863	--
6*	O-ring	NBR	930-004	930-004	930-004	930-007
**7*	V-ring	EPDM	932-021	932-024	932-028	932-042
		FKM	932-033	932-035	932-039	932-041
		HNBR	932-088	932-090	932-100	--
**8*	V-ring	EPDM	932-019	932-023	932-027	932-045
		FKM	932-032	932-034	932-038	932-044
		HNBR	932-084	932-089	932-099	--
9	Lantern	1.4301	221-121.12	221-121.10	221-121.11	221-121.05
13	Spring plate K	1.4301	221-155.05	221-155.05	221-155.05	221-155.02
14	Leakage outlet	1.4301	221-153.01	221-153.02	221-153.02	221-153.03
15	Valve disc K	1.4404	221-124.13	221-124.11	221-124.12	221-124.08
16	Double-disk K	1.4404	221-125.13	221-125.11	221-125.12	221-125.08
18	Compression spring	1.4310	931-001	931-249	931-002	931-093
21	Guide ring	Turcite	935-022	935-010	935-010	935-018
22*	O-ring	EPDM	930-268	930-243	930-243	930-356
		FKM	930-164	930-244	930-244	930-257
		HNBR	930-639	930-640	930-640	--
25*	O-ring	EPDM	930-311	930-276	930-276	930-270
		FKM	930-335	930-277	930-277	930-163
		HNBR	930-803	930-627	930-627	--
29*	O-ring	NBR	930-026	930-026	930-026	930-035
30*	O-ring	NBR	930-026	930-026	930-026	930-026
34	Seating ring D	1.4404	221-108.02	221-108.03	221-108.04	221-108.06
35	Blanking plate	1.4404	221-144.02	221-144.03	221-144.04	221-144.05
37	Leakage pipe 90°	1.4301	221-154.07	221-154.07	221-154.07	221-154.09
	Leakage pipe straight	1.4301	221-154.03	221-154.03	221-154.03	221-154.06
38	Hexagon nut	1.4301	709-014	709-014	709-014	709-013

Spare parts list - mixproof valve K

Item	Designation	Material	2" IPS	3" IPS	4" IPS	6" IPS
43	Clamp join KL	1.4401	221-507.04	221-507.03	221-507.11	221-507.14
46	Clamp join KL	1.4401	221-507.06	221-507.09	221-507.06	221-507.11
401	Housing V1	1.4404	221-101.37	221-101.35	221-101.36	221-101.17
402	Housing V2	1.4404	221-102.62	221-102.59	221-102.60	221-102.17
403	Housing KL	1.4404	221-438.13	221-438.14	221-438.15	221-438.16
404	Housing KT	1.4404	221-439.13	221-439.14	221-439.15	221-439.16
420	Housing connection	1.4404	221-571.07	221-571.12	221-571.15	221-571.18
A	Actuator VARIVENT®		See spare parts list/dimensions sheet for VARIVENT® actuator			
B	Control top T.VIS®		See parts list for control top T.VIS®			
Grease RIVOLTA F.L.G. 100g tube not included with seal set. ** Do not grease item 7 and 8 1) The seal set contains items 1, 5, 6, 7, 8, 22, 25, 29 and 30					413-136	

sealing sets for VARIVENT® mixproof valve K									
Item	Qty.	Designation	Material	DN 25 1"	DN 40/50 1.5"/2"	DN 65/80 2.5"/3"	DN 100 4"	DN 125	DN 150 6"
1	2	Seal ring	Ø	22	22	28	28	35	35
			EPDM	924-084	924-084	924-085	924-085	924-088	924-088
			FKM	924-082	924-082	924-083	924-083	924-087	924-087
			HNBR	924-311	924-311	924-313	924-313	--	--
5	4	O-ring	Ø	42 x 3	60 x 3	85 x 4	113 x 4	138 x 4	158 x 5
			EPDM	930-309	930-144	930-150	930-156	930-372	930-260
			FKM	930-168	930-171	930-176	930-178	930-409	930-259
			HNBR	930-632	930-633	930-634	930-863	--	--
6	1	O-ring	Ø	8 x 1.6	8 x 1.6	8 x 1.6	8 x 1.6	9 x 3	9 x 3
			NBR	930-004	930-004	930-004	930-004	930-007	930-007
**7	1	V-ring	Ø	35-5	52-6	76-6	104-6	128-6	148-6
			EPDM	932-046	932-021	932-024	932-028	932-060	932-042
			FKM	932-030	932-033	932-035	932-039	932-062	932-041
			HNBR	932-087	932-088	932-090	932-100	--	--
**8	2	V-ring	Ø	28-5	44-6	68-6	96-6	120-6	140-6
			EPDM	932-017	932-019	932-023	932-027	932-059	932-045
			FKM	932-029	932-032	932-034	932-038	932-063	932-044
			HNBR	932-085	932-084	932-089	932-099	--	--
22	1	O-ring	Ø	22 x 3	22 x 3	28 x 3	28 x 3	35 x 3	35 x 3
			EPDM	930-268	930-268	930-243	930-243	930-356	930-356
			FKM	930-164	930-164	930-244	930-244	930-357	930-357
			HNBR	930-639	930-639	930-640	930-640	--	--
25	1	O-ring	Ø	11 x 3	11 x 3	15 x 3	15 x 3	20 x 3	20 x 3
			EPDM	930-311	930-311	930-276	930-276	930-270	930-270
			FKM	930-335	930-335	930-277	930-277	930-163	930-163
			HNBR	930-803	930-803	930-627	930-627	--	--
29	1	O-ring	Ø	20 x 3	20 x 3	20 x 3	20 x 3	25 x 3	25 x 3
			NBR	930-026	930-026	930-026	930-026	930-035	930-035
30	1	O-ring	Ø	20 x 3	20 x 3	20 x 3	20 x 3	20 x 3	20 x 3
			NBR	930-026	930-026	930-026	930-026	930-026	930-026
Seal set complete			EPDM	221-304.12	221-304.13	221-304.14	221-304.15	221-304.16	221-304.17
			FKM	221-519.32	221-519.33	221-519.34	221-519.35	221-519.36	221-519.37
			HNBR	221-519.75	221-519.76	221-519.77	221-004176	--	--
Grease RIVOLTA F.L.G. 100g tube not included with seal set. ** Do not grease item 7 and 8						413-136			

Advice on storage: storage in accordance with DIN 7716

Relative humidity approx. 65%, temperature 15-25°C and protected from light

When replacing seals, observe the instructions in the instruction manual!

429-017

14 Dimension Sheet - VARIVENT® Double Seat Valve K

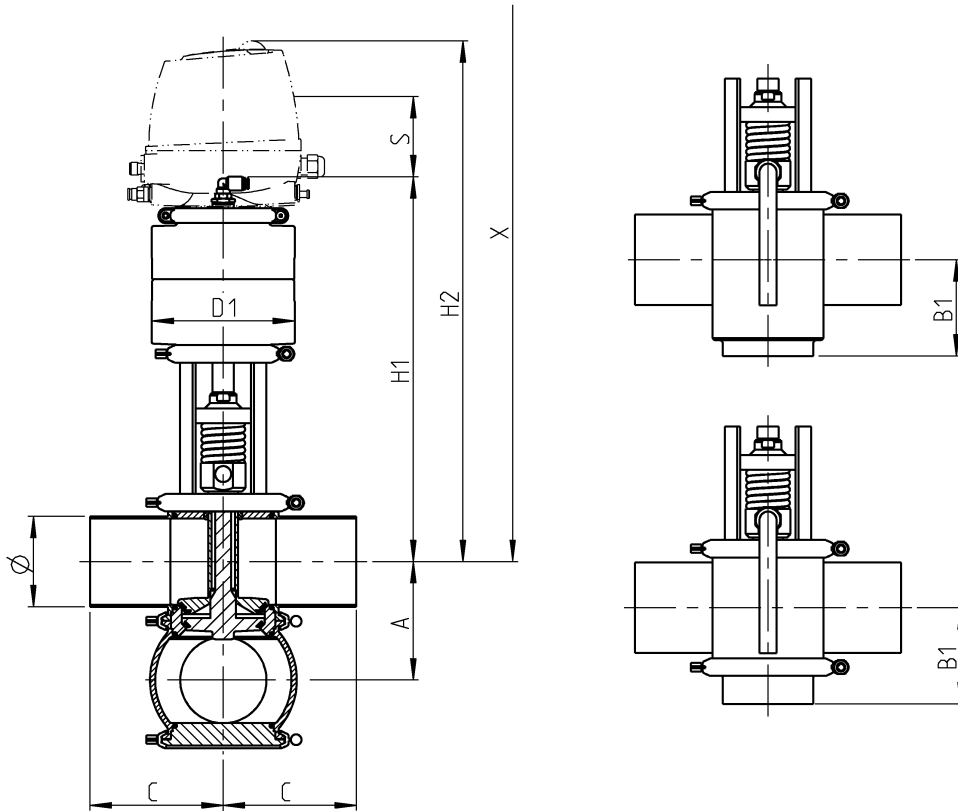

Fig.22

Dimension Sheet - VARIVENT® Double Seat Valve K

Nominal Width	Tube	Housing			Actuator	Dimension			Valve	
	Ø [mm]	A [mm]	B 1 [mm]	C [mm]	D 1 [mm]	H 1 [mm]	H 2 [mm]	Expansion X [mm]	Stroke S [mm]	Weight [kg]
DN 25	29.0 x 1.50	50.0	58.0	90	135	329.0	458.0	563	22	9
DN 40	41.0 x 1.50	62.0	64.0	90	135	338.0	467.0	572	25	11
DN 50	53.0 x 1.50	74.0	70.0	90	135	341.0	470.0	575	30	11
DN 65	70.0 x 2.00	96.0	83.0	125	170	382.0	511.0	686	30	18
DN 80	85.0 x 2.00	111.0	90.5	125	170	399.5	528.5	704	40	18
DN 100	104.0 x 2.00	130.0	100.0	125	170	409.0	538.0	713	40	26
DN 125	129.0 x 2.00	155.0	113.0	150	210	554.5	683.5	914	60	57
DN 150	154.0 x 2.00	180.0	125.0	150	210	661.0	790.0	1020	60	65
OD 1"	25.4 x 1.65	46.0	56.0	90	135	327.0	456.0	561	18	9
OD 1.5"	38.1 x 1.65	59.0	62.5	90	135	336.5	465.0	571	22	11
OD 2"	50.8 x 1.65	71.5	69.0	90	135	343.0	472.0	577	30	11
OD 2.5"	63.5 x 1.65	90.0	80.0	125	170	386.0	515.0	690	30	17
OD 3"	76.2 x 1.65	103.0	86.5	125	170	402.5	531.5	707	39	18
OD 4"	101.6 x 2.11	127.5	99.0	125	170	411.0	540.0	715	40	26
OD 6"	152.4 x 2.77	177.0	123.5	150	210	659.5	788.5	1090	60	66
IPS 2"	60.3 x 2.00	81.0	73.5	114.3	135	344.5	473.5	579	29	12
IPS 3"	88.9 x 2.30	115.0	92.5	152.5	170	401.5	530.5	706	40	19
IPS 4"	114.3 x 2.30	140.0	105.0	152.5	170	414.0	543.0	718	40	27
IPS 6"	168.2 x 2.77	192.0	131.0	152.5	210	655.0	784.0	1014	60	67

Please note that for this type of valve, there should be a clearance of 10 - 100 mm beneath the leakage outlet.

15 Appendix

15.1 Lists

15.1.1 Abbreviations and terms

Abbreviation	Explanation
BS	British Standard
bar	Unit of measurement of pressure [bar] All pressure data expressed in [bar/psi] is assumed to be gauge pressure [barg/psig] unless explicitly specified otherwise.
approx.	approximately
°C	Unit of measurement of temperature [degree Celsius]
dm ³ _n	Unit of measurement of volume [cubic decimetre] Standard volume (standard litre)
DN	DIN nominal width
DIN	German standard issued by DIN (Deutsches Institut für Normung e.V., German Institute for Standardization)
EN	European Standard
EPDM	Material designation Short designation according to DIN/ISO 1629: Ethylene Propylene Diene Rubber
°F	Unit of measurement of temperature [degree Fahrenheit]
FKM	Material designation, short designation according to DIN/ISO 1629: Fluorine rubber
h	Unit of measurement of time [hour]
HNBR	Material designation Short designation according to DIN/ISO 1629: Hydrogenated Acrylonitrile Butadiene Rubber
IP	Protection class
ISO	International standard issued by the International Organisation for Standardisation
kg	Unit of measurement of weight [kilogram]
kN	Unit of measurement of force [kilonewton]
Kv value	Flow coefficient [m ³ /s] 1 KV = 0,86 x Cv
l	Unit of measurement of volume [litre]
max.	maximum
mm	Unit of measurement of length [millimetre]
µm	Unit of measurement of length [micrometre]

Abbreviation	Explanation
M	Metric
Nm	Unit of measurement of work [newton metre] Specification of torque 1 Nm = 0.737 lbft Pound-Force (lb) + Feet (ft)
PA	Polyamide
PE-LD	Low-density polyethylene
PPE	Polytetrafluoroethylene
psi	America measurement for pressure [Pound-force per square inch] All pressure data expressed in [bar/psi] is assumed to be gauge pressure [barg/psig] unless explicitly specified otherwise.
PTFE	Polytetrafluoroethylene
SET-UP	Self-learning installation During commissioning and maintenance, the SET-UP procedure carries out all the necessary settings for the generation of messages.
AF	Specifications for the size of spanners width across flats
T.VIS	Tuchenhagen Valve Information System
V AC	Volt alternating current
V DC	Volt direct current
W	Unit of measurement of power [Watt]
TIG	Welding method Tungsten inert gas welding
Inch	Unit of measurement of length in the Anglo-American language area
Inch OD	Pipe measurement according to British Standards (BS), Outside Diameter
Inch IPS	American pipe measure - Iron Pipe Size



We live our values.

Excellence · Passion · Integrity · Responsibility · GEA-versity

GEA Group is a global engineering company with multi-billion euro sales and operations in more than 50 countries. Founded in 1881, the company is one of the largest providers of innovative equipment and process technology. GEA Group is listed in the STOXX® Europe 600 Index.

GEA Germany

GEA Tuchenhausen GmbH
Am Industriepark 2-10
21514 Büchen, Germany

Tel +49 (0)4155 49 0
Fax +49 (0)4155 49 2035

gea.com/contact