



# GEA DIRECT SPRAYER DS 25

Technical brochure  
Retractable Cleaner

# DIRECT IMPACT CLEANING SAVES TIME AND MONEY

## Overcoming spray shadow challenges to ensure thorough cleaning of vessels with internal components.

Cleaning vessels with internals can often present a challenge, as these components tend to create shadow areas that are difficult to reach from cleaners installed in the top. However, this issue is effectively addressed with the GEA Direct Sprayer DS 25. Designed for permanent installation into the bottom and sides of vessels, the GEA Direct Sprayer DS 25 ensures consistent and reliable cleaning performance.

The GEA Direct Sprayer DS 25 combined with top-mounted cleaners, enables the complete cleaning of vessels by eliminating the hidden cleaning areas created by agitators, baffles, and other internals such as heating and cooling coils. This combination ensures that no part of the vessel is left uncleaned, even those typically obstructed by internal components.



### General Specifications / Technical Data\*

Spray distance	max. 5 m
Spray pattern	full cone spray
Flow rate	3.9–8.8 m <sup>3</sup> /h 65–147 l/min 17–39 US gpm
Operating pressure CIP	2–10 bar / 29–145 psi
Control air pressure	6–8 bar / 87–116 psi
Weight	2.7–5.1 kg
Temperature CIP	max. 135 °C / 275 °F
Ambient temperature	max. 80 °C / 176 °F

\* Data depending on configuration

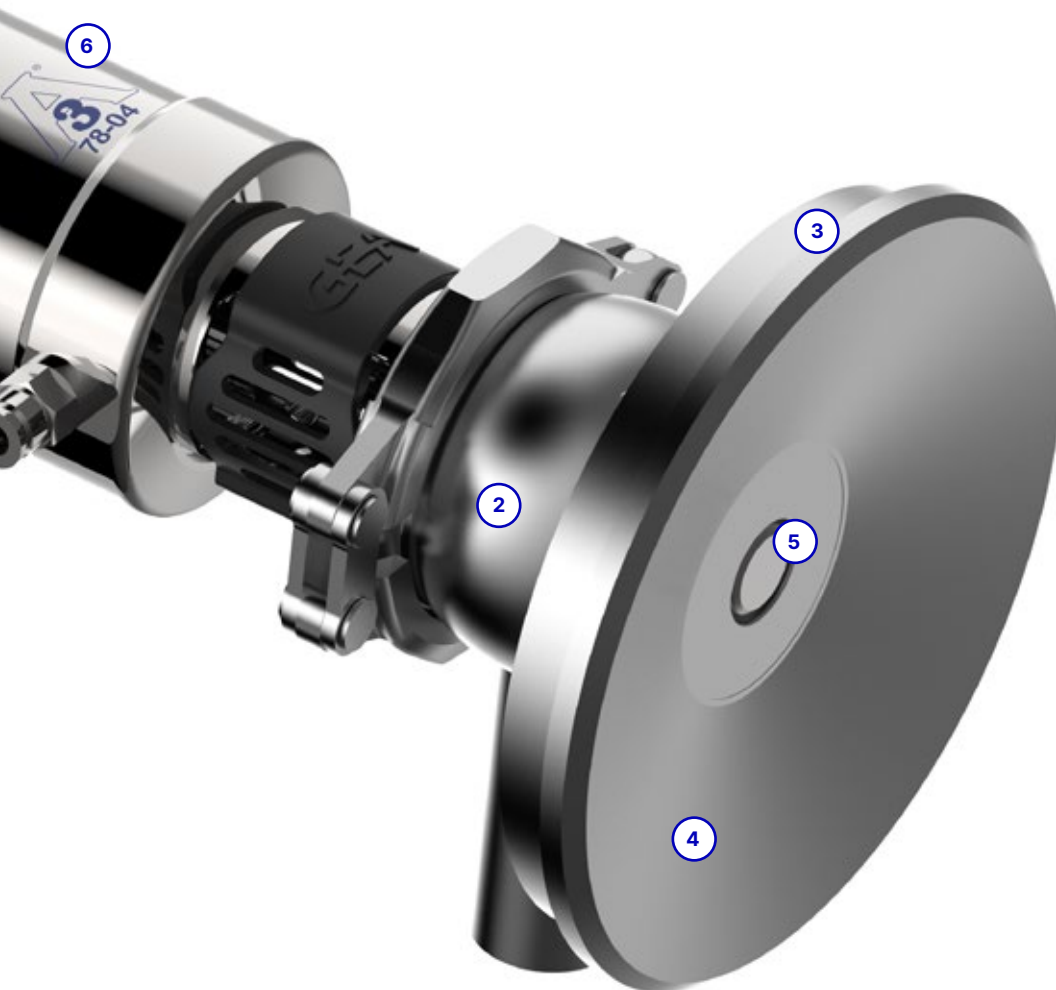

#### **1 Feedback system**

Three different feedback systems to choose between manual or automatic handling.

#### **2 Housing**

Possible to choose from different standard sizes and connection types to meet the requirements of different markets and applications.

#### **3 Tank connection**

Multiple types are available for welding in various positions on the vessel, irrespective of inclinations or curvature.

#### **4 Material and surface finish**

Parts in contact with the product can be made from different materials and surface grades to fulfill all requirements, including those for more delicate processes.

#### **5 Nozzle**

Unique nozzle design that opens into the cleaner body, ensuring no protrusion into the tank and producing a powerful full cone spray. Combined with well-designed seals, it maintains the highest process integrity when closed.

#### **6 Compliance**

3A certified version available – ensuring compliance with the highest hygienic standards and supporting safe and reliable operation in all areas of use.

# Performance data

## Revolutionizing vessel cleaning with the high-performance GEA Direct Sprayer DS 25

When activated, the GEA Direct Sprayer DS 25 generates a powerful spray which effectively cleans those hard-to-reach areas, ensuring thorough coverage and cleaning performance. With the GEA Direct Sprayer DS 25, you achieve complete cleaning at a fraction of the traditional cleaning costs, providing a more efficient and cost-effective solution for vessel maintenance.

Its unique design produces a highly turbulent full cone spray, which delivers exceptional cleaning efficiency and coverage. The powerful spray ensures thorough cleaning even in large vessels. With a spray force of up to 5.0 kg, the GEA Direct Sprayer DS 25 provides high-impact cleaning, making it a robust solution for overcoming the challenges of cleaning vessels with internals.

## Flow performance data

The diagram shows the flow rate at different operating pressures.

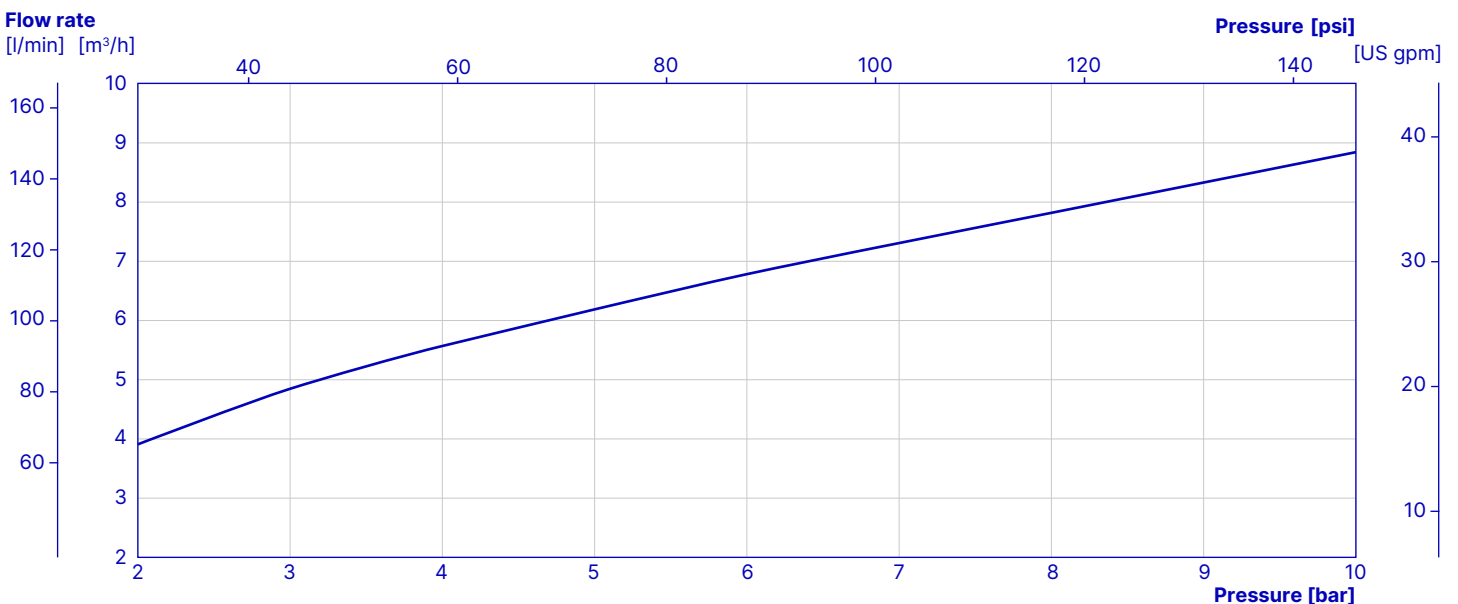

# Spray performance data

The GEA Direct Sprayer DS 25 is designed for flexible installation in any conceivable position. The graphs illustrate the spray performance data for three of the most common installation positions and include the following key aspects:

- **Impact intensity** is represented by the different shades of blue. The darker blue regions highlight the high-impact areas, where the cleaning force is strongest.

- **Width** shows how the spray pattern expands from the center of the cleaner.
- **Distance and height** shows the effective spray distance the cleaner can reach.
- **Recommended pressure** gives guidance on the optimal pressure ranges needed to ensure that the GEA Direct Sprayer DS 25 delivers optimal cleaning results.

## Horizontal →

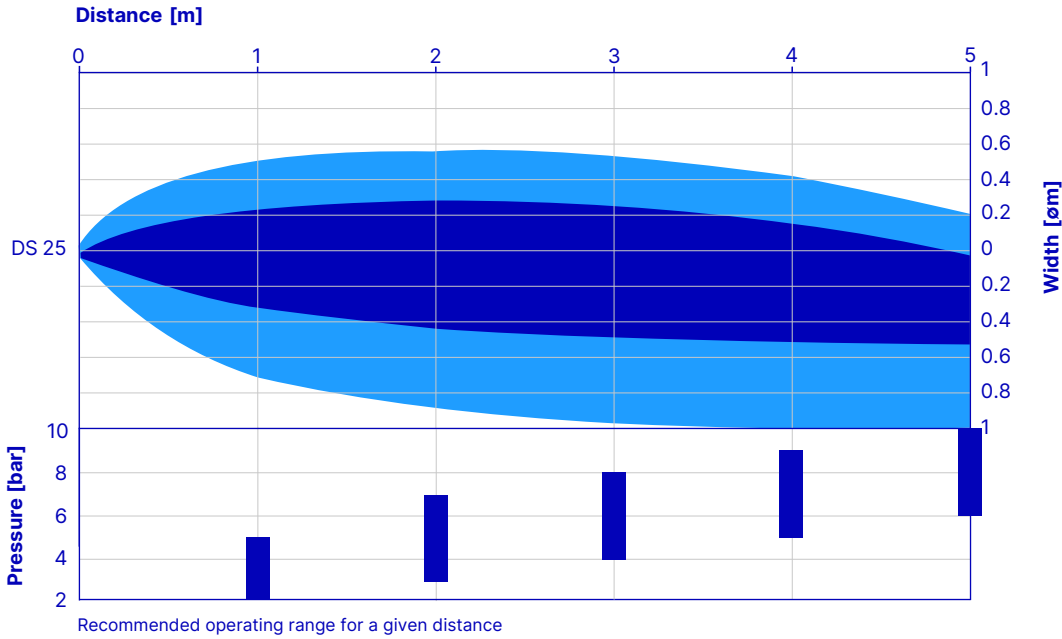

## 45 Degrees upward ↗

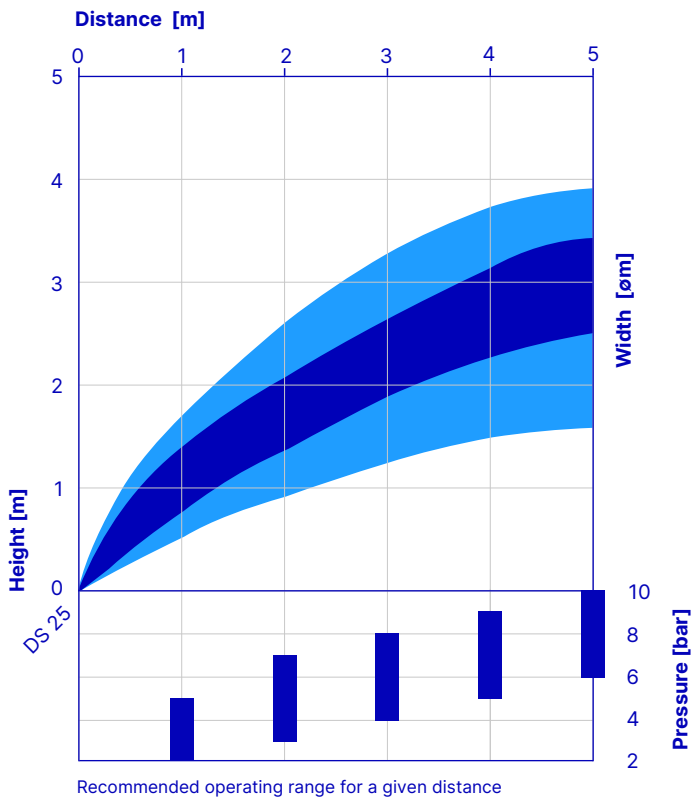

## Vertically up ↑

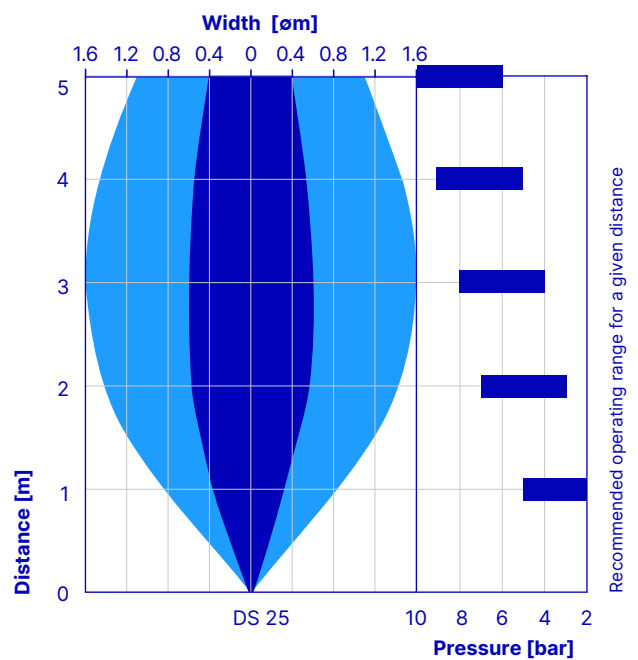

All diagrams are based on a cleaning medium of: density 1 kg/dm<sup>3</sup>, viscosity 1 mm<sup>2</sup>/s, temperature 20 °C

# Dimensions

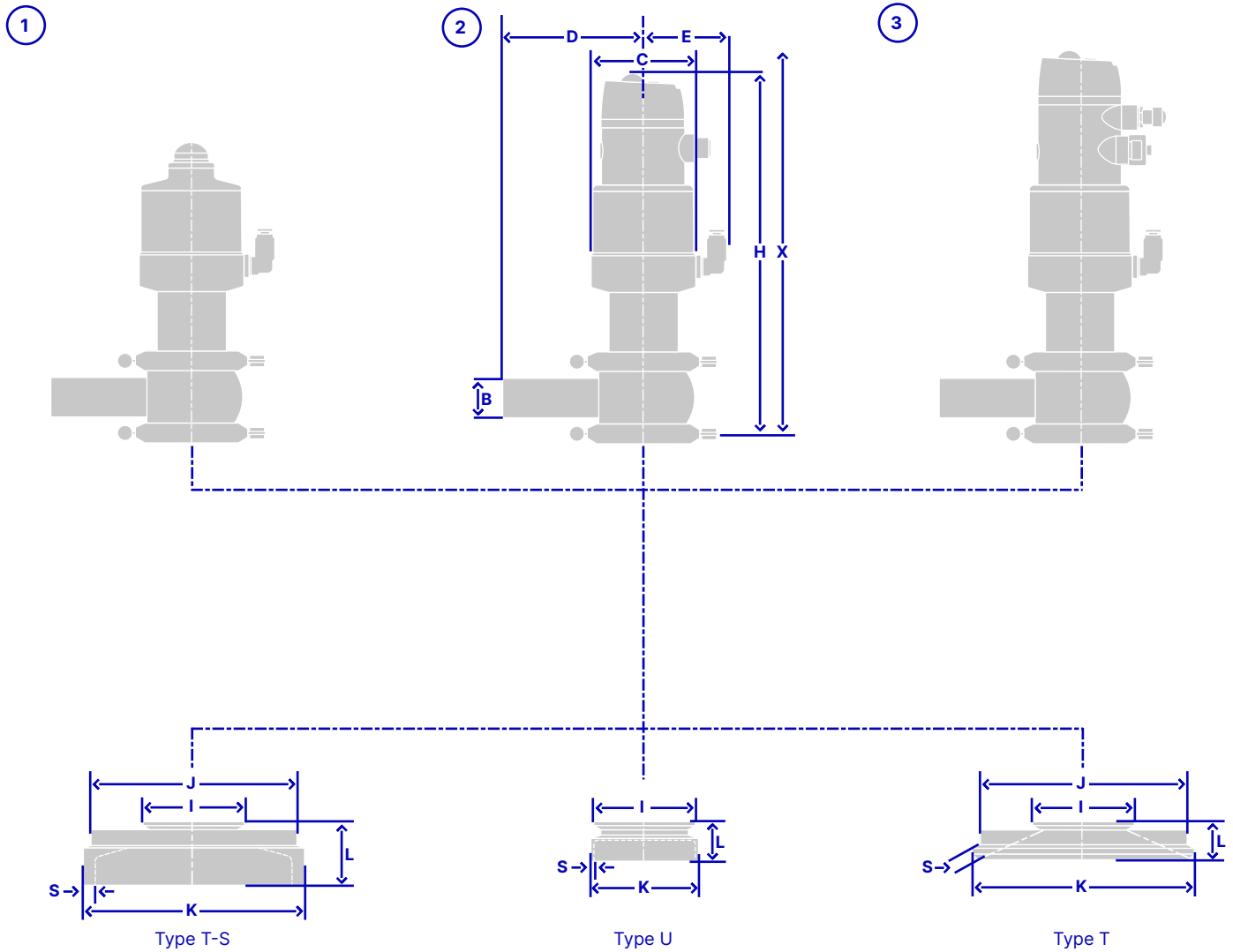

## Dimensions GEA Direct Sprayer DS 25

Nr.	Feedback system	Nominal size housing	B [mm]	C [mm]	D [mm]	E [mm]	H* [mm]	X** [mm]
1	Visual Monitoring	DN25	Ø 29	Ø 69	90	55	194	257
		1" OD	Ø 25.4				190	249
2	T.VIS® V1 Position Indicator	DN25	Ø 29	Ø 69	90	55	240	303
		1" OD	Ø 25.4				236	295
3	T.VIS® V1 Control Head	DN25	Ø 29	Ø 69	90	57	256	319
		1" OD	Ø 25.4				252	311

\* Height – always measured from the top of the tank connection

\*\* Space required for maintenance – always measured from the top of the tank connection

## Dimensions Tank Connections

Type	I [mm]	J [mm]	K [mm]	L [mm]	S [mm]
T	Ø 66	Ø 135	Ø 145	24	max. 8
T-S	Ø 66	Ø 135	Ø 145	41	max. 8
U	Ø 66	–	Ø 70	25	2

# Selection Support

## Version

The Hygienic version offers reliable performance and meets all common hygiene standards for a wide range of uses. The Hygienic 3A version provides certified compliance with 3A standards – delivering maximum safety, hygiene, and confidence wherever officially approved components are required.



## Tank connection

The tank connections are welded into the vessel wall or bottom. Please refer to the tables below for the minimum tank diameter required for each type.

### Minimum tank diameter

Type	Wall thickness tank [mm]							
	2	3	4	5	6	7	8	
T	950	1,150	1,450	1,950	3,050	3,050*	3,050*	
T-S	290	300	310	320	330	350	370	
U	500	500	500	–	–	–	–	

\* 0.5 – 1 mm overhang at critical weld area

## Parts in contact with product and CIP medium

Product contacted means all parts in touch with the product processed in the vessel. Such parts are marked green in the picture.

CIP medium contacted means all parts in touch with the CIP medium and the product processed in the vessel. Such parts are marked blue and green in the picture.

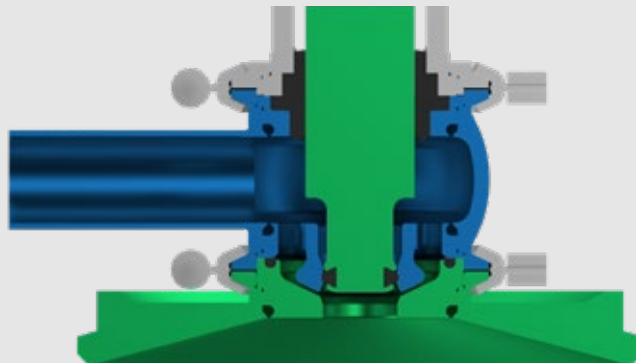

# Order Information

Position	Description of the order code for the standard version
<b>1</b>	<b>Cleaner designation</b>
	DS25 Direct Sprayer DS 25
<b>2</b>	<b>Version</b>
	H Hygienic version
	H-3A Hygienic 3A version
<b>3</b>	<b>Nozzle</b>
	1 Type 1
<b>4</b>	<b>Norm of size</b>
	DN
	OD
<b>5</b>	<b>Size</b>
	25
	1"
<b>6</b>	<b>Housing combination</b>
	L 1 socket
	T 2 sockets
<b>7</b>	<b>Pressure connection</b>
	0 Welding socket
	TN VARIVENT® groove flange incl. O-ring and connecting parts
	TK VARIVENT® flange connection, groove flange on housing
	AVK Hygienic screwed union, DIN 11864-1, DIN 11853-2
	AVN Aseptic screwed union, DIN 11864-1
	ASK Hygienic flange connection, DIN 11864-2, DIN 11853-2
	ASN Aseptic flange connection, DIN 11864-2
	NFK Hygienic grooved flange, DIN 11864-2, DIN 11853-2
	CO Clamp connection, DIN 32676 (DN) / ISO 2852
<b>8</b>	<b>Tank connection</b>
	T Connection type T
	TS Connection type T-S
	U Connection type U
<b>9</b>	<b>Size of tank connection</b>
	DN25
<b>10</b>	<b>Gasket material</b>
	1 EPDM
	2 FKM

Position	Description of the order code for the standard version
<b>11</b>	<b>Material CIP medium contacted</b>
	2 1.4404
<b>12</b>	<b>Surface CIP medium contacted</b>
	10 R <sub>a</sub> 0.8 µm
	11 R <sub>a</sub> 0.4 µm electropolished
<b>13</b>	<b>Surface finish housing outside</b>
	M Outside matt
	G Outside ground
	E Outside ground and electropolished
<b>14</b>	<b>Material product contacted</b>
	12 1.4404/316L
	9 2.4602
<b>15</b>	<b>Surface product contacted</b>
	10 R <sub>a</sub> 0.8 µm
	11 R <sub>a</sub> 0.4 µm electropolished
<b>16</b>	<b>Cap material</b>
	P Plastic PPS
<b>17</b>	<b>Certificates</b>
	0 Without certificate
	W Factory certificate EN10204 – 2.2
	Z Material certificate EN10204 – 3.1
	K FDA DoC
	E Regulation (EU) No. 1935/2004, No. 2023/2006, No. 10/2011 DoC
	A ADI free DoC
	U USP class VI DoC
	O Surface finish test & protocol product contacted
<b>18</b>	<b>Ex-protected</b>
	K No explosion area
<b>19</b>	<b>Identification label</b>
	52 Adhesive label
<b>+</b>	
<b>20</b>	<b>Location of feedback</b>
	000 Visual monitoring
	T Control module T.VIS® V1

The code is composed as follows depending on the chosen configuration:

Position	1	2	3	4	5	6	7*	8	9	10	11	12	13	14	15	16	17	18	19	20				
Code	DS 25	-	-	1	-	-	-	-	-	DN 25	-	-	2	-	-	-	-	P	/	/	K	/	52	+

\* If the housing combination T is chosen, a connection fitting can be selected for each of the two sockets.

# Order Information

If "location of feedback" has been selected with "000 – Visual monitoring" the order code will continue with the following:

Position	Description of the order code for the standard version	
<b>21</b>	<b>Feedback</b>	
	0	0 digital feedbacks
<b>22</b>	<b>Air connection</b>	
	M	Air hose Ø 6/4 mm
	Z	Air hose Ø 6,35/4,31 mm (¼")

The code is composed as follows depending on the chosen configuration:

<b>Position</b>	<b>21</b>	<b>22</b>
Code	0	

If "location of feedback" has been selected with "T – Control Module T.VIS® V1" the order code will continue with the following:

Position	Description of the order code for the standard version	
<b>21</b>	<b>T.VIS® version</b>	
	V1	T.VIS® V1 Position indicator
	V1	T.VIS® V1 Control top
<b>22</b>	<b>Control top type</b>	
	N	Type N (no solenoid valve)
	P	Type P (1 solenoid valve)
<b>23</b>	<b>Feedback</b>	
	2	2 digital feedbacks
<b>24</b>	<b>Type of interface</b>	
	A	AS-Interface bus
	B	24V DC, 3 Wire PNP
	D	Device Net
<b>25</b>	<b>Screw connection</b>	
	D	5-pin connector M12 6/4 mm
	K	5-pin connector M12 1/4" OD
<b>26</b>	<b>Connection box</b>	
	81	ASI-connection box 1 m cable
	82	ASI-connection box 2 m cable
	22	With connection box(es)
	O	Without connection box
<b>27</b>	<b>Protection class</b>	
	65	IP65 Splash water (EN 60529)
	67	IP67 Immersion (EN 60529)

The code is composed as follows depending on the chosen configuration:

<b>Position</b>	<b>21</b>	<b>22</b>	<b>23</b>	<b>24</b>	<b>25</b>	<b>26</b>	<b>27</b>
Code	V1		2		/	/	

# Feedback System



The **visual monitoring**, also known as mechanical position indicator, is a simple visual feedback unit of the cleaner that allows the operator to check the status manually. It is especially useful when no automatic feedback and control system is required. The pneumatic actuation of the cleaner is realized by an external solenoid valve, e.g. via a solenoid valve battery of the customer.



The **T.VIS® V-1 position indicator** is an automatic position detection system that uses colored LEDs to provide clear visual feedback on the status of the cleaner. In addition, the operating status will be provided as digital feedback via common communication types. The pneumatic actuation of the cleaner is realized by an external solenoid valve, e.g. via a solenoid valve battery of the customer.



The programmable **T.VIS® V-1 control top** is an extension of the T.VIS® V-1 position indicator and is equipped with an additional solenoid valve for automated actuation of the cleaner. In addition to the colored status LEDs and digital feedback, this version enables the cleaner to be controlled by the higher-level control system via the same common communication types.

**GEA Tuchenhagen GmbH**  
Am Industriepark 2-10  
21514 Büchen, Germany

[gea.com/flowcomponents](https://gea.com/flowcomponents)  
[flowcomponents@gea.com](mailto:flowcomponents@gea.com)