

# BETTER WORLD. BETTER PRODUCTS.

Sustainability brings enormous benefits – for the planet, for the people, and for your future-proof business development. Discover our breakthrough product solutions.

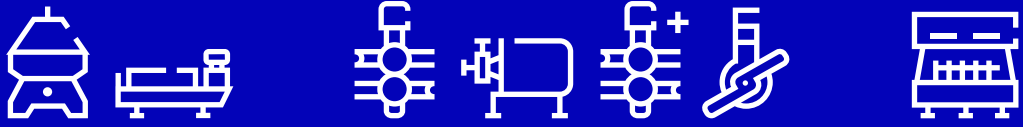

# CONTENTS

Better World	3	GEA Flow Components	20
GEA Ecolabel	6	GEA Homogenizer	32
Better Products	7	GEA Digitalization	38
GEA Separation	8	Act Now	40

# A better world is only a thought away.

It's time to act. The solutions for a sustainable and climate-friendly economy are already here – or at least they are when you take a look at the GEA product portfolio.

Pressures are rising in all industry segments; the global challenges of exploding energy costs, water shortages, and the availability of resources make a faster transformation to smarter solutions absolutely essential.

## **Sustainability is in our DNA**

Making our customers' production processes more efficient has always been the driving force behind our key objective – the maximization of yield and significant savings in terms of energy and resources. Today, this is more relevant than ever before. And the sustainability goals that GEA sets itself today are far more ambitious than the regulatory standards and statutory requirements around the world.

But what does this mean for our partners who rely on our machines and solutions to keep their businesses running? On the one hand, it's the ability to realize enormous savings potential by fine-tuning many points in the process chain. On the other hand, it's certainty of owning a future-proof machine pool as our solutions evolve to fulfill all future demands and stay ahead of new developments in the fields of digitalization and data gathering.

"Engineering for a better world" – this describes not only our corporate purpose but also the concrete product benefits that pay dividends for your business throughout the production process.





## We never rest in our efforts to do and make everything better.

Sustainability inspires our daily entrepreneurial activities and is the first pillar of our corporate strategy. We lead the field to enable the industry to move forward – to safeguard the corporate business sector, achieve our own sustainability goals, and protect the livelihoods of future generations.

In 2021, GEA implemented Mission 26 to leverage the acceleration of a sustainable and profitable growth strategy. In addition to sustainability, this includes the areas of innovation, digital solutions, new food, selective acquisitions, and excellence initiatives in the areas of sales, service, and operations.

## Measurable interim targets by 2030 include, among others:

- **18%** reduction of greenhouse gas emissions throughout the entire product-relevant value chain (against 2019)
- **100%** of the new machines delivered have the zero freshwater use option
- **100%** of packaging materials for machines and service parts in line with the five Rs of a sustainable circular economy: Reduce, Reuse, Repair, Remanufacture, Recycle



# Focusing on a better world.

From energy to water – solutions-oriented in four sustainability sectors.

Anyone who believes in a better world cannot ignore the parameters of energy, water and lubricant consumption as well as circular economies in process systems – each of which requires its own problem-solving expertise in order to maximize savings and conservation of resources.

“Setting the focus on sustainability pays for itself. This is because it creates a win-win situation for customers and partners who invest in innovative machines and solutions from GEA. One of the wins is the uncompromising pursuit of a sustainability strategy. Actual savings in terms of resources are another win that leads to monetary benefits – investments very quickly pay for themselves.”

Klaus Stojentin,  
CEO Separation & Flow Technologies Division



# Become future-proof with the Add Better ecolabel.

Get an idea of what the sustainability pipeline of the near future looks like. The Add Better label is our overall holistic approach to signal greener times ahead in specific cases.



## Our Green Label process step by step

In order to systematically generate awareness for our “Better Product” branding, GEA rolled out the Add Better ecolabel for a variety of solutions. The cornerstones for qualification are:



### 1. Recognized proof of performance

GEA's Add Better label process meets ISO requirements for self-declared environmental claims, ensuring sustainable solutions that are more resource-efficient than their predecessors.



### 2. Meaningful documentation protocol

GEA defines the technical, geographical, and temporal scope of the solution and its assessment. On this basis, relevant data about the technology and its predecessor is collected and verified.



### 3. Independent verification

A high level of certainty and authenticity is achieved through validation by TÜV, a global leader in independent testing, inspection, and certification services.

## Add Better helps to reduce greenhouse gas emissions

Every day, our purpose “Engineering for a better world” drives us to develop solutions that use less energy, water, and raw materials and produce less waste. The Add Better label identifies the most significant advances we are making in this area.

# With the help of better products in many use cases.

Product solutions for a better world from three market-dominating business units. Innovative solutions from GEA as potential game-changers in process chains belong in every strategy for sustainable value creation and business success. And here, we think outside the box in each respective product category.

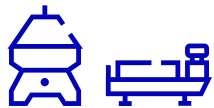

## Leveraging improvement with GEA Separation

Our state-of-the-art separators and decanter centrifuges efficiently process liquids and liquid mixes. This enables the realization of savings potential across all industry segments – for instance, chemicals, beverages, marine, dairy products, food, oil and gas, pharmaceuticals, and environmental technology.

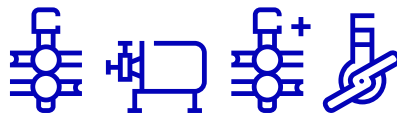

## More sustainability with GEA Flow Components

Our components ensure that your production runs smoothly and make it possible to achieve considerable water and energy savings. The product portfolio includes high-quality modular components in four categories: hygienic and aseptic valves, hygienic pumps, and cleaners for a variety of different industries.



## Higher efficiency with GEA Homogenizer

In processes where homogenizers are involved, micronization of liquid particles is a key step to achieve time-stable products, homogeneous emulsions, and effective cell rupture. Homogenizing valves are therefore an important aspect to optimize the efficiency of homogenizers, but there are many options and peripheral devices that can complete the configuration of the machine in terms of sustainability.

Better products from our three business units reduce your carbon footprint and your energy and water consumption.



LESS IS  
MUCH MORE.  
LET'S TALK  
ABOUT SAVINGS.

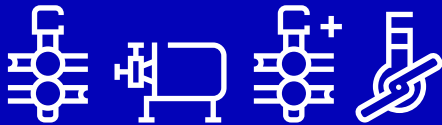
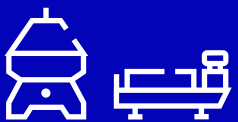



# Thinking big for lakes and rivers as well as for future generations.

GEA environmental Decanters play a decisive role in the treatment of water and sewage around the globe – with innovative, highly efficient, and, in some cases, even mobile solutions.

We demonstrate that it is possible to conserve valuable resources, use them sustainably, and find answers to the challenges of our time, such as water shortages, population growth, and urbanization.

Every day, we strive to ensure that our children will inherit a world that is sustainable and offers them the quality of life they deserve, and that we can actively contribute to shaping a better future for all.

## Water-rich and determined:

There are 183 lakes around Bengaluru – the capital of India's southern state of Karnataka, India's Silicon Valley. Planning foresees the rapid improvement of many things in this large region – with GEA as a technology partner and advisor.



# A fast-growing case with 55 decanters in India.

A total of 95 of the 183 lakes in the 1,400 km<sup>2</sup> region around the modern city of Bengaluru have already been revitalized. These are important for wildlife, leisure activities, and religious rituals on and by the waters, and for the protection of freshwater supplies.

India still discharges 40 billion liters of untreated sewage sludge into water sources every day and only 30% of wastewater is treated. Bengaluru is changing the statistics in partnership with GEA.

## **Sewage treatment plants augmented by GEA decanters**

In the meantime, 33 sewage treatment plants with a daily throughput capacity of more than 1,370 million liters have been constructed. Together with three further large-scale plants under construction and 14 smaller sewage treatment plants, each with the capacity for treating 124 million liters of sewage, the overall capacity will soon top the 1,633-million-liter mark. This does not mark the end of the project – the 95 lakes so far are only the beginning.

## **Local GEA production facility in Bengaluru**

GEA decanter centrifuges are manufactured locally in Bengaluru. This supports the government initiatives for the rejuvenation of lakes and other water bodies. Our experts in the region are always on hand to support installation, commissioning, and day-to-day operation.

**“Thanks to GEA decanters, we are able to reclaim precious water from the wastewater sludge.”**

V.S. Narayanan,  
Environmental Project Manager  
& Consultant



## Rethinking water treatment

The Bengaluru region is a blueprint for numerous other urban agglomerations around the globe – when ...

- water pollution increases
- there are knock-on effects in the region
- immediate remedial action is required
- high capacities are needed
- centrifuge technology can grow with the increasing demands



### The battle against water pollution

The company's purpose "Engineering for a better world" really comes into its own when faced with enormous challenges such as those encountered in Bengaluru: **55 GEA bio-solids Decanters** are currently installed and are reclaiming **almost 1.5 billion liters of water from sewage sludge** per year – a gigantic amount that is enough to fill around **600 Olympic-sized swimming pools**. The coming years should see this figure increase by **a further 1.22 billion liters**.

### Requirements and supply details

- Decanter centrifuges are used for the reclamation of water from sewage sludge produced in the last stage of the sewage treatment process
- The use of them also makes good sense in smaller sewage treatment plants

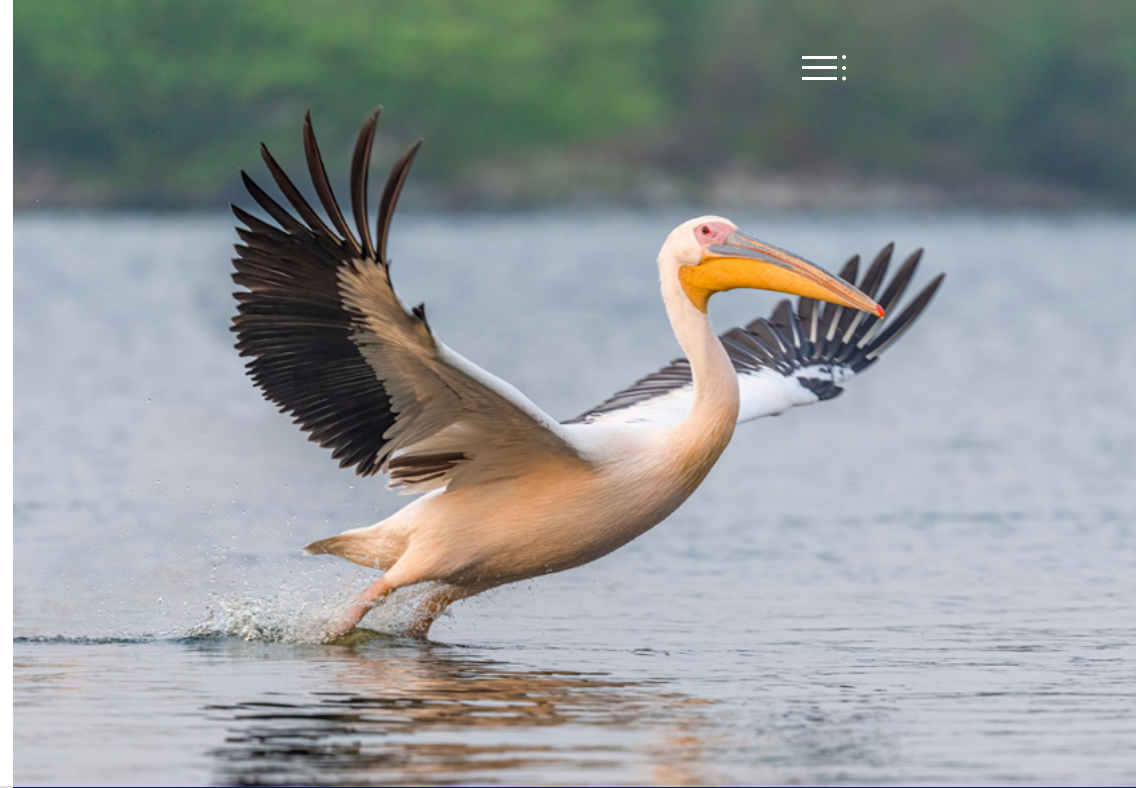

# 95

lakes in the Bengaluru region have been revitalized

with the aid of GEA decanter systems

# A safeguarding case in Indonesia.

GEA provides the key technology for a large-scale drinking water plant in Indonesia – not only to safeguard the supply of potable water for the community, but also to counteract the effects of silting in local rivers and flooding.

Indonesia is making tremendous efforts to improve its water supply infrastructure. In 2013, 80% of the sampling points revealed excessive pollution – but the situation is now much better in many regions.

## **GEA decanter centrifuges take up the fight against sludge**

A comprehensive sludge management system and energy-efficient decanter centrifuges ensure efficient sludge treatment by separating the water from the solids. The result is a significant reduction in sludge volume, which in turn means lower transportation and disposal costs.

## **Investments that generate real income**

Apart from the important health and environmental benefits, the World Bank report also sees potential income from the sewage treatment plants in the form of:

- reclamation of energy, biosolids, and nutrients
- re-usable water



# 90

percent reduction  
of sludge volume

with GEA decanter centrifuges

# Water consumption reduced to the max.

The optimization concept of the GEA Advanced Water Supply is an example of how further savings potential can be unlocked at every point within the process chain. In this case, it is the smart reduction of the consumption of closing and cooling water without any negative effects on performance.

#### Optimized process control to reduce water consumption

With optimized control matched to the technical conditions, it is possible to optimize the consumption of control water for a **self-cleaning centrifuge** as well as the cooling water for the **direct drive, the hood, and the solids catcher**.



#### Temperature-dependent cooling water control

Cooling water supply based on actual workload and cooling demand.



**Optimization of closing water timers based on actual process requirements**

How does it work?

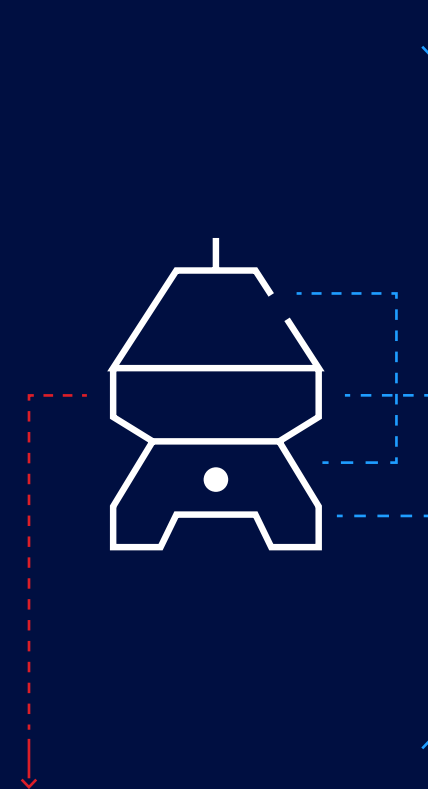

Savings potential for closing water of up to

# 75

percent depending on machine type



# 48

percent reduction of water consumption

with GEA skimming separator MSI 230



### An impressive skimming separator case

What the responsible handling of water as an essential resource can look like in the real world, is clearly demonstrated by a use case with the GEA MSI 230 cream skimming separator: assuming **8,000 operating hours a year**, a **cooling water temperature of 20°C**, and no GEA Centrifuge Water Saving Unit installed, the Advanced Water Supply effect achieves water savings of **48%**, which translates to a total of **716,000 liters per year**.



# 716,000

liters of water saved

A big sustainable gain



# Efficiency in every aspect of the process.



The GEA CIPClean Separator closes a gap in the consistently efficient and sustainable process management chain. This is because the clarifier mounted on an easy-to-connect skid lowers the consumption of water, energy, and CIP media and, as a consequence of this, also cuts costs.

## **GEA CIPClean Separator – use cleaning media longer**

The principle is simply ingenious: the clarifying and reintroduction into the system helps you to save in four different ways: on fresh water demand, on wastewater discharged, on the CIP medium, which remains in the process for longer, and on energy, thanks to the longer use of the hot CIP fluid.

Large quantities of CIP media are utilized to ensure hygienic process management – the sustainability of this essential process step can be significantly increased with a GEA CIPClean Separator.



# SINGLE-TANK

---

## Setup option one – also for mobile use

A **single-tank solution** in combination with the CIPClean Separator promises appropriate flexibility. In this setup, the contents of the tank are continuously clarified in the cycle.

### Requirements and supply details

- Three machine sizes for capacities from 1,000 to 10,000 l/h
- Standardized skid with stainless steel frame, including separator and feed control and manual outlet pressure regulation
- Options: feed pump, solids pump, vibration sensor, control water pump, turbidity monitoring for feed and outlet, automatic outlet pressure regulation

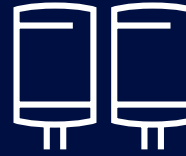

# MULTI-TANK

---

## Setup option two – for faster clarification

The **multi-tank solution** speeds things up and reduces the prep time of the CIP medium by clarifying the volume only once and then passing it to the CIP stor-

age tank. Due to the considerably higher effort required for installation, these setup options are, above all, suitable for permanent, stationary use.



# EXTENSION

---

of service life  
and reusability

due to clarification of CIP media

# Make every drop matter.

GEA separators are a key component of an enormous variety of industrial processes – and that's why they can play a decisive role in unlocking savings potential, for example, in combination with the GEA Centrifuge Water Saving Unit – a reasonably priced option that saves cooling water.



## GEA Centrifuge Water Saving Unit – sustainable separator cooling

The compact unit makes the difference – as an add-on for the reduction of freshwater demand in cooling processes, it saves both costs and resources. And it does so with a **size equivalent to the height of two moving boxes**, an **installation time of a maximum of half a working day**, and low overall investment costs. It is available for new plants and as a retrofit solution for existing installations.

**The potential savings are much bigger than you would expect from something so small.**

## How does it work?

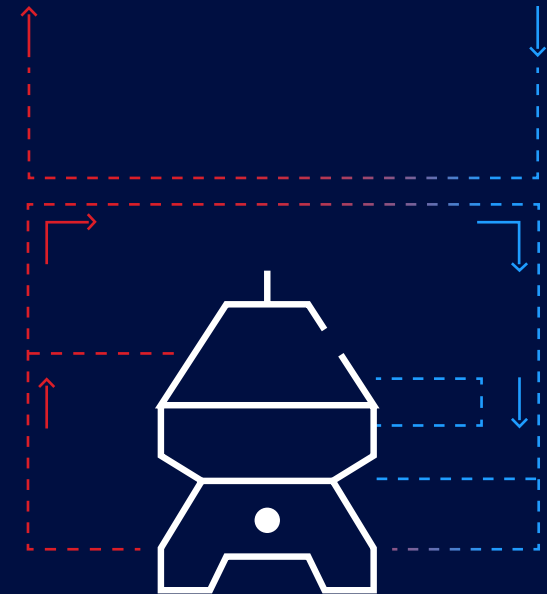

The Water Saving Unit works with two separate water cycles: while motor cooling is constantly required during operation, cooling for the hood and catcher is automatically activated only when required by the process.

The consequence: significantly optimized energy consumption in comparison with the standard production process, in which energy is needed for the pumping, cleaning, processing, and disposal of the cooling water required for the safe operation of the centrifuge.



### Paying attention to annual water consumption

Depending on the machine setup, the Water Saving Unit enables our customers to save 1 million liters or more of fresh water by recycling the cooling water. The following calculation takes a GEA separator with direct drive as an example. Under the assumption that **180 l/h** is required for cooling the hood, the solids catcher, and the motor drive – and that for **20 hours per day on 350 production days per year** – we arrive at an annual water consumption figure of approximately **1.3 million liters**.

### Requirements and supply details

- The Water Saving Unit comprises a control system, a circulation pump, a heat exchanger, valves, and internal piping
- It assists the centrifuge with a flow rate of 13 l/min at an adjustable operating temperature from 10 to 30°C
- What's needed: glycol mixture or ice water with a minimum flow speed of 15 l/min and a pressure of at least 2 bar



# 1.3

million liters  
per year saved

for cooling purposes

# A pilot case for significant water savings.

On the way to making their dairy in Neuenkirchen climate-friendly, the long-established company Privat Molkerei Naarmann has taken advantage of the opportunity to lower the costs of cooling its GEA separators and conserve resources at the same time.

The problems are ever-present – water shortages, rising costs, and increasingly strict regulations and standards dominate the market, but Molkerei Naarmann rethought their situation before it got critical and started a pilot project with GEA.

## Pioneer in rethinking production processes

Since its founding in 1903, Naarmann's dairy has successfully combined the production of premium quality dairy products with the conservation of resources. Based on the long-standing partnership with GEA, the pilot project at the dairy has now been able to unlock further sustainability potential – with a new water-saving technology for separator cooling.

## The GEA Centrifuge Water Saving Unit has delivered

As an add-on unit for a GEA MSI 400 Separator (processing capacity of 40,000 l/h), the GEA Centrifuge Water Saving Unit was able to save the dairy **300 liters of water per hour**. That makes over one million liters per year. Other convincing benefits are the **fast amortization** and **low-maintenance operation**.

“The issue of sustainability has taken on a whole new dimension today.”

Andreas Naarmann,  
Managing Director



## Amortization variables

The precise assessment of potential savings in terms of resources depends on a number of factors, such as

- the intensity of use
- the type of separator employed
- whether town water or well water is used
- how high wastewater charges are
- the energy costs incurred for the treatment of cooling water



# MAKE SENSIBLE USE OF RESOURCES. AND SAVE COSTS.

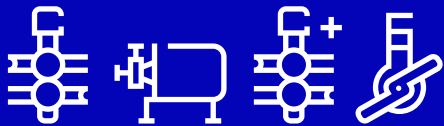

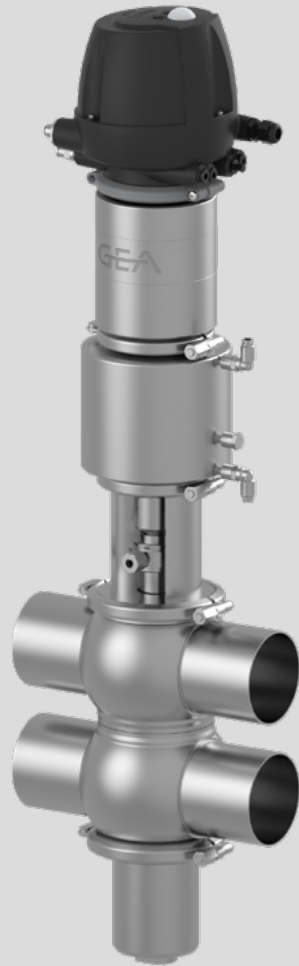

# Small changes, big impact.

You'll find some real advantages in the ins and outs of your cleaning processes using GEA Flow Components – which include valves, pumps, and cleaners. Read on to learn more about how to realize considerable savings – starting with LEFF®.

## **LEFF® function in GEA valve control tops – for highly efficient cleaning effects**

Mixproof valves perform time-controlled, full-stroke seat lifting in order to clean the valve seats and the leakage chamber. LEFF® is the smarter cleaning solution: the opening of the valve is still time-controlled, but now path-optimized, increasing the flushing intensity and shortening flushing times – a clear benefit in terms of sustainability!

### Benefits and supply details

- LEFF® is integrated as a standard feature in the T.VIS® A-15 control top – the best choice for mixproof double-seat valves
- No complicated programming required in the PLC
- No additional system technology required
- Automatic monitoring of the lift function
- Significant cost reductions, for example, savings on CIP media, water, energy, etc.

“The principle is based on a flip-flop movement of the valve discs. At the moment, when the valve disc lifts from the seat and opens up a cleaning gap, the cleaning medium flows in. That’s when the shear forces are at their greatest and they clean most effectively.”

Bernd Prorath,  
Product Manager Hygienic Valve Technology



# 90

percent savings of CIP  
cleaning media and water



# Savings of 92% confirmed.

One of Sweden's biggest milk processing companies has experienced the savings potential of LEFF® in a direct comparison.

Although the Swedes love innovations, they are also extremely pragmatic: up to now, do it, save, and fulfill the demands for sustainability has been the name of the game.

## Two new valve blocks fitted with LEFF®

At the heart of the comparison: conventional valve seat cleaning against implemented LEFF® functionality. The test compares the CIP consumption of two identical valve blocks equipped with mixproof valves – one with and one without LEFF®.

**A 92% less CIP medium** speaks for itself. A single cleaning cycle of one two-inch mixproof valve with LEFF activated showed that it was possible to save 0.19 liters of alkaline CIP medium (**277 l per year**) and 0.12 liters of acidic CIP medium (**175 l per year**). This also means that all other consumption factors from fresh water and wastewater to energy are positively influenced by LEFF®.



**Are you ready to save?**

Try the LEFF® principle for high performance!

# The biggest gain is the regain.

Recover a valuable product, save fresh water, and avoid wastewater in the production chain – that's how GEA VARICOVER® Product Recovery Systems contribute to sustainability.



“The higher the viscosity of a product and the longer the piggable section, the more the product can be recovered and the lower the water consumption.”

Christian Blecken,  
GEA System and Application Support at the  
Competence Center for Hygienic Valve Technology

## GEA VARICOVER® – as waste-free as possible

Cleaning pipes in production processes is a hidden source of enormous optimization potential. In this process, a hygienically clean plug, a so-called pig made of soft plastic, is propelled through the piping system to push out valuable product residues and assure that the system is **cleared of residues with a minimum of flushing water.**



### Every drop counts, especially in process pipes

Product recovery or pigging systems have become an important tool that helps companies in many cases to save product by recovering the valuable residues from the pipelines before the pipes are flushed and cleaned. This ensures that raw materials are processed with minimal waste, following the principle of “keeping is better than making”.

Product recovery systems also help to reduce the amount of fresh water needed in the pipe-cleaning process and also reducing subsequent wastewater treatment.

### Features

- In-line system with fully automatic cleaning of the pig
- Also available as explosion-proof version

### Benefits

- Reduction of wastewater
- Reduction of cleaning detergents and fresh water
- Recovery of valuable product

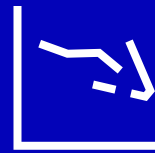
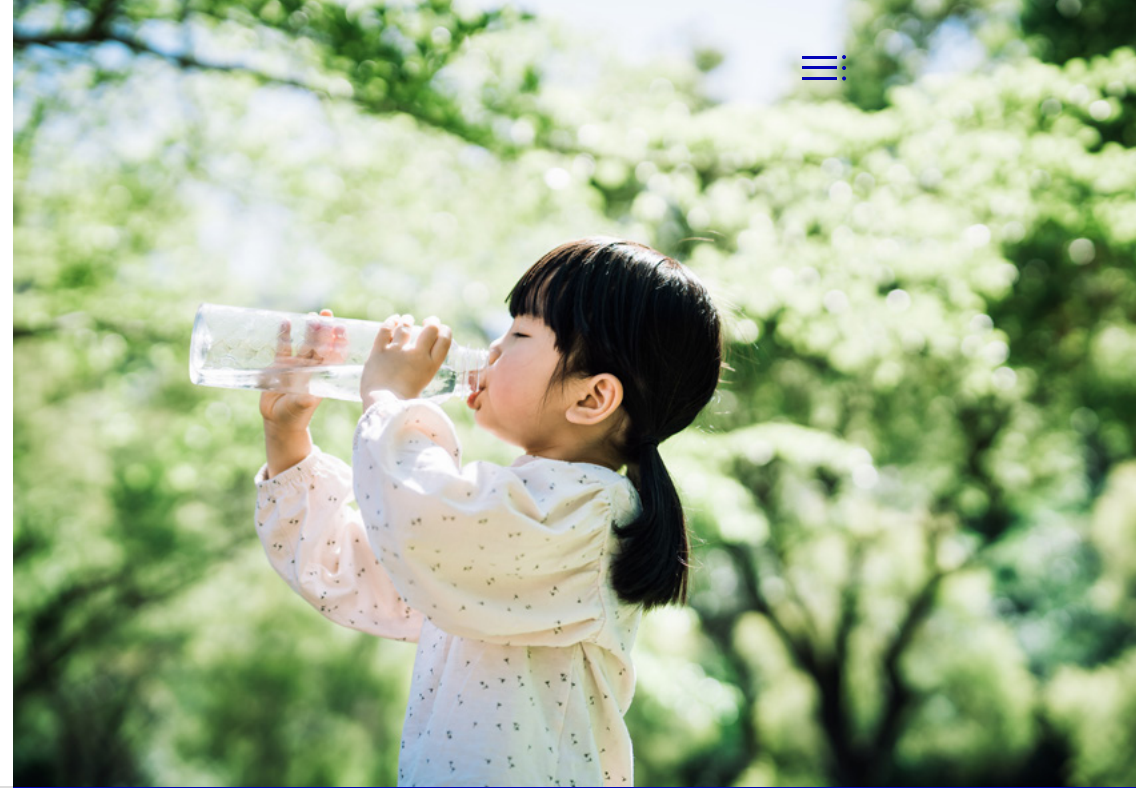

# 3x

less food waste, fresh water,  
and wastewater

# Hidden champion in the sustainability spotlight.

Doing a great job where hardly anyone can see it – GEA cleaning technology offers a complete portfolio for sustainable tank cleaning to assure the consistent quality and reproducibility of sensitive products.

## Individual GEA cleaning solutions you can completely rely on

Optimal cleaning results for your production process in a wide range of applications. For this purpose, our product portfolio offers a selection of widely differing cleaners – from static, slow-rotating, and free-rotating cleaners to orbital and index cleaners. They guarantee optimal cleaning and the conservation of resources in all soiling classes.

## Using the Dynamic Sinner's Circle as a savings guide.

Here's how you can determine the best approach to every cleaning application when you want to save energy, time, and resources. The percentage of the four elements that make up the circle will vary from application to application and will have a direct influence on the liquid volume shown at the center.



The leading players in the cleaning process.

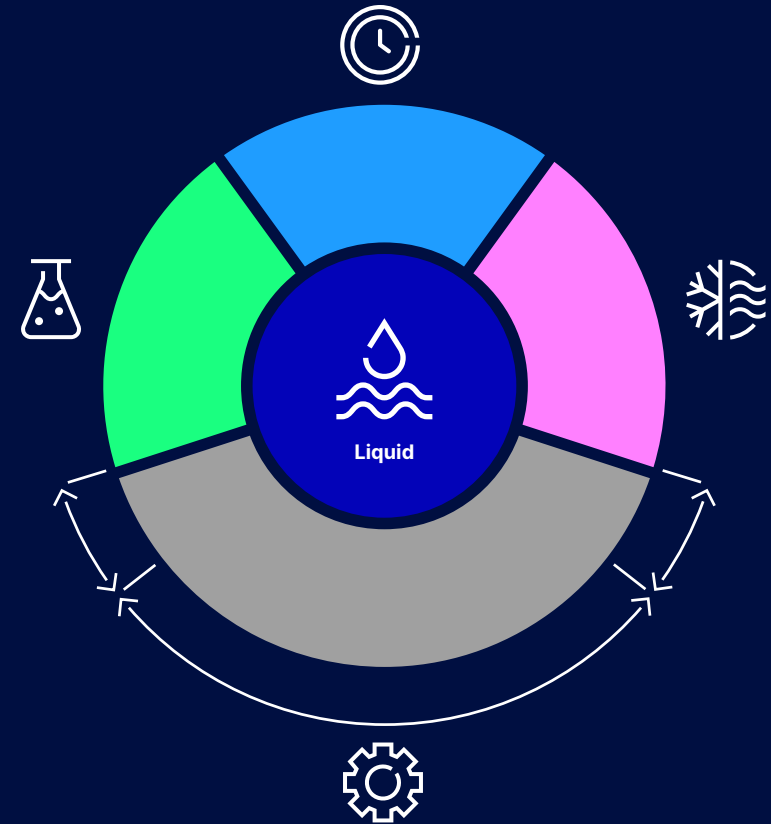

### Chemical

The cleaning agent that is used to aid the cleaning process.



### Time

The time required to adequately achieve the level of cleaning.



### Temperature

The temperature required to perform the cleaning.



### Mechanical

The force required to remove the soils (shear, impact, or friction).

### Product protection and savings as in the case of beer

GEA's modular **orbital cleaners OC200** were utilized in the fermentation tanks of a brewery instead of spray balls. It resulted in all parts of the tank benefiting from direct impact cleaning and not relying on water rundown. This enabled our customer to reduce the flow rate from more than 50,000 liters to just a little over **9,000 liters per ten-minute cleaning cycle**.

### Features and benefits

- A wide range of product series and modular adaption options for every process tank
- The cleaner types in our portfolio include static cleaners, free-rotating cleaners, slow-rotating cleaners, orbital cleaners, and index cleaners
- Assuring the safety of your products also safeguards your reputation in the eyes of public authorities, markets, media, and consumers
- Our extensive process expertise is integrated at all times

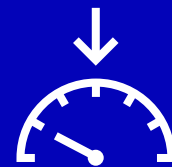

# 41,000

liters less water consumption

in just one ten-minute cleaning cycle



# The heart of GEA Flow Components.

Finding the right core components for a plant requires plenty of experience and a wide range of GEA Hilge hygienic pumps that combine economy, efficiency, and reliability.

## GEA Hilge Hygienic Pumps – smart-sized, energy-efficient

The Hilge hygienic pump portfolio offers **centrifugal pumps** and **positive displacement pumps** for almost all processing tasks and capacities.

Expert advice is invaluable when it comes to choosing the right hygienic pump.

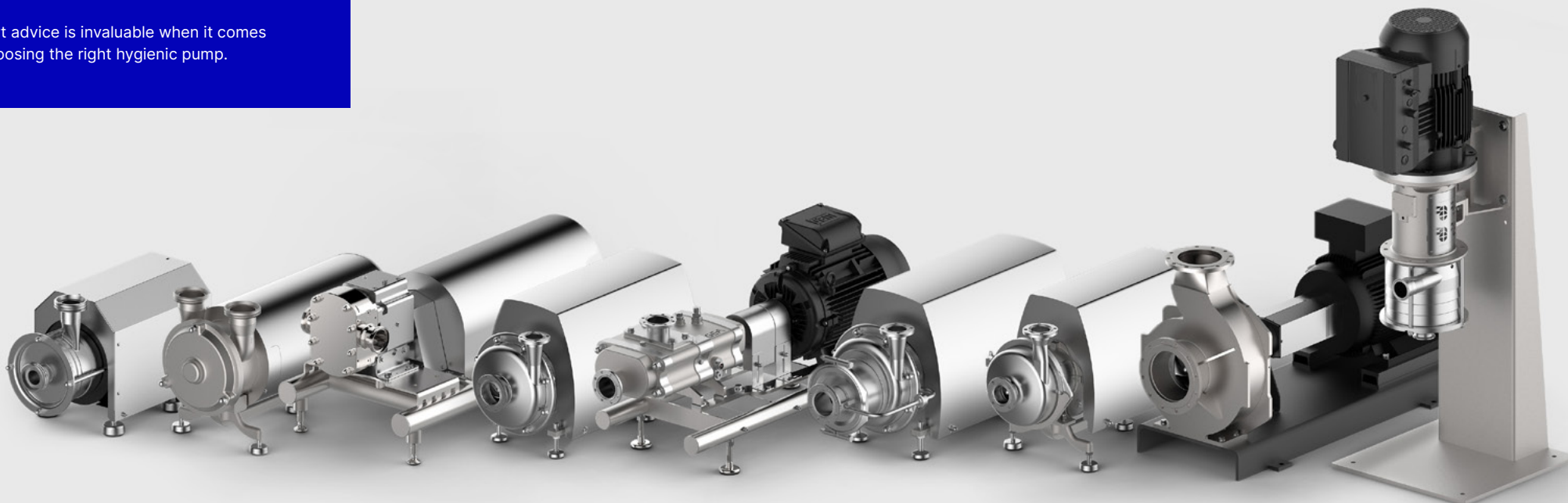



### GEA Hilge NOVATWIN+ means better flexibility and design

If your processes require the pumping of sensitive media with widely varying viscosities, the range of GEA Hilge NOVATWIN+ twin-screw pumps has exactly the right pump for your needs. These versatile two-in-one pumps for products and CIP media eliminate the need for investing in a CIP pump, piping, valves, and their control systems. The redesigned pumps offer higher flow rates and, in two-thirds of all cases, allow the installation of a pump with smaller dimensions, which means an up to 23% reduction of the materials used in manufacturing. Assuming a power consumption of 10,000 kWh, this means that the new pump design can also save you around 1,000 kWh.

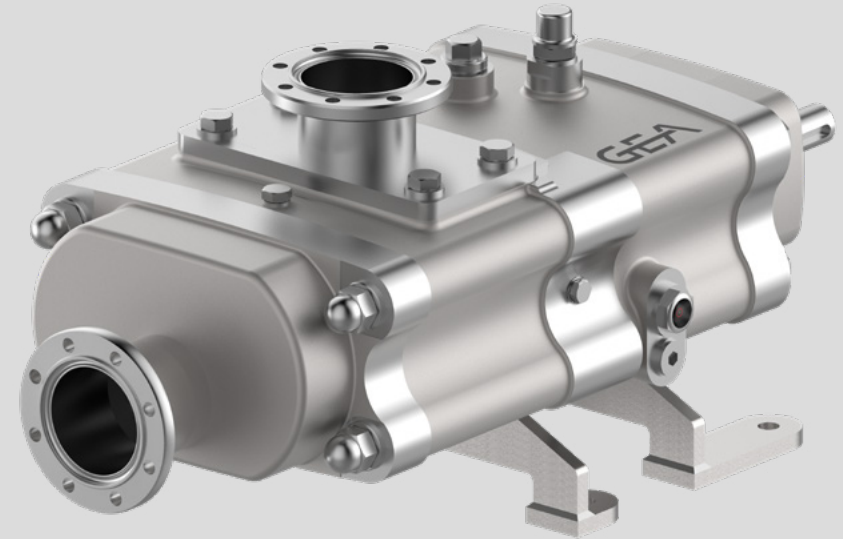

#### Features and benefits

- Patented easy screw adjustment directly on screws without oil release and disassembly of gear box
- Ideal adaptation to customer needs in beverage, dairy, and pharma industries through numerous combinations of screw diameters and pitches
- Maintenance costs for only one pump



Up to

# 10

percent energy savings

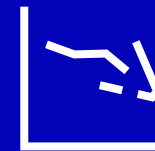

and

# 23

percent material reduction

# Renewable is the better new.

Minimizing the material required when replacing wear parts is another example of the sensible use of resources, as in the case of the stainless steel bellows used in aseptic valve technology. The GEA send-in repair service makes it possible – and at a fraction of the costs at that.

## GEA Aseptomag® valves – repairing is caring

The replacement of wear parts at regular intervals is absolutely essential. There is, however, a more sustainable alternative. Just because the stainless steel bellows are welded to the adjacent valve parts, **this doesn't mean that the entire internal assembly has to be exchanged and scrapped.** A partial renewal fulfills all the necessary requirements.





### Quicker than changing clothes

The “quick-change act” for GEA Aseptomag® internal assemblies can be carried out at the customer’s production facility. The only thing required to do so is a backup unit with new bellows to go right back into production. After the old internal assembly has arrived at our production site, an experienced welder cuts out the stainless steel bellows and installs the replacement in new-product quality. We handle around **2,500–3,000 repairs for bellows replacement per year**, at times more than a hundred for a single customer in one shipment.



### Features and benefits

- The larger the valve and the internal assembly, the higher the savings potential
- We recommend keeping two consumables in stock for every fifth currently installed aseptic valve of the same type
- The GEA Aseptic Valves Competence Center would be pleased to provide you with a repair plan that meets your specific requirements



# 60

percent savings on material costs with renewables

# REIMAGINE SUSTAINABILITY IN LIQUIDS HOMOGENIZATION.

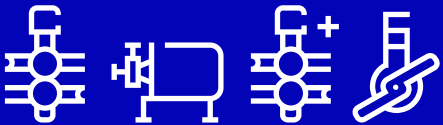
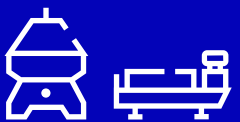

# Making the world of homogenizers sustainable.

The reduction of the consumption of valuable resources brings substantial benefits in terms of economy and environmental protection in the world of homogenizers. Modular expansion brings additional benefits, whether in the form of retrofitting options or accessories for new machines.



**In focus:** the Ariete Series, flexible and versatile, performs with excellent results in terms of sustainability and resources optimization.

## Everything begins with TCO

The benchmark for all optimization measures is the combination of best machine performance and the best possible TCO (Total Cost of Ownership). Taking a mid-size homogenizer for the food and dairy sector as an example, the cost factors throughout the entire service life of the machine are:

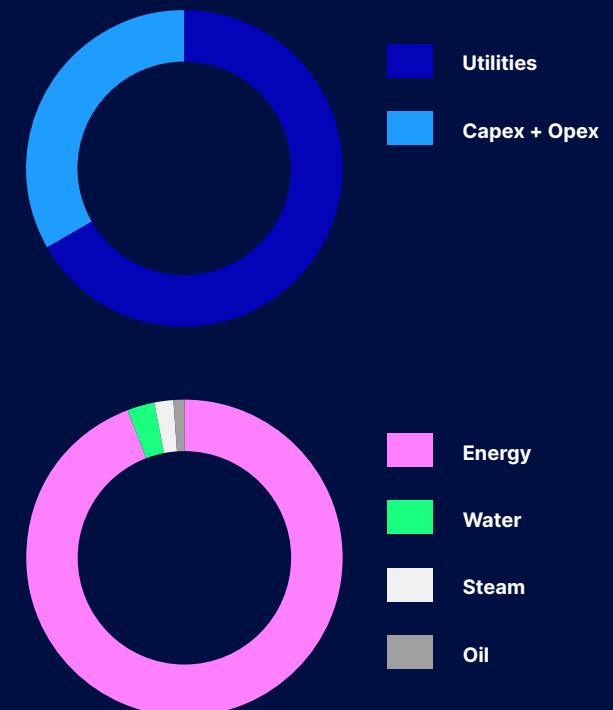



# How the Ariete Series ensures successful savings with the Net\_0 configuration.

## In the right place at the right time with the right solution

From NanoVALVE to OPS – there are numerous options and devices for the homogenizer that can make a difference to realize savings. In the following, we provide an overview of the best configuration possible, the so-called Net\_0, where the consumption of energy, water, oil, and product waste is significantly reduced.

**A shining example of sustainability:**  
the Net\_0 configuration for the Ariete homogenizers.

1

**up to 30% less energy**  
New homogenizing valve generations

2

**15% less water**  
Plungers water recirculation

3

**85% less water**  
Gearbox and transmission water recirculation

4

**80% less oil**  
Oil purification system

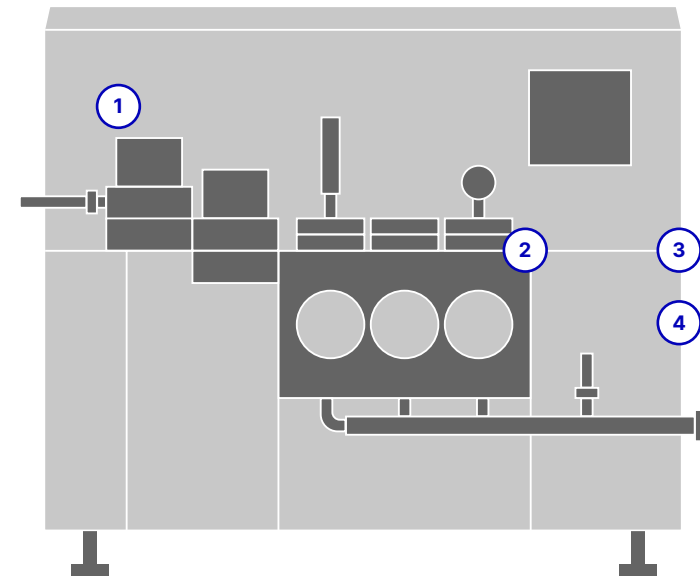



### Maximum efficiency – sustainability follows the right choice

GEA's 70 years of experience in high-pressure homogenization have made a headstart in providing the optimal solution in any homogenization tasks. From NanoValve® to NisoX-Valve, the **various homogenizing valve designs** are fundamentally important along with the valve geometry. In the end, our customers benefit from this through an increase in efficiency and a **reduction in operating pressure, providing energy savings and optimal use of the ingredients and resources.**

### Valve types and supply details

- NanoVALVE® – suitable for food, dairy, beverages, and chemical emulsions process
- NanoVALVE® HP – high pressures (up to 700 bar), ready to offer advantages, especially in terms of homogenization effect and energy savings of new applications
- NiSoX-Valve – this design optimizes different fluid dynamic effects, employing energy in the most efficient and effective way



Up to

# 30

---

percent lower operating pressure

and equally high energy savings  
(e.g. NanoValve® in dairy application)

### When the goal is zero water consumption

When it comes to water as a resource, every drop counts – regardless of whether it is fresh or waste water. GEA homogenizers offer a choice of two systems for the reduction of the wastewater load in the parts of homogenizers that require cooling and lubrication – **controlled circulation systems for piston lubrication** and **oil coolers**. Zero wastewater systems pave the way to the future, particularly in countries that suffer from extreme water shortages.

### GEA puts the pressure on water stress

The Homogenizer business unit pursues the key objective of the GEA Sustainability Strategy, “**zero freshwater use by 2030**”, with innovative solutions – for instance, with the customer-specific high-pressure homogenizers of this series that are already contributing to the achievement of this goal.



Up to

**100**

---

percent water reduction

as per the zero-waste strategy

**GEA Oil Purification System –  
the guarantee for consistently high oil quality**

The **bypass filtering unit** guarantees **continuous oil regeneration through the removal of particles, water, and corrosive gases**. The lifetime, quality, and safety of the oil are all significantly improved by OPS. This unit works independently from the homogenizer, ensuring that your maintenance work does not affect machine operations and that customers can look forward to enormous **savings in terms of costs and time**. Even severely contaminated waste oil can be purified.

**Steps and supply details**

- OPS is designed for continuous operation, independent of homogenizer operation
- Step 1: utilizes 100% long-staple cotton fibers for capturing particles from the size of 1 micron as well as sludge
- Step 2: is a flash evaporation process that dehydrates the oil and removes chemical contaminants
- No condensation and no contamination
- Short payback on investment



12

thousand hours of estimated new oil lifetime



80

percent less oil consumption



# OPEN UP NEW HORIZONS FOR EFFICIENCY.

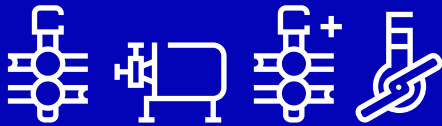

# Digitalization ensures good service health and more savings.

The sustainable goal is to further enhance GEA machines and systems with state-of-the-art digital solutions for the benefit of saving resources, money, and nerves. We're well on our way to achieving this – let's see how!

## **The best solution: GEA Online Condition Monitoring**

As a fully-featured GEA PerformancePlus service module, it serves as an IOT gateway for continuous transmission of process data from the GEA IO Control System to a cloud-based platform with customizable dashboards. Should customers require qualified GEA remote support or software updates, direct access is enabled by a customer-controlled secure gateway.

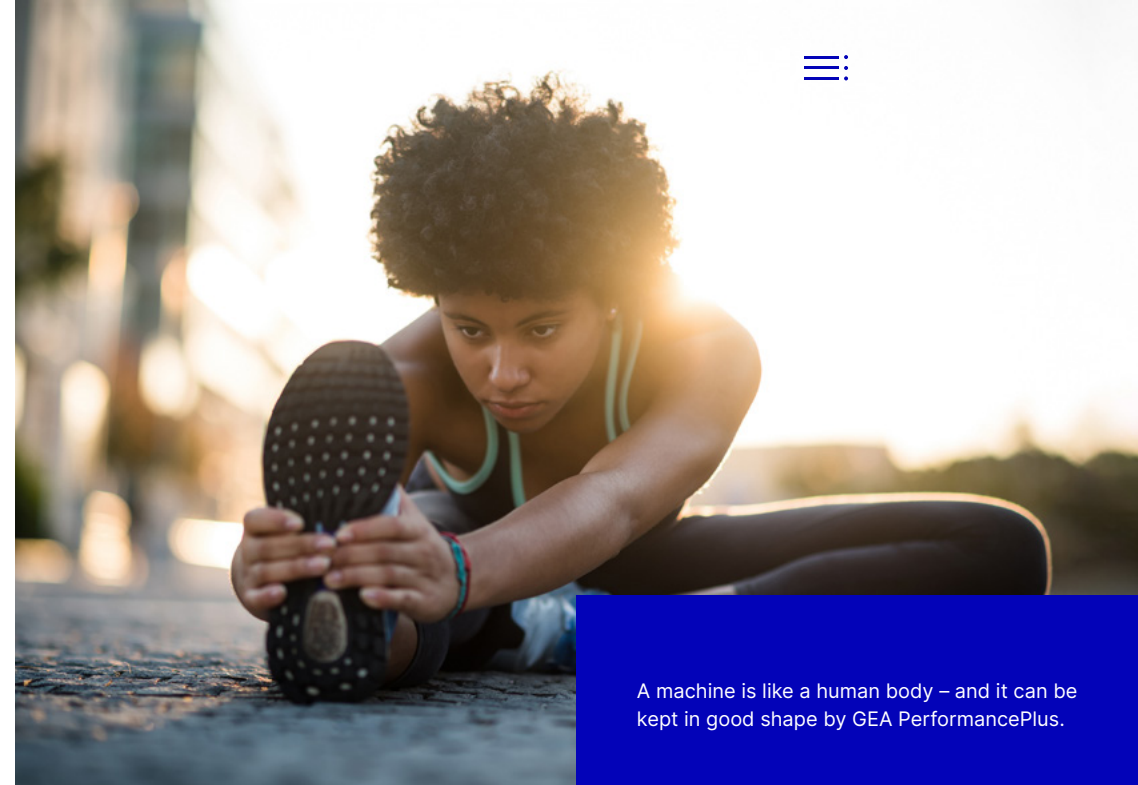

A machine is like a human body – and it can be kept in good shape by GEA PerformancePlus.

## **A digital service product for comprehensive analysis**

This advanced condition-monitoring technology allows even more efficient realization of performance targets for GEA separators and decanters as well as GEA homogenizers. Reliable operating times, sustainable profitability, and continuous growth in harmony with the environment are all made possible by the wide range of options offered by this tailored support concept. The digital service package goes beyond classic maintenance and is an ideal complement to every Industry 4.0 strategy.

# UNIDENTIFIED SAVING OPORTUNITIES? WE CAN HELP.

A better world starts with an honest interest- and target-based conversation as peers and equal partners. Feel free to contact us if you are looking for better products.

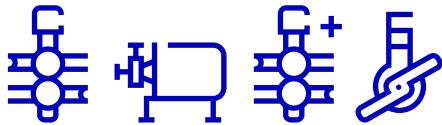
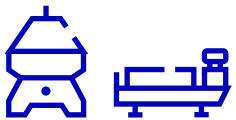

## Your road to more resource efficiency

Discover your individual savings potentials within each of our three business units!

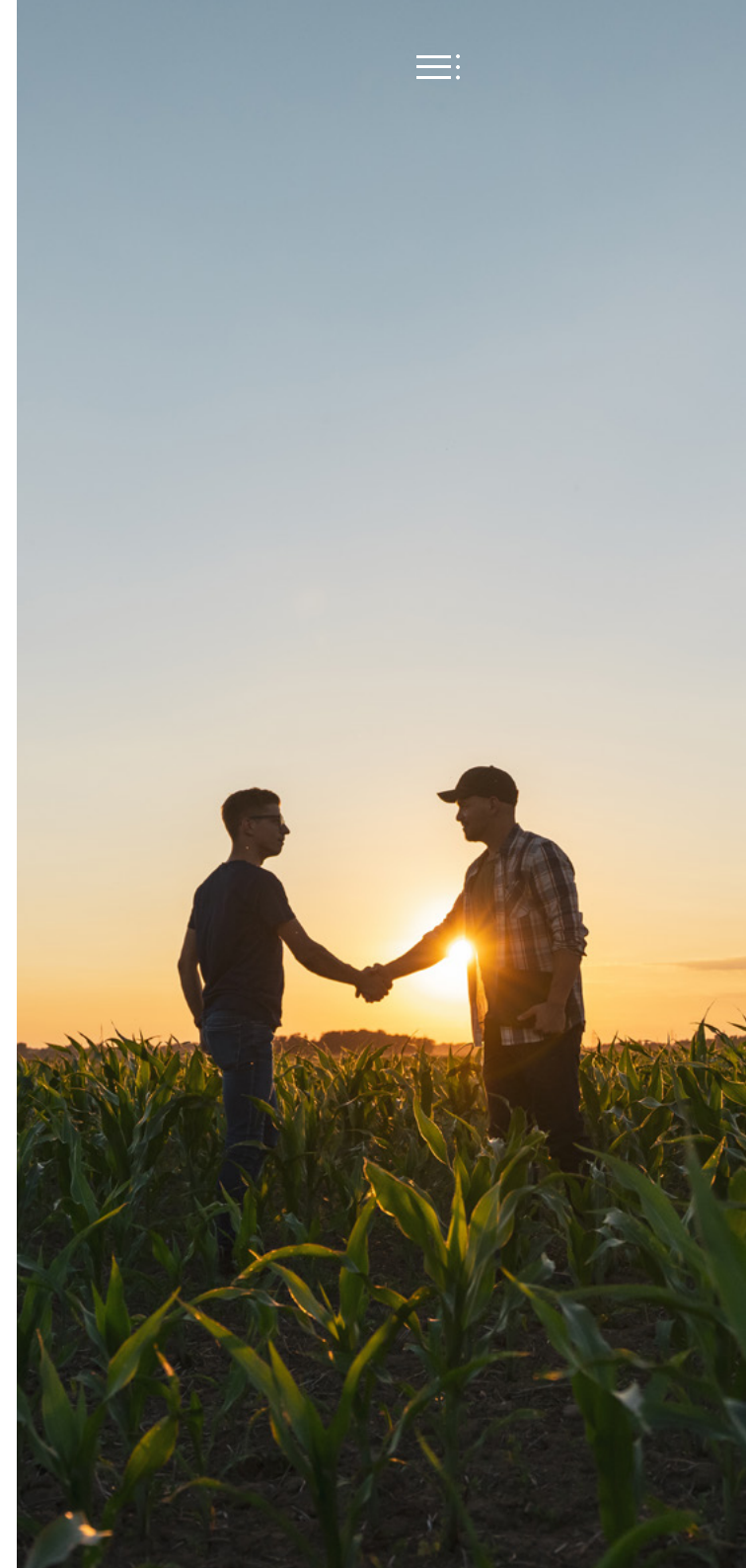

**WANT A  
BETTER WORLD?  
CONTACT US.**