

OPERATING INSTRUCTIONS

Original instructions

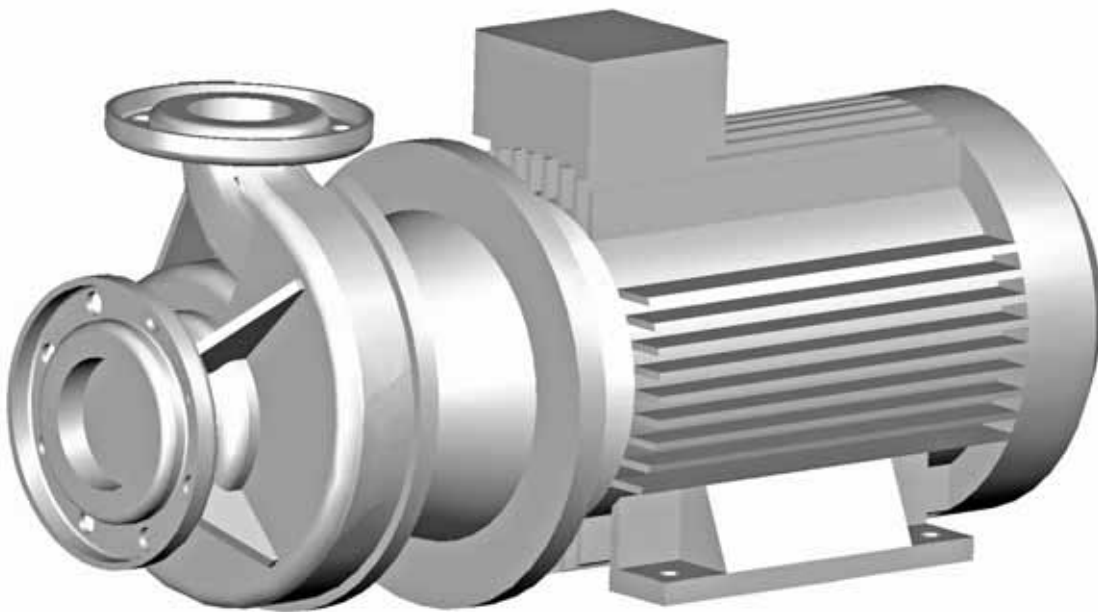

GEA Hilge MAXA L

Hygienic Pumps

GEA Hilge Niederlassung der GEA Tuchenhagen GmbH

BA.223.LYY.001.01.25.GB

Language: English

EC - Declaration of conformity for machines
in accordance with EC Machinery Directive 2006/42 /EC, Annex II 1. A

Manufacturer: **GEA HILGE**
Niederlassung der GEA Tuchenhagen GmbH
Hilgestraße 37-47
D 55294 Bodenheim

We, as manufacturer, declare in sole responsibility that the machinery

Product: Centrifugal pump
Model / Type: GEA Hilge MAXA ADAPTA, ADAPTA-SUPER
GEA Hilge MAXA BLOC
GEA Hilge MAXA L, L-SUPER
GEA Hilge MAXA CN, CN-SUPER
GEA Hilge MAXA C

complies to all relevant provisions of this and the following directives:

Relevant EC Regulations: 2006/42/EG EC Machinery Directive

Applied harmonized standards, in particular: EN 809:1998/A1+AC(D)

EN ISO 12100:2010

Remarks: We also declare that the special technical documentation for this incomplete machine has been created in accordance with Annex VII, Part A and we obligate to provide these upon reasoned request from the individual national authorities by data transfer.

Authorized person for compiling and handing over technical documentation: **GEA HILGE**
Niederlassung der GEA Tuchenhagen GmbH
Hilgestraße 37-47
55294 Bodenheim, Germany

Bodenheim, date 05.12.2022



Karsten Becker
Managing Director



i. V. Dr. Danijel Anciger
Product Development Manager

UKCA - Declaration of Conformity

We herewith declare,

GEA HILGE
Niederlassung der GEA Tuchenhagen GmbH
Hilgestraße 37-47
D 55294 Bodenheim

that the machinery

Denomination: Centrifugal pump
Model / Type: GEA Hilge MAXA ADAPTA, ADAPTA-SUPER
GEA Hilge MAXA BLOC
GEA Hilge MAXA L, L-SUPER
GEA Hilge MAXA CN, CN-SUPER
GEA Hilge MAXA

is in conformity with the following UK-directives, provided that the site conditions for the commissioning are met as specified in the engineering documents, in particular in the operation manual:

Supply of Machinery (Safety) Regulations 2008, 2008 No. 1597

Designated standards used: EN 809:1998+A1:2009+AC(D)
EN ISO 12100:2010

Authorized person for compiling and handing over technical documentation: **GEA Mechanical Equipment UK Ltd**
Westfalia House
Old Wolverton Road, Old Wolverton, Milton Keynes
MK12 5PY, United Kingdom

Bodenheim, 05.12.2022



Karsten Becker
Managing Director



i. V. Dr. Danijel Anciger
Manager Product Development

1. Introduction	5
1.1 Target group	5
1.2 Symbols and formatting	5
1.3 References to the document	5
2. Safety	6
2.1 Instructions for the operator	6
2.1.1 General information	6
2.2 Safety instructions in the operating manual	6
2.3 Identification of instructions in the operating manual	7
2.3.1 Structure of safety instructions	7
2.4 Qualifications and training of personnel	8
2.5 Hazards caused by failure to follow the safety instructions	8
2.6 Safety-conscious work	8
2.7 Safety instructions for the operator / user	9
2.8 Unauthorized modifications and production of spare parts	9
2.9 Improper operation	10
2.10 Transport	10
2.11 Cleaning	11
2.12 Repair contract	11
3. Product description	12
3.1 Pump overview	12
3.2 Description	13
3.2.1 Areas of application	13
3.3 Proper usage	13
3.3.1 Pumped liquids	13
3.3.2 Minimum flow rate Q_{min}	13
3.3.3 Connections and pipelines	13
3.3.4 Motor activation	13
3.3.5 Design	13
3.4 Technical data	14
3.4.1 Pump denomination	14
3.4.2 Pump serial number	14
3.4.3 Nameplate	15
3.4.4 Performance data	15
3.5 Weights	16
3.5.1 Noise emissions	18
3.5.2 Maximum operating temperatures	20
3.5.3 Maximum operating pressure	20
4. Mounting, installation and connection	21
4.1 Inspection before pump installation	21
4.1.1 Check failure-free running of the impeller	21
4.2 Set-up and alignment of the pump assembly	21
4.3 Installation in the pipeline	22
4.3.1 Space requirements	24
4.3.2 Reduction of noise and vibration	25
4.4 Connections	26
4.4.1 Flushing connection for the single mechanical seal	26
4.4.2 Flushing connection for double mechanical seal	27
4.4.2.1 Double mechanical seal	27
4.4.2.2 Double mechanical seal - tandem arrangement	28
4.5 Electrical connections	28
4.5.1 Star connection	29
4.5.2 Delta connection	29

4.5.3 Checking the direction of rotation after connection	29
---	----

5. Start-up / shut-down 30

5.1 Start-up	30
5.1.1 Check application conditions	30
5.1.2 Starting up the pump	30
5.1.3 Functional check of the mechanical seal	30
5.2 Shut-down	31
5.2.1 Shutting down the pump	31
5.2.2 Cleaning the pump after shut-down	31

6. Maintenance / servicing 32

6.1 Safety instructions for maintenance, inspection and installation work	32
6.2 Maintenance of the pump	33
6.3 Maintenance of the motor	33
6.4 Maintenance of L bearing	33
6.4.1 Design L bearing	33
6.4.1.1 Grease quantities for roller bearings during assembly	33
6.4.2 Bearing replacement	33
6.4.2.1 Premature bearing replacement	33
6.4.3 Bearing lubrication	34
6.4.3.1 Cylinder bearing greases	34
6.4.4 Re lubrication L-bearing	35
6.5 Assembly / Disassembly	36
6.5.1 Parts overview	36
6.5.2 Instructions for disassembly	37
6.5.3 Instructions for assembly	37
6.5.4 Assembly of MAXA-L	38
6.5.5 Overview mechanical seal Arrangements	39
6.5.6 Assembly of the single mechanical seal (A)	40
6.5.7 Assembly of the single mechanical seal (B)	41
6.5.8 Assembly of single mechanical seal (C)	42
6.5.9 Assembly of single mechanical seal (D)	43
6.5.10 Assembly of double mechanical seal (E)	44
6.5.11 Assembly of the impeller and volute casing	45
6.6 Troubleshooting	47
6.7 Disposal	48
6.8 HILGE assembly tool kit	49
6.8.1 Content and use	49

7. Certificate of non-objection 50

7.1 Certificate of non-objection	50
----------------------------------	----

1. Introduction

Overview

This section describes the requirements which are important for reading and understanding this manual. You will learn the symbols and formats that make the reading easier.

1.1 Target group

This operating manual is intended for:

- the operators of the pump
- maintenance and repair personnel.

It is assumed that all such personnel will have the basic technical background required for the start-up, maintenance, and repair of pump systems.

Sections aimed only for specially authorised personnel are indicated by a preceding notation to this effect.

1.2 Symbols and formatting

The following symbols and formats are intended to make it easier to read this document:

- Listed items

Instructions

Instructions that must be carried out in a specific sequence are numbered in the corresponding order.



Important information and helpful tips are identified with the index finger symbol.

Safety instructions

The system used to identify safety instructions is described in section 2.3, page 7.

1.3 References to the document

Copyright

This document may not be copied, translated into other languages, or made available to third parties without our explicit written approval.

Technical changes

Design variants, technical data, and spare part numbers are subject to technical change.

The right to make changes for the sake of further technical development is reserved.

2. Safety

Overview

This section describes what you have to consider for your own safety. You will learn the structure and identification of safety instructions. Read this important section attentively!

2.1 Instructions for the operator

2.1.1 General information

All our pumps are professionally packed before they leave our warehouse to avoid damage during transport.

Unpacking If, after carefully unpacking and inspecting the shipment, you however find damage, you must promptly inform the shipping agent (railway, post office, lorry driver, shipping line, etc.).

Your claim should be filed with the shipping agent. The shipping risk passes to the customer as soon as the shipment leaves our warehouse.

Storage If the pump is not put into service immediately, it is important that it is stored properly to ensure that it will function correctly later. This is just as important as proper installation and maintenance.

The pump must be protected from cold, moisture, and dust as well as from mechanical influences.

Specially trained personnel is required to install and maintain the pump properly.

2.2 Safety instructions in the operating manual

Read safety instructions! The operating manual contains all the basic information required for the set-up, operation, and maintenance of the pump. The installer as well as the technical personnel or operator responsible for the pump must therefore read this manual before installing and starting the pump. The operating manual must always be available at the site where the machine/system is being used. Not only the general safety instructions presented in this section but also the specific safety instructions in later sections must be followed.

Safety

2.3 Identification of instructions in the operating manual

Symbol The safety instructions presented in this operating manual are identified as shown below.

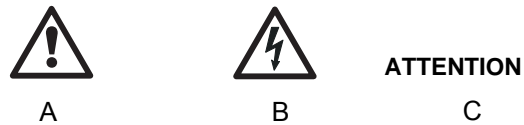

K.0319V1 | K.0320V1

Fig. 1 Symbol for safety instructions

- A: Failure to follow these safety instructions can endanger personnel.
- B: Safety instructions which involve warnings against electrical voltage.
- C: Failure to follow these safety instructions can endanger the machine and its operation.

Signal words In order to classify the safety labels they are distinguished by the following signal words:



- **Danger**
Characterises an imminent hazard with a high risk which can cause death or grievous bodily harm.
- **Warning**
Characterises a possible hazard with medium risk which can cause death or bodily harm if it is not avoided.
- **Caution**
Characterises a hazard with minor risk which can cause minor or medium bodily harm if it is not avoided.

Don't remove instructions from machine

Instructions attached directly to the machine, such as rotational direction arrow must be noted and kept in completely legible condition.

Damaged or illegible instructions must be replaced.

2.3.1 Structure of safety instructions

<p>WARNING</p> 	<p>Description of danger!</p> <ul style="list-style-type: none"> ▲ Possible consequence. ▷ Action to eliminate the danger.
<p>Example:</p>	
<p>DANGER</p> 	<p>Electrical shock if electrical parts are touched!</p> <ul style="list-style-type: none"> ▲ Death, serious bodily injury, damage to property. ▷ Before attempting to diagnose any fault, make sure that the main switch has been switched off. It must be ensured that the electricity supply cannot be accidentally switched on.

2.4 Qualifications and training of personnel

The employees operating, maintaining, inspecting, and installing the pump must have the appropriate qualifications for this work. The operator must define in detail the tasks for which the employees are responsible, the tasks of which they are in charge, and the manner in which they are supervised.

If the employees do not have the necessary knowledge, they must be instructed and trained accordingly. This can be done, if necessary, by the manufacturer/supplier under contract to the operator. The operator must also guarantee that the employees fully understand the contents of the operating manual.

2.5 Hazards caused by failure to follow the safety instructions

If these safety instructions are not followed employees, the machine itself and the environment will be in danger.

Failure to follow the safety instructions can lead to the loss of the right to file claims for damages.

Failure to follow instructions can, for example, lead in particular to the following hazards:

- Breakdown of important functions of the machine/system
- Failure of recommended methods of maintenance and repair
- Endangerment of personnel by electrical, mechanical, and chemical hazards
- Endangerment of the environment by leakage of hazardous materials.

2.6 Safety-conscious work

The safety instructions given in this operating manual, the existing national regulations for accident prevention, and any applicable internal working, operating, and safety instructions of the operator must be followed.

Safety

2.7 Safety instructions for the operator / user

CAUTION	Hot or cold mechanical components!
	▲ Serious bodily injury. ▷ Take structural measures to prevent contact with them!

WARNING	Trapping hazard!
	▲ Death, serious bodily injury, damage to property. ▷ Do not remove protection against contact with moving parts (e.g. coupling guard) while the machine is operating. ▷ Replace defective safety equipment immediately.

WARNING	Contact with hazard substances (e. g. inhale)!
	▲ Death, serious bodily injury, damage to property. ▷ Drain away leakage of hazardous pumping media in such a way that there is no danger to personnel or to the environment. ▷ Follow legal regulations. ▷ If shaft seal fails switch off the pump. Replace seal before next start-up.

CAUTION	Tripping hazard from electric power cable!
	▲ Death, serious bodily injury. ▷ Route the electric power cable in such a way that no one can trip over it (in case of portable pumps).

WARNING	Electrical hazard!
	▲ Death, serious bodily injury. ▷ Only use acceptable electric cables and plugs.

2.8 Unauthorized modifications and production of spare parts

No modifications or changes to the machine may be made without written approval of the manufacturer. In the interest of safety, only original spare parts and accessories authorized by the manufacturer may be used. The use of other parts can exempt the manufacturer from liability for damage which may thus be caused.

2.9 Improper operation

The operational reliability of the delivered machine can be guaranteed only when it is used properly as indicated in the following sections.



The given limit values may not be exceeded under any circumstances.

2.10 Transport

WARNING



Falling loads!

- ▲ Death, serious bodily injury, damage to property.
- ▷ Transport work must only be performed by persons qualified to do so, and all safety instructions must be observed.
- ▷ Use suitable load carrying equipment with sufficient capacity to transport the pump.
- ▷ Make certain there are no persons under the suspended load.
- ▷ Make certain the pump is aligned horizontally when it is lifted.

ATTENTION

Incorrect lifting points!

- ▲ Damage to property.
- ▷ Fasten the rope to suitable lifting points.
- ▷ Never fasten a rope to the pump casing or intake/discharge branch.
- ▷ In case of SUPER design¹: Remove shroud before transporting.

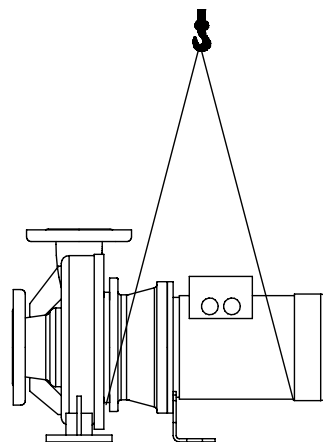

K-0176V1

Fig. 2 Attachment points for L pumps (example)

1. Option.

Safety

2.11 Cleaning

CIP and SIP methods must be in accordance with the latest current guidelines of the EC.

When special cleaning agents and methods are used, the supplier must confirm that they are safe for the materials involved.

WARNING**Pressure surge!**

▲ Death, serious bodily injury, damage to property.

▷ Before sterilisation always evacuate the system completely!

2.12 Repair contract

The duty to follow the legal regulations on work safety and the regulations on environmental protection means that all commercial enterprises must protect their employees, the public at large, and the environment from the harmful effects of hazardous materials.

Examples of legal regulations on work safety:

- the Workplace Act (ArbStättV)
- the Hazardous Materials Act (GefStoffV)
- the accident prevention regulations(BGV A1)
- and all applicable laws, rules, guidelines, regulations etc. in the country of operation.

Examples of regulations on environmental protection:

- the Recycling and Waste Law (KrW/AbfG)
- the Water Economy Law (WHG)
- and all applicable laws, rules, guidelines, regulations etc. in the country of operation.

Certificate of non-objection

The certificate of non-objection attached to the shipment is a component of the inspection/repair contract. This does not affect our right to refuse acceptance of this contract for other reasons.

The certificate of non-objection can be found on page 50.

HILGE products and their parts will only be inspected/repaired if the certificate of non-objection is present and has been correctly completed by authorized and qualified technical personnel.

Pumps which have been operated in media exposed to radiation will not be accepted.

If any additional safety measures are required even after the careful draining and cleaning of the pump, the necessary information must be provided.

3. Product description

Overview

This section describes the pump as well as its design and application. Section „Technical Data“ describes limits for application. You must know and keep these limits.

3.1 Pump overview

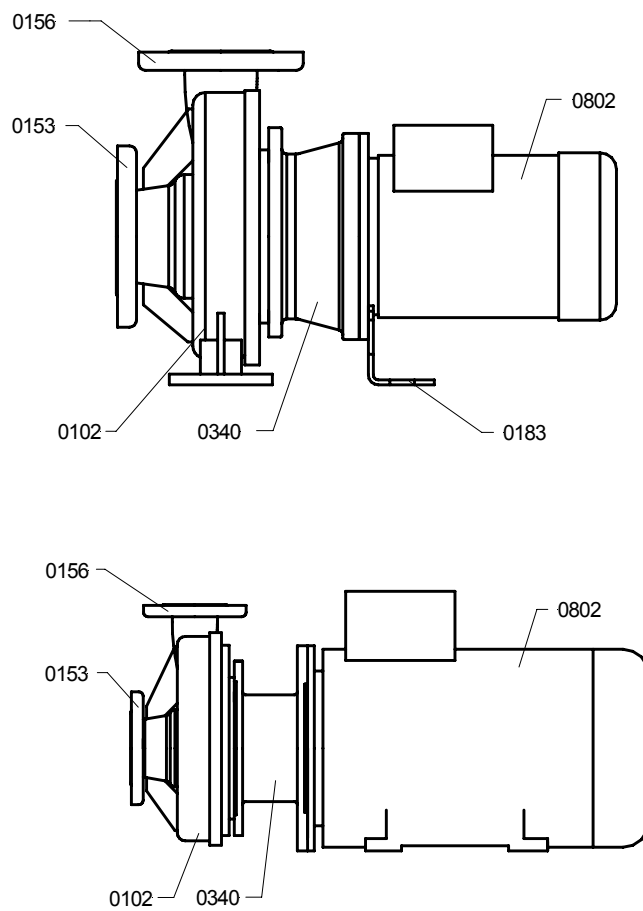

Fig. 3 Overview

- top: up to motor size 112
- below: up to motor size 132
- 0102 - volute casing
- 0153 - suction branch
- 0156 - discharge branch
- 0183 - support foot
- 0340 - lantern
- 0802 - motor

Product description

3.2 Description

The pump is a single-stage end-suction centrifugal pump with main dimensions and characteristic according to DIN EN 733 resp. DIN EN 22858.

3.2.1 Areas of application

Standard design

Pumps of the standard design are used for:

- industrial application
- textile technology
- surface treatment for environmental technologies
- all systems and processes involved in the food product, dairy, and beverage industries

3.3 Proper usage

WARNING



Improper usage!

- ▲ Death, serious bodily injury, damage to property.
 - ▷ Pump only media that are specified in the order. The pump has been specially designed for that purpose.
 - ▷ Operate the pump only in the electrical network specified in the order.
-

3.3.1 Pumped liquids

Only pure or slightly contaminated liquids with a maximum particle size of 0.4 mm may be pumped. These liquids may not chemically or mechanically attack the pump materials or lower their strength. If liquids with a viscosity greater than that of water are to be pumped, make sure that the motor will not be overloaded. The pump may not be operated beyond the maximum allowable values. Even short periods of pressure overload (e.g., as a result of a pressure surge) should be avoided.

3.3.2 Minimum flow rate Q_{\min}

Do not operate the pump below minimum flow rate of $Q_{\min} = 10 - 15 \% Q_{\text{opt}}$.

3.3.3 Connections and pipelines

The nominal diameters of the system pipelines should be equal to or greater than the nominal diameters of the pump, i.e., DNE (suction side) and DNA (pressure side), and the connecting elements to the pump must conform exactly to the design standard/specification of the mating connector piece installed on the pump. The suction line must be absolutely leak-tight and laid in such a way that no air pockets can form. Avoid tight elbows and do not install valves immediately upstream of the pump. The suction head of the system may not be greater than the suction head guaranteed by the pump.

3.3.4 Motor activation

Do not start and stop the motor more than 15 times per hour.

3.3.5 Design

All information and descriptions in this Operating Manual concerning the use and operation of the pumps are based exclusively on the standard designs.

These rules do not apply to special designs, to customer specific modifications, or to random external influences which

may occur during use and operation.

3.4 Technical data

WARNING



Overloading the pump!

- ▲ Death, serious bodily injury, damage to property.
- ▷ Use the pump only under the indicated operating conditions.
- ▷ Also avoid short over pressure situation (e.g. caused by pressure surge).

3.4.1 Pump denomination

The HILGE pump denomination is structured as shown below:

MAXA	80-160	L	100/80	15	2
pump type					
size					
design					
nominal diameter DN _s / DN _D					
power [kW]					
number of poles					

Tab. 1 HILGE pump denomination (example)

3.4.2 Pump serial number

The pump can be identified by the pump serial number. When ordering spare parts give always the pump serial number.

Pump serial number (example) 223 / 09 / 1248

The pump serial number includes:

- pump type (201 - MAXANA, 223 - MAXA)
- year of manufacture (09)
- reg. number (1248)

Product description

3.4.3 Nameplate

The name plate contains the following information:

- pump type
- pump serial number
- capacity Q
- head H
- motor power P
- drive speed n
- number of operating manual

3.4.4 Performance data

The performance data of the pump, namely, its head and delivery rate, are determined in accordance with DIN EN ISO 9906 - appendix A, class 2 and are documented on the acceptance records.

3.5 Weights

Design features of the described standard pumps:

Caution:

The weights can - depending on design and accessories - differ from those presented. The manufacturer gives you when given the pump / order number precise information.

- Motor foot mounting
- Single mechanical seal
- SIEMENS motor

Pump size	P2 [kW]	IEC size	DNs	DNd	Net weight [kg]
80-160	11,0	160M	100(125,150)	80(100)	118
80-160	15,0	160M	100(125,150)	80(100)	131
80-160	18,5	160L	100(125,150)	80(100)	148
80-160	22,0	180M	100(125,150)	80(100)	164
80-200	15,0	160M	100(125,150)	80(100)	166
80-200	18,5	160L	100(125,150)	80(100)	183
80-200	22,0	180M	100(125,150)	80(100)	199
80-200	30,0	200L	100(125,150)	80(100)	249
80-200	37,0	200L	100(125,150)	80(100)	272
80-250	30,0	200L	100(125,150)	80(100)	264
80-250	37,0	200L	100(125,150)	80(100)	287
100-200	18,5	160L	125(150)	100(125)	196
100-200	22,0	180M	125(150)	100(125)	212
100-200	30,0	200L	125(150)	100(125)	262
100-200	37,0	200L	125(150)	100(125)	285

Tab. 3 Weights MAXA-L 2 pole

Pump size	P2 [kW]	IEC size	DNs	DNd	Net weight [kg]
80-160	3,0	100L	100(125,150)	80(100)	77
80-160	4,0	112M	100(125,150)	80(100)	82
80-200	5,5	132S	100(125,150)	80(100)	116
80-200	7,5	132M	100(125,150)	80(100)	129
80-250	5,5	132S	100(125,150)	80(100)	123
80-250	7,5	132M	100(125,150)	80(100)	136
80-250	11,0	160M	100(125,150)	80(100)	163
80-315	5,5	132S	100(125,150)	80(100)	136
80-315	7,5	132M	100(125,150)	80(100)	149
80-315	11,0	160M	100(125,150)	80(100)	176
80-315	15,0	160L	100(125,150)	80(100)	193
80-315	18,5	180M	100(125,150)	80(100)	267
80-315	22,0	180L	100(125,150)	80(100)	282
100-200	5,5	132S	125(150)	100(125)	123
100-200	7,5	132M	125(150)	100(125)	136
100-250	5,5	132S	125(150)	100(125)	131

Tab. 4 Weights MAXA-L 4 pole

Product description

Pump size	P2 [kW]	IEC size	DNs	DNd	Net weight [kg]
100-250	7,5	132M	125(150)	100(125)	144
100-250	11,0	160M	125(150)	100(125)	171
100-250	15,0	160L	125(150)	100(125)	188
125-250	7,5	132M	150(200)	125(150)	160
125-250	11,0	160M	150(200)	125(150)	187
125-250	15,0	160L	150(200)	125(150)	204
125-250	18,5	180M	150(200)	125(150)	278
125-250	22,0	180L	150(200)	125(150)	293

Tab. 4 Weights MAXA-L 4 pole

Pump size	DNs	DNd	P2 [kW]	IEC size	Net weight [kg]
40-200	65	40	3	100L	70
50-160	80	65	7,5	132S	81
65-125	100	65	5,5	132S	78
65-200	80	65	11	160M	110
65-200	80	80	15	160M	144
65-250	80	65	5,5	132S	124
65-250	80	65	15	160M	153
65-250	80	80	18,5	160L	227
65-250	80	80	22	180M	242
65-250	80	80	30	200L	308,3
65-250	80	80	37	200L	317

Tab. 5 Weights MAXANA L

3.5.1 Noise emissions

Measured values according to DIN EN ISO 3746 for pump units; uncertainty of measurement 3dB (A).

Motor power kW	L _{pfa} [dB (A)]
2,2	67
3	73
4	73
5,5	73
7,5	75
11	75
15	76
18,5	76
22	75
30	77
37	77
45	78
55	78
75	79
90	79

Tab. 6 Noise emissions MAXA 2-pole

Motor power kW	L _{pfa} [dB (A)]
3	63
4	63
5,5	63
7,5	72
11	72
15	76
18,5	76
22	75
30	75
37	76
45	76
55	75
75	80
90	80
110	80

Tab. 7 Noise emissions MAXA 4-pole

Product description

	Motor power kW	L _{pfa} [dB (A)]	Number of pols
MAXANA	0,75	57	2
	1,1	57	
	1,5	61	
	2,2	61	
	3	67	
	4	68	
	5,5	73	
	7,5	73	
	11	75	
	15	75	
	18,5	75	
	22	72	
	30	78	
	37	78	
	45	78	
55	79		

Tab. 8 Noise emissions MAXANA 2-pole

	Motor power kW	L _{pfa} [dB (A)]	Number of pols
MAXANA	0,55	52	4
	0,75	52	
	1,1	55	
	1,5	55	
	2,2	61	
	3	61	
	4	61	
	5,5	70	
	7,5	70	

Tab. 9 Noise emissions MAXANA 4-pole

Noise emissions caused by a pump are significantly affected by its application and construction. For this reason, no guarantee of accuracy is given for the values indicated here.

3.5.2 Maximum operating temperatures

CAUTION



Exceeding the max. permitted operating temperature!

- ▲ Death, serious bodily injury, damage to property.
- ▷ Never exceed the specified operating temperatures!

Tab.10 lists the maximum permissible temperatures.

Design	Temp. [°C]
Standard design	95
Special design	150
Sterilisation	140

Tab. 10 Operating temperatures

3.5.3 Maximum operating pressure

WARNING



Pressure overload!

- ▲ Death, serious bodily injury, damage to property.
- ▷ The pump must be operated according to the order data.
- ▷ Never exceed the specified maximum operating pressures.

Pump operating pressure

The maximum permitted operating pressure depends on various factors:

- pump type
- design of connections
- design of mechanical seal.

For the values that apply to your pump, please refer to the order documents.

4. Mounting, installation and connection

Overview

This chapter is intended for the maintenance and repair personnel.

This section describes how to mount, adjust and install the pump. You get to know what to consider when you connect the pump to the electric mains supply and how to improve the flow in order to avoid dry running of the shaft seals.

4.1 Inspection before pump installation

4.1.1 Check failure-free running of the impeller

Check the failure-free impeller running in this way:

1. Remove motor shroud¹.
2. Remove fan cover of motor.
3. Consider direction of rotation (arrow).
4. Rotate shaft slowly by hand via the fan.

The shaft must rotate easily. If the impeller rubs against the pump casing (for example due to transport damage) it has been damaged.

When the impeller rubs against the casing: Contact HILGE Service.

When the impeller runs failure free:

5. Re-fit fan cover of the motor.
6. Re-fit motor shroud¹.

4.2 Set-up and alignment of the pump assembly

WARNING



Misalignment of the pump due to an improper foundation!

- ▲ Death, serious bodily injury, damage to property.
- ▷ Ensure that the foundation on which the pump is set up is clean and flat and has sufficient load capacity.
- ▷ Mount the pump – especially when it is to be set up vertically – with the use of suitable heavy-duty anchors. As the centre of gravity is higher, the pump can tip.
- ▷ The mounting points provided must be bolted to the foundation according to the standard rules of mechanical engineering to ensure the satisfactory set-up of the pump.

WARNING



Short circuit!

- ▲ Death, serious bodily injury, damage to property.
- ▷ In case of a vertical installation: Under no circumstances the motor should be positioned underneath the pump. If there is leakage the motor could be damaged.

1. SUPER design only.

Align the pump in this way:

1. Use an engineer's spirit level laid across the machined surface of the discharge branch connection to align the assembly.
2. After aligning the assembly, tighten the mounting bolts uniformly in a crosswise manner.

4.3 Installation in the pipeline

WARNING



Mechanical overload!

- ▲ Death, bodily injury or damage to property.
 - ▷ Do not use the pump or its connecting sleeves to support the pipeline. (EN809 5.2.1.2.3 and EN ISO 14847).
 - ▷ In addition to the general rules of machine-building and plant construction, also follow the instructions provided by the manufacturer of the connecting elements used (e.g., flanges) when installing the pump in the pipeline or plant. These specifications will contain data on torques, maximum allowable angular offset and tools / auxiliary materials to be used.
 - ▷ After connecting the pipes, check the alignment of the coupling¹.
 - ▷ It is absolutely necessary to avoid twisting the pump.
-

ATTENTION

Mechanical overload due to foreign objects!

- ▲ Damage to property.
 - ▷ The suction and delivery ports are sealed with sheets of plastic, the flushing and drain lines with plastic caps. These must be removed before the pump is installed in the system.
-

Details about dry running

What is dry running?

To seal the pump shaft against the pump casing the mechanical seal needs lubrication between its rotating faces.

This lubrication is provided by the pumped liquid. If the pump is fitted with a quench the lubrication for the quench must be provided from an external source.

Dry running occurs when the lubrication fails. Dry running destroys the mechanical seal in few seconds.

1. For base plate design (CN) only

Mounting, installation and connection

For example see Fig. 5.

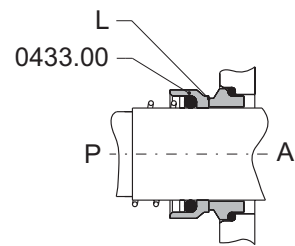

K.0075V2

Fig. 5 Lubrication between slide surfaces

- P - pump side
- 0433.00 - mechanical seal
- L - lubrication
- A - atmosphere side

CAUTION



Dry running!

▲ Damage to property.

- ▷ The suction line must be absolutely leak proof and laid in such a way that no air pockets can form.
- ▷ Avoid tight elbows and valves immediately upstream of the pump. They interfere with the incoming flow to the pump and thus with the NPSH of the system.
- ▷ The head of the system may not be greater than the head guaranteed by the pump.
- ▷ The head of the system may not be greater than the head guaranteed by the pump.
- ▷ The nominal pipeline diameters of the system should be equal to or greater than the DNS or DND connectors of the pump.
- ▷ A foot valve should be used in suction mode.
- ▷ To prevent air pockets from forming, the suction line must be laid so that it rises to the pump; a gravity feed line must be laid with a slight downward gradient to the pump.
- ▷ If local conditions do not allow the suction line to ascend continuously, install a venting device at the highest point of the line.
- ▷ A shut off valve should be installed in the suction line near the pump. This valve must be completely open during operation and may never be used as a control valve.
- ▷ A shut off valve should be installed in the discharge line, near the pump, to control the delivery rate.

Mounting, installation and connection

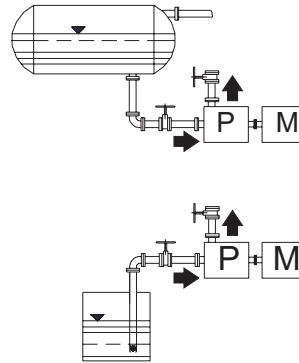

K.0076/2

Fig. 6 Installation in the pipeline

above: gravity feed mode
 below: suction mode
 P - pump
 M - motor

4.3.1 Space requirements

ATTENTION

Overheating!

- ▲ Damage to property.
- ▷ Ensure sufficient ventilation.
- ▷ Make sure not to re absorb warm cooling air. Consider other heat sources in the area.

Pay attention to motor power. Keep the minimum distances.

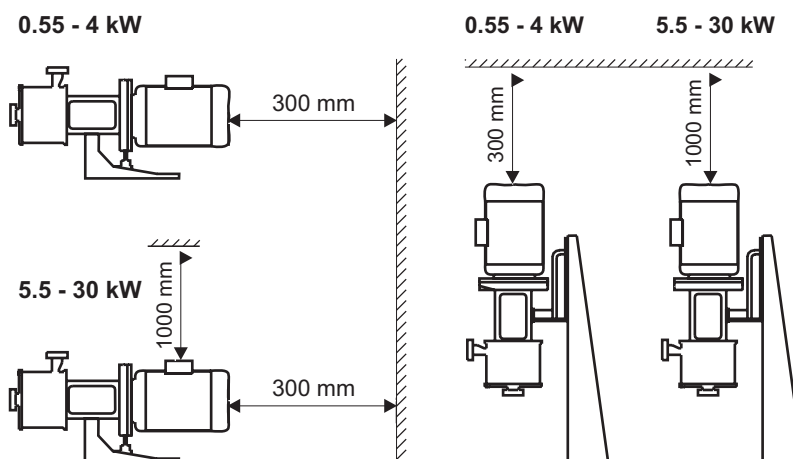

K.0317V1

Fig. 7 Minimum distances

Mounting, installation and connection

4.3.2 Reduction of noise and vibration

Noise and vibration are generated by the pulsating flow of the rotors and by the flow in pipes and fittings. The effect on the environment is subjective and depends on correct installation and the state of the remaining system. One way of reducing noise and vibrations is by installing expansion joints.

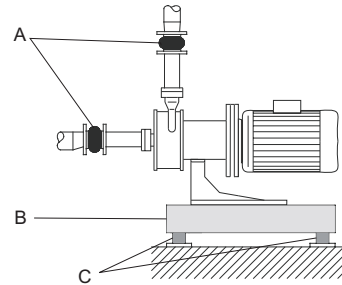

K.0346V1

Fig. 8 Expansion

- A - Expansion joints
- B - Foundation
- C - vibration absorber

Function of expansion joints:

- Absorbability of expansions/contractions in the pipework caused by changing the temperature of the pumped medium.
- Reduction of mechanical strains in connection with pressure surges in the pipework.
- Insulation of mechanical structure-borne noise in the pipework (only rubber bellows expansion joints).



Do not install expansion joints to compensate for inaccuracies in the pipework such as centre displacement of flanges. Fit expansion joints at a distance of minimum 1 to 1½ times the nominal flange diameter away from the pump on the suction as well as on the discharge side. This will prevent the development of turbulence in the expansion joints, resulting in better suction conditions and a minimum pressure loss on the pressure side. At high viscosity or velocities, we recommend you to install larger expansion joints corresponding to the pipework.

Mounting, installation and connection

4.4 Connections

4.4.1 Flushing connection for the single mechanical seal

HILGE pumps with single-chamber mechanical seals are equipped with a seal cartridge.

The flushing liquid is located in this seal cartridge. It passes over into the liquid pumped via a throttle gap (lost flush).

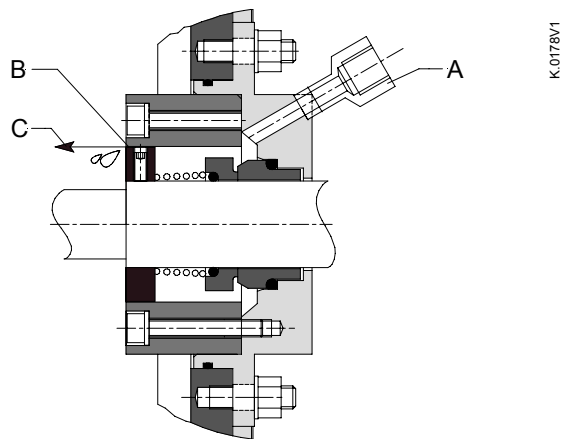

Fig. 9 Flushing connection

- A - flushing connection
- B - throttle gap
- C - flushing media passes over into the pumped liquid

CAUTION



Dry running!

- ▲ Damage of property.
- ▷ Connect the lines of the flushing system in that way that a liquid supply is guaranteed.
- ▷ Always keep the fill level in the liquid pot between the upper and lower marks.
- ▷ Make certain the barrier pressure is 1.5 - 2 bar above the operating pressure.

Connect the flush in this way:

1. Connect line A.
2. Check tightness of connection.

Mounting, installation and connection

4.4.2 Flushing connection for double mechanical seal

4.4.2.1 Double mechanical seal

HILGE pumps with double mechanical seal are equipped with a seal cartridge.

Depending on the seal design the barrier or flushing fluid flows inside this seal cartridge.

The connection must be carry out as shown in Fig. 10. So you can ensure that the fluid can flush the mechanical seal effectively.

The connections (A and B) run vertical through the openings of the lantern 0340.00.

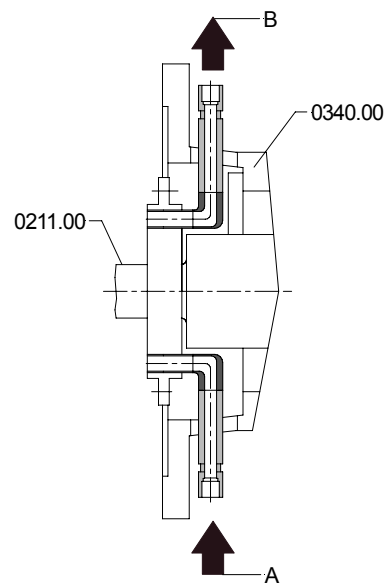

K.0179V1

Fig. 10 Connection for flush

- A - inlet for flushing liquid
- 0211.00 - pump shaft
- B - drain for flushing liquid
- 0340.00 - lantern

CAUTION



Dry running!

- ▲ Damage of property.
- ▷ Connect the lines of the flushing system in that way that a liquid supply is guaranteed.
- ▷ Always keep the fill level in the liquid pot between the upper and lower marks.

Connect the flush in this way:

1. Connect inlet line A
2. Connect drain line B
3. Check tightness of connection

Mounting, installation and connection

4.4.2.2 Double mechanical seal - tandem arrangement

Flushing liquid In order to continue functioning, the mechanical seals require a flushing liquid, some of its purposes being:

- Preventing leaks
- Dry-run protection
- Lubrication and cooling of the mechanical seals
- cutting off the air from substances which react unfavourably with oxygen

A pure liquid, compatible with the pumped liquid, serves as a flushing liquid.

Ensure the functioning in this way:

1. Open feed (inlet) line for flushing liquid
2. Bleed seal cartridge
3. Ensure unpressurised circulation

A pure liquid, compatible with the pumped liquid, serves as a flushing liquid.

In case of abrasive media provide a "lost" flushing, i.e. where the flushing liquid is discharged directly.

4.5 Electrical connections

WARNING



Electric shock!

- ▲ Death, serious bodily injury.
- ▷ The electrical connections must be made by a qualified electrician.
- ▷ VDE specifications and any local regulations must be followed, especially those pertaining to safety measures.

WARNING



Capacity overload!

- ▲ Death, serious bodily injury, damage to property.
 - ▷ Check the voltage stated on the rating plate of the motor against the operating voltage!
 - ▷ Install an electrical circuit breaker.
-

Mounting, installation and connection

4.5.1 Star connection

Star-connection 3-phase system for high voltage.

Connect the pump as specified in the order documents. The figure below shows the scheme for star connection.

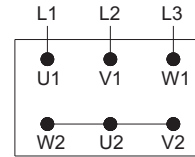

K.0079V1

Fig. 11 Star connection

4.5.2 Delta connection

Delta-connection for low voltage.

Connect the pump as specified in the order documents. The figure below shows the scheme for delta-connection.

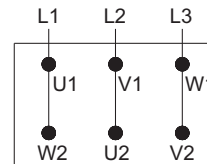

K.0080V1

Fig. 12 Delta connection

4.5.3 Checking the direction of rotation after connection

ATTENTION

Danger of dry running!

▲ Damage to property.

- ▷ Before checking of the direction of rotation: Fill and vent the pump.
- ▷ Connect the motor and briefly (for about 2 seconds) check the direction of rotation.
Note the directional arrow (red) on the pump. If the pump is turning in the wrong direction the mechanical seal can be destroyed.

Check the rotating direction in this way:

1. After electrical connection: Mount all safety equipment again.
2. Check tightness of hydraulic connection.
3. Fill pump (plant).
4. Observe arrow of rotation.
5. Switch on motor short-time (1-2 seconds).
6. Compare directions (motor / arrow).
7. Correct connection if need be.

Operation with frequency inverter

See documentation of manufacturer.

5. Start-up / shut-down

Overview

This section describes how to start up and shut down the pump. You get to know which inspections contribute to failure-free operation and increased life of the pump.

5.1 Start-up

5.1.1 Check application conditions

Check the application conditions of the pump in this way:

1. Compare the data of the following documents with the provided application condition of the pump:
 - purchasing documents (confirmation of the order)
 - nameplate
 - operating manual.
2. Make sure that the pump will operate under the mentioned conditions only. This conditions apply to (e. g.) pressure, temperature, liquid pumped.

5.1.2 Starting up the pump

Start up the pump in this way:

1. Check tightness of connection.
2. Make sure that all safety equipment is installed.
3. Make sure that all electrical connections are correct.
4. Open the check valves in the system.
5. Fill the pump together with the system.
6. Vent the pump and system.
7. Fully open the check valve on the suction side.
8. Close the check valve on the discharge side.
9. Start the pump.
10. Slowly open the check valve on discharge side.

CAUTION



Overheating and pressure overloading!

- ▲ Damage to property.
 - ▷ Never operate the pump against a closed shut-off device. Operation with a shut-off device must on no account continue for longer than 30 seconds.
-

If delivery head does not rise after the pump has been turned on:

1. Switch off the pump.
2. Vent the pump (system) again.
3. Repeat steps 7., page 30 to 10., page 30.

5.1.3 Functional check of the mechanical seal

Check the function of the mechanical seal in this way:

1. Watch the pump and check the mechanical seal for flawless functioning (leak test).
An intact mechanical seal works virtually without leakage.

If liquid pumped or flushing liquid leak:

1. Switch off the pump.
2. Renew the mechanical seal.
Observe section 6.5.5

Start-up / shut-down

5.2 Shut-down

5.2.1 Shutting down the pump

CAUTION**Pressure surge!**

- ▲ Death, serious bodily injury, damage to property.
 - ▷ Always close shut-off devices slowly!
-

What is a pressure surge?

A pressure surge is an abruptly pressure increasing in the system. This pressure increasing can - for example - be caused by a quick blocking of the flow in the discharge pipe. In case of a pressure surge the maximum permitted pump pressure is temporarily exceeded manifold.

Shut down the pump in this way:

1. Close the check valve on the discharge side.
2. Switch off the pump.
3. Close the check valve on the suction side.
4. Switch off the flushing system¹.
5. Make sure that the pump is depressurised.
6. Switch off pressure in barrier system².

5.2.2 Cleaning the pump after shut-down

CAUTION**Jamming!**

- ▲ Damage to property.
 - ▷ Clean the pump appropriately after shut down.
-

See section ("Cleaning" on page 11)

1. only for double mechanical seal or quench design
2. only for back-to-back arrangement

6. Maintenance / servicing

Overview

This chapter is intended for the maintenance and repair personnel.

This section gives important information concerning maintenance and servicing of the pump. Read this section before you carry out maintenance work or troubleshooting measures!

6.1 Safety instructions for maintenance, inspection and installation work

WARNING



Unprofessional work!

- ▲ Death, bodily injury, damage to property.
- ▷ The operator must ensure that all maintenance, inspection, and installation work is carried out by authorised and qualified technical personnel, who have acquired the required knowledge through study of the operating instructions.

DANGER



Electrical shock if electrical parts are touched!

- ▲ Death, bodily injury.
- ▷ Always turn off the electrical supply at the pump before eliminating any breakdown.

WARNING



Pressurized spray!

- ▲ Death, bodily injury, damage to property.
- ▷ Depressurize the pump before eliminating any breakdown.

WARNING



Hot components!

- ▲ Death, bodily injury, damage to property.
- ▷ Always allow to cool down before eliminating any breakdown.

WARNING



Unintentioned switching on the pump!

- ▲ Death, bodily injury, damage to property.
- ▷ Take appropriate measures to ensure that the machine cannot be unintentionally turned on again.

WARNING



Contact or inhaling of hazardous substances!

- ▲ Death, bodily injury, damage to property.
- ▷ Pumps or systems which convey hazardous media must be decontaminated.

WARNING**Missing protection and safety equipment!**

- ▲ Death, bodily injury, damage to property.
 - ▷ Immediately after completing the work install the protection and safety equipment and make sure it functions.
-

CAUTION**Improper tools!**

- ▲ Damage to property.
 - ▷ In accordance with the design standard (3A0.01 to 3A3.37), all tools, possible support surfaces, and other auxiliary materials must ensure that all parts of the pump can be assembled without damage (e.g. scratches). See (HILGE assembly tool kit) on page 49
-

CAUTION**Frost!**

- ▲ Damage to property.
 - ▷ When there is danger of frost drain the pump completely.
-

6.2 Maintenance of the pump

The pump is a low-maintenance pump. In addition to cleaning, the only point to be kept in mind is the wear to the rotating mechanical seal.

6.3 Maintenance of the motor

See operating manual of the motor manufacturer.

6.4 Maintenance of L bearing

6.4.1 Design L bearing

Bearing

The bearing consists of a grooved ball bearing 0321.00. This bearing can absorb radial forces.

6.4.1.1 Grease quantities for roller bearings during assembly

The hollow areas between the cylinder bodies are filled in the factory 30% - 50% with grease. This grease filling is sufficient for operation of the bearing under conditions normally encountered.

6.4.2 Bearing replacement

To ensure problem-free operation of the pump, replace the bearing after about 15,000 to 20,000 hours of operation.

6.4.2.1 Premature bearing replacement

If persistent external conditions such as dust, splashed water, aggressive ambient air, or high temperatures promote wear, bearings should be replaced after about 5000 hours of operation.

6.4.3 Bearing lubrication

6.4.3.1 Cylinder bearing greases

Use only the cylinder bearing greases listed here or demonstrably comparable ones to lubricate the roller bearings.

Manufacturer	Bearing temperature $\leq 120\text{ }^{\circ}\text{C}$	Bearing temperature $\leq 60\text{ }^{\circ}\text{C}$ – Danger of water entering
ARAL	HL 3	FM 3
BP	BP ENERGREASE LS 3	ENERGREASE PR 3 ENERGREASE LS 3
CALTEX	CALTEX MULTIFAK 2	CALTEX CUP GREASE 3 CALTEX MULTIFAK 2
ESSO	BEACON 3	ESTAN 2 R BEACON 3
GULF	GULFCROWN GREASE No. 2 GULFCROWN GREASE No. 3	GULFCROWN GREASE No. 2 GULFCROWN GREASE No. 3
MOBIL - OIL	MOBILUX GREASE No. 3	GARGOYLE GREASE B No. 3 MOBILUX GREASE No. 3
SHELL	SHELL ALVANIA GREASE 3	SHELL UNEDO GREASE 3 SHELL ALVANIA GREASE 3
VALVOLINE	VALVOLINE LB 2	VALVOLINE LB 2
OKS	OKS 4200 ($\leq 200\text{ }^{\circ}\text{C}$)	
SKF	LGMT 3/1	LGMT 3/1

Tab. 11 Cylinder bearing greases

Maintenance / servicing

6.4.4 Re lubrication L-bearing

Lubricate the roller bearings in accordance to the table below. The mentioned data apply to normal operating conditions.

CAUTION



Faulty lubrication of the roller bearings!

- ▲ Damage to property.
- ▷ Do not use a higher quantity of grease to lubricate the bearings as per description!

Lantern	Motor size	Re lubrication period [h] at 1450 min-1	Re lubrication period [h] at 2900 min-1	Re lubrication period [h] at 3600 min-1	Re lubrication [g]
360/200	80	20000	12000	7000	5
360/200	90	20000	12000	7000	5
360/250	100	20000	12000	7000	5
360/250	112	20000	12000	7000	5
360/300	132	15000	8000	6000	7
470/300	132	15000	8000	6000	7
360/350	160	12000	6000	4000	10
470/350	160	12000	6000	4000	10
360/350	180	12000	6000	4000	10
470/350	180	12000	6000	4000	10
470/400	200	11000	5000	3500	13

Tab. 12 Re lubrication, 3 - 37 kW

Lantern	Motor size	Re lubrication period [h] at 1450 min-1	Re lubrication period [h] at 2900 min-1	Re lubrication period [h] at 3600 min-1	Re lubrication [g]
470/450	225	10000	5000	3500	30
470/550	225	10000	5000	3500	30

Tab. 13 Re lubrication, 44 - 55 kW

6.5 Assembly / Disassembly

6.5.1 Parts overview

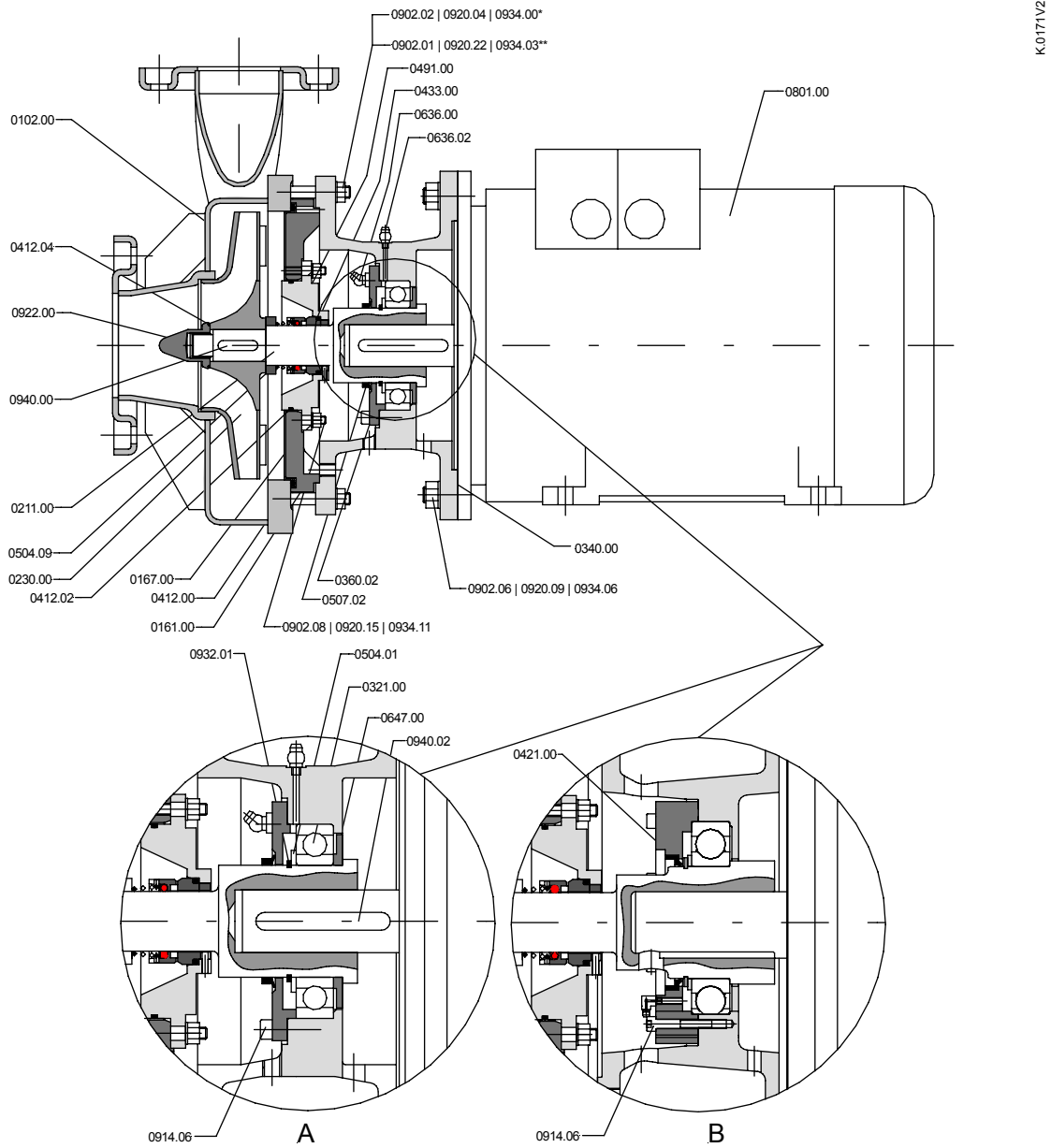

Fig. 13 Parts overview

- A - up to 37 kW
- B - 45 / 55 kW
- *Size 250
- **Size 315 and above

Maintenance / servicing

Qty.	Part No.	Description
1	0102.00	volute casing
1	0161.00	backplate
1	0167.00	casing backplate liner
1	0211.00	pump shaft
1	0230.00	impeller
1	0321.00	grooved ball bearing
1	0340.00	lantern
1	0360.02	bearing cover
1	0412.00	O-Ring
1	0412.02	O-Ring
4	0412.03	O-Ring
1	0412.04	O-Ring
1	0421.00	lip seal
1	0433.00	mechanical seal
1	0433.01	mechanical seal
1	0471.00	seal cover
1	0491.00	seal cartridge
1	0504.01	spacer ring
1	0504.09	spacer ring
1	0507.02	deflector / V-ring
1	0516.01	locating ring
1	0636.00	grease nipple
1	0636.02	grease nipple
1	0647.00	grease regulator

Qty.	Part No.	Description
1	0801.00	flanged motor
12	0902.01	stud
8	0902.02	stud
8	0902.06	stud
8	0902.08	stud
4	0904.06	grub screw
1	0904.12	grub screw
4	0914.06	socket head cap screw
3	0914.09	socket head cap screw
4	0918.00	hexagon head sterile screw
8	0920.04	hexagon nut
8	0920.09	hexagon nut
8	0920.15	hexagon nut
12	0920.22	hexagon nut
1	0922.00	impeller nut
1	0930.00	Nord-Lock washer
1	0932.01	circlip
8	0934.00	spring washer
12	0934.03	spring washer
8	0934.06	spring washer
8	0934.11	spring washer
3	0934.23	spring washer
1	0940.00	key
1	0940.02	key

Tab. 14 Parts list

6.5.2 Instructions for disassembly

DANGER



Disregarding important instructions!

- ▲ Death, serious bodily injury, damage to property.
- ▷ Before you disassemble the pump note section 6.1.

ATTENTION

Important aspects!

- ▲ Damage to property.
- ▷ Use tools from HILGE assembly tool kit in order to disassemble the pump without damage and scratches.

6.5.3 Instructions for assembly

DANGER



Disregarding important instructions!

- ▲ Death, serious bodily injury, damage to property.
- ▷ Before you maintenance or assemble the pump note section 6.1.

Important aspects!

- ▷ Use tools from HILGE assembly tool kit in order to assemble the pump without damages and scratches.
- ▷ To guarantee a good seal, use only O-ring seals with the original dimensions.
- ▷ Never use grease which contains mineral oil when assembling the wet end parts¹.
- ▷ Replace mechanical seals always in complete assembly.
- ▷ As the impeller nut is being fitted, it must be possible to feel the self-locking action². It must be possible to tighten the nut without any problems. Tighten manually for the first two turns, so that the thread insert sits correctly on the shaft.
- ▷ To tighten impeller nut 0922.00, use either a screw device or the impeller nut installing device because the torque applied to tighten must be absolutely concentric. Otherwise there is the danger that the pump shaft 0211.00 will be bent.

6.5.4 Assembly of MAXA-L

How to assemble the MAXA-L:

Please note Unless specially noted in individual cases, the part numbers given in the following instructions may be found in tab. 14.

Compare the description with fig. 13.

1. Push the grease regulator 0647.00 onto plug-in-shaft 0211.00. The grease regulator is a disk that limits the amount of grease.	2. Grease the grooved ball bearing 0321.00. For grease quantities, see Tabelle 12.
3. Press the grooved ball bearing 0321.00 onto the plug-in-shaft 0211.00.	4. Assemble spacer ring 0504.01.
5. Assemble circlip 0932.01.	6. Push plug-in-shaft 0211.00 into the bearing housing 0340.00.
7. Assemble the bearing cover 0360.00.	8. Assemble V-ring 0507.02.
9. Insert key 0940.02 into the motor shaft.	10. Grease the motor shaft stub. Use suitable grease to do this ^a .
11. Push the mounted lantern 0340.00 onto the motor shaft. The lantern 0340.00 must be aligned as follows: With single mechanical seal, the leakage discharge is on the bottom. With a double mechanical seal, there are rinsing connections on the top and bottom (through the window in the lantern).	The rest of the assembly process depends on the type of mechanical seal. An overview of different types of mechanical seals may be found on page 39. For the remaining assembly steps, please read 6.5.5 to 6.5.11.

a. Klüber paste UH1 84-201, assembly tool kit auxiliary material No. 6

1. Parts which come in contact with the pumped medium.
2. Only apply to impeller nut with Helicoil thread insert.

6.5.5 Overview mechanical seal Arrangements

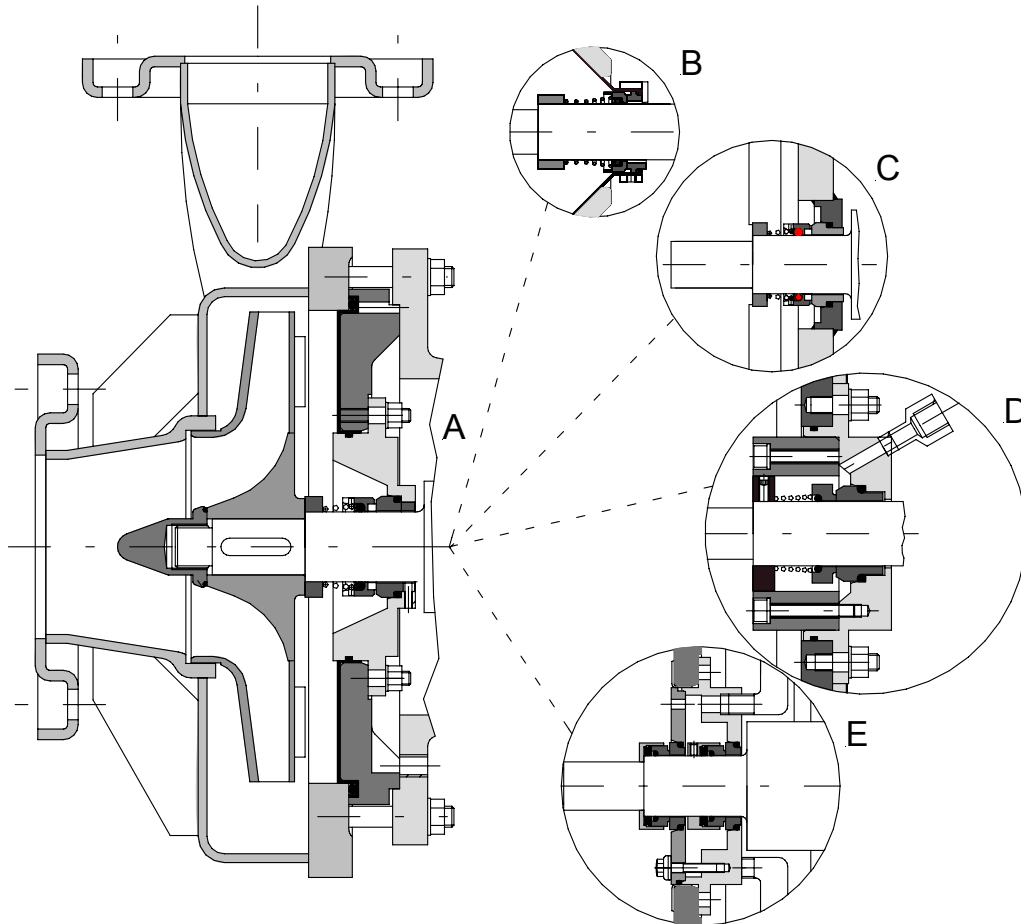

K.0172/1

Fig. 14 Mechanical seal arrangements

Variant	Seal type	Characteristic	Page
A	Single mechanical seal	Seat located in casing backplate liner	40
B	Single mechanical seal	Seat located in sealing seal cartridge - with casing backplate liner	41
C	Single mechanical seal	Seat located in backplate, solid	42
D	Single mechanical seal	Seat located in sealing seal cartridge, mechanical seal flushed	43
E	Double mechanical seal	Mechanical seal in tandem-arrangement	44

Tab. 15 Overview mechanical seal arrangement

6.5.6 Assembly of the single mechanical seal (A)

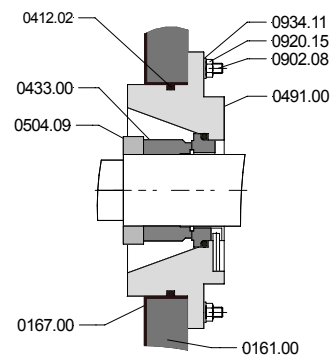

K 0151V1

Fig. 15 Single mechanical seal (A)

Features of the mechanical seal

- Single mechanical seal
- Seat in seal cartridge 0491.00
- With casing backplate liner 0167.00

Assemble the mechanical seal in this way:

Please note The part numbers given in the following instructions may be found in tab. 14.

The assembly aids listed here may be found on page 49.

1. Insert the casing backplate liner 0167.00 into the backplate 0161.00.	2. Insert the O-ring 0412.02 into the seal cartridge 0491.00.
3. Push mechanical seal cartridge 0491.00 into backplate 0161.00.	4. Fasten seal cartridge 0491.00 on the backplate 0161.00. Use spring washers 0934.11 and hexagon nut 0920.15 to do this. Tighten to 18 Nm (M8).
5. Grease the centring between the backplate 0161.00 and the lantern 0340.00. Use Klüberpaste UH1 84-201 from HILGE Assembly Tool Kit to do this (Pos. 6, fig. 35).	6. Fasten backplate 0161.00 with seal cartridge 0491.00 installed on the lantern 0340.00. See fig. 13, page 36.
Push the assembly sleeve from HILGE Assembly Tool Kit (Pos. 3, fig. 35) onto the shaft 0211.00.	7. Spray the assembly sleeve with clean water. Use spray bottle from HILGE Assembly Tool Kit (Pos. 2, fig. 35).
8. Push the stationary ring of the mechanical seal 0433.00 into the seat. Use the installation sleeve from HILGE Assembly Tool Kit to do this (pos. 12, fig. 35).	9. Push the rotating ring of the mechanical seal 0433.00 onto the shaft 0211.00 and up to the stop. Use the assembly sleeve from HILGE Assembly Tool Kit (pos. 12, fig. 35) to do this.
10. Push the spacing ring 0504.09 onto the shaft 0211.00.	11. Pull the assembly sleeve off the shaft 0211.00.

For assembling the impeller and volute casing read on at section 6.5.11, page 45 .

6.5.7 Assembly of the single mechanical seal (B)

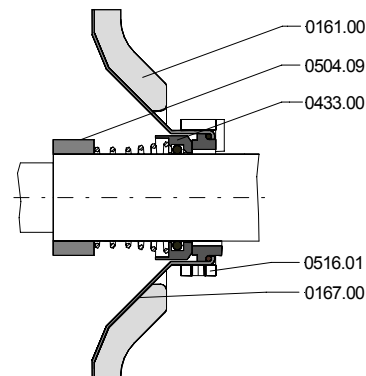

K.0140V1

Fig. 16 Single mechanical seal (B)

Features of the mechanical seal

- Single mechanical seal
- Seat in casing backplate liner 0167.00

Assemble the mechanical seal in this way:

Please note

The part numbers given in the following instructions may be found in tab. 14.

The assembly aids listed here may be found on page 49.

1. Insert the casing backplate liner 0167.00 into backplate 0161.00.	2. Assemble locating ring 0516.01 onto the casing backplate liner 0167.00 (only for mechanical seal with lock against rotation).
3. Grease the centring between the backplate 0161.00 and the lantern 0340.00 ^a . Use Klüberpaste UH1 84-201 from HILGE Assembly Tool Kit to do this (Pos. 6, fig. 35).	4. Fasten backplate 0161.00 with the casing backplate liner 0167.00 inserted onto the lantern 0340.00. See fig. 13, page 36.
5. Push the assembly sleeve ^{b,c} onto shaft 0211.00 up to the stop.	6. Spray the assembly sleeve and shaft 0211.00 with clean water. Use spray bottle from HILGE assembly tool kit (pos. 2, fig. 35).
7. Push the fixed part of the mechanical seal 0433.00 over the assembly sleeve into the seat. Use the assembly sleeve to do this. ^{d,e}	8. Push the rotating part of mechanical seal 0433.00 onto the shaft and up to the stop. Use the assembly sleeve from 7. to do this.
9. Push the spacing ring 0504.09 onto the shaft 0211.00.	10. Pull the assembly sleeve off the shaft 0211.00.

- a. OPTIMOL paste TA, assembly tool kit auxiliary material 6
 b. Assembly tool kit tool 3B - for Ø 30
 c. Assembly tool kit tool 3a - for Ø 40
 d. Assembly tool kit tool 12b - for Ø 30
 e. Assembly tool kit tool 12a - for Ø 40

For assembling the impeller and volute casing read on at section 6.5.11, page 45.

6.5.8 Assembly of single mechanical seal (C)

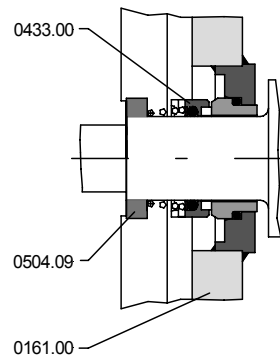

K.0173V1

Fig. 17 Single mechanical seal (C)

Features of the mechanical seal

- Single mechanical seal
- Seat in solid backplate 0161.00

Assemble the mechanical seal in this way:

Please note

The part numbers given in the following instructions may be found in tab. 14.

The assembly aids listed here may be found on page 49.

1. Grease the centring between the backplate 0161.00 and the lantern 0340.00 ^a . Use Klüberpaste UH1 84-201 from HILGE Assembly Tool Kit to do this (Pos. 6, fig. 35).	2. Assemble the backplate 0161.00 on the lantern 0340.00. See fig. 13, page 36.
3. Push assembly sleeve ^{bc} from HILGE assembly tool kit (pos. 12, fig. 35) onto the shaft 0211.00 up to the stop.	4. Spray the assembly sleeve and shaft 0211.00 with clean water. Use spray bottle from HILGE assembly tool kit (pos. 2, fig. 35).
5. Push the fixed part of the mechanical seal 0433.00 over the assembly sleeve into the seat. Use the installation sleeve from HILGE assembly tool kit (pos. 12, fig. 35) to do this. ^{de}	6. Push the rotating ring of the mechanical seal 0433.00 onto the shaft 0211.00 and up to the stop. Use the assembly sleeve from HILGE assembly tool kit (pos. 1, fig. 35) to do this.
7. Push the spacing ring 0504.09 onto the shaft.	8. Pull the assembly sleeve off the shaft 021.00.

- a. OPTIMOL paste TA, assembly tool kit auxiliary material 6
- b. Assembly tool kit tool 3B - for Ø 30
- c. Assembly tool kit tool 3a - for Ø 40
- d. Assembly tool kit tool 12b - for Ø 30
- e. Assembly tool kit tool 12a - for Ø 40

For assembling the impeller and volute casing read on at section 6.5.11, page 45.

6.5.9 Assembly of single mechanical seal (D)

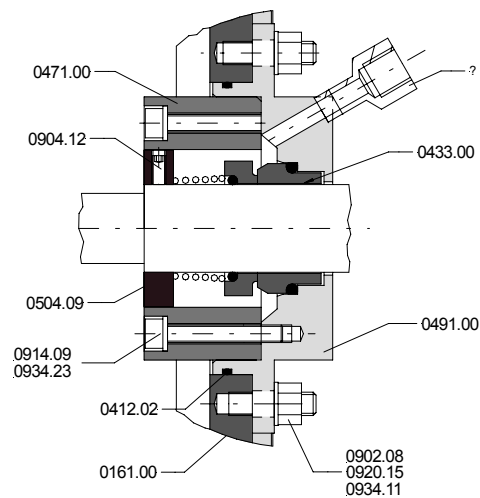

K.0174V1

Fig. 18 Single mechanical seal (D)

Features of the mechanical seal

- Single mechanical seal
- Seat in seal cartridge 0491.00
- Mechanical seal flushed (lost flush)

Assemble the mechanical seal in this way:

Please note

The part numbers given in the following instructions may be found in tab. 14.

The assembly aids listed here may be found on page 49.

1. Insert the O-ring 0412.02 into groove of the seal cartridge 0491.00.	2. Push mechanical seal cartridge 0491.00 into the backplate 0161.00.
3. Fasten seal cartridge 0491.00 on the backplate 0161.00. Use spring washers 0934.11 and hexagon nuts 0920.15 to do this.	4. Grease the centring between the backplate 0161.00 and the lantern 0340.00 ^a . Use Klüberpaste UH1 84-201 from HILGE Assembly Tool Kit to do this (Pos. 6, fig. 35).
5. Mount backplate 0161.00 with seal cartridge 0491.00 installed on the lantern 0340.00. See fig. 13, page 36.	6. Push assembly sleeve ^{bc} onto the shaft 0211.00 up to the stop.
7. Spray the assembly sleeve and shaft 0211.00 with clean water Use spray bottle from HILGE assembly tool kit (pos. 2, fig. 35).	8. Push the fixed part of the mechanical seal 0433.00 over the assembly sleeve into the seat. Use the assembly sleeve to do this ^d .
9. Push the rotating part of the mechanical seal 0433.00 onto the shaft and up to the stop 0211.00. Use the assembly sleeve from step 8. to do this.	10. Push the spacing ring 0504.09 onto the shaft 0211.00.
11. Fasten the spacing ring 0504.09 onto the shaft 0211.00. Tighten grub screw 0904.12 to do this.	12. Fasten seal cover 0471.00 onto seal cartridge 0491.00. Use the spring washers 0943.23 and socket head cap screws 0914.09 to do this. Torque M6: 8 Nm.
13. Pull the assembly sleeve off the shaft 0211.00.	

- a. OPTIMOL paste TA, assembly tool kit auxiliary material 6
- b. Assembly tool kit tool 3B - for Ø 30
- c. Assembly tool kit tool 3a - for Ø 40
- d. Assembly tool kit tool 12b - for Ø 30

For assembling the impeller and volute casing read on at section 6.5.11, page 45 .

6.5.10 Assembly of double mechanical seal (E)

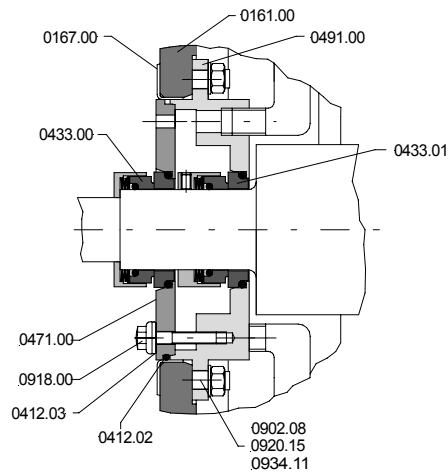

Fig. 19 Double mechanical seal (E)

Features of the mechanical seal

- Double mechanical seal, tandem - arrangement
- Seat in seal cartridge 0491.00
- Mechanical seals, flushed

Assemble the double mechanical seal in this way:

Please note

The part numbers given in the following instructions may be found in tab. 14.

The assembly aids listed here may be found on page 49.

1. Insert the casing backplate liner 0167.00 into backplate 0161.00.	2. Insert the O-ring 0412.02 into the groove of the seal cartridge 0491.00. Push mechanical seal cartridge 0491.00 into backplate 0161.00.
3. Fasten seal cartridge 0491.00 on the backplate 0161.00. Use spring washers 0934.11 and hexagon head screws 0920.15 to do this.	4. Grease the centring between the backplate 0161.00 and the lantern 0340.00 ^a .
5. Fasten backplate 0161.00 with seal cartridge 0491.00 installed on the lantern 0340.00. As you do so, watch carefully the position of the rinsing connections at 12:00 and 6:00.	6. Push assembly sleeve ^{bc} onto the shaft up to the stop.
7. Spray the assembly sleeve and shaft 0211.00 with clean water. Use spray bottle from HILGE assembly tool kit (pos. 2, fig. 35).	8. Push the fixed part of the mechanical seal 0433.01 over the assembly sleeve into the seat. Use the assembly sleeve to do this ^d .
9. Push the rotating part of the mechanical seal 0433.01 onto the shaft. Use the assembly sleeve from 8. to do this.	10. Adjust the mechanical seal 0433.01 to the correct installation dimension. (Spring travel approx. 1.5 mm).
11. Lock the mechanical seal in place on the shaft 0211.00. Tighten the grub screw in the mechanical seal to do this.	12. Insert the O-ring 0412.02 onto the seal cover 0471.00.
13. Fasten seal cover 0471.00 onto seal cartridge 0491.00. Use O-rings 0412.03 and sterile screws 0918.00 for this purpose. Torque M6: 8 Nm.	14. Push the fixed part of the mechanical seal 0433.00 over the assembly sleeve into the seat in the mechanical seal 0471.00. Use the assembly sleeve from step 8. to do this.

15. Push the rotating part of the mechanical seal 0433.00 onto the shaft.
Use the assembly sleeve from step 8. to do this.

16. Pull the assembly sleeve off the shaft 0211.00.

- a. OPTIMOL paste TA, assembly tool kit auxiliary material 6
- b. Assembly tool kit tool 3B - for Ø 30
- c. Assembly tool kit tool 3a - for Ø 40
- d. Assembly tool kit tool 12b - for Ø 30

For assembling the impeller and volute casing read on at section 6.5.11, page 45.

6.5.11 Assembly of the impeller and volute casing

Assemble the impeller and volute casing in this way:

Please note

The part numbers given in the following instructions may be found in tab. 14.

1. Insert key 0940.00.



Fig. 20 Key

2. Grease the impeller seat and the pump shaft 0211.00.

Use Klüberpaste UH1 96-402 from HILGE assembly tool kit for this (pos. 6, fig. 35).



Fig. 21 Pump shaft

3. Fit the impeller 0230.00.



Fig. 22 Impeller

4. Grease the Nord-Lock washers 0930.00 by using Klüberpaste UH1 96-402 from the HILGE assembly tool kit (pos. 6, fig. 35).

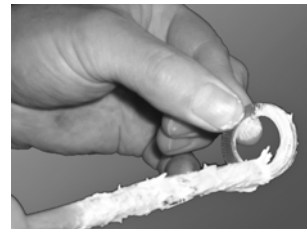

Fig. 23 Nord-lock washers

5. Grease Nord-Lock washers as shown.

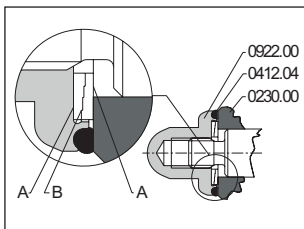

Fig. 24 Schema of Nord-Lock washers greasing

6. Insert the Nord-Lock washers 0930.00 into the impeller nut 0922.00.



Fig. 25 Nord-Lock washers in impeller nut

- 0230.00 impeller
- 0412.04 O-ring
- 0922.00 impeller nut
- A - fine tothing - greased
- B - thick tothing against each other - greased

7. Tighten the impeller nut 0922.00 by hand. Let about 5 mm space for the O-ring 0412.04.^A



Fig. 26 Impeller nut

8. Wet O-ring 0412.04 with clean water and slide it over the impeller nut 0922.00 into the gap between impeller nut 0922.00 and impeller 0230.00.^A



Fig. 27 O-ring

^A) Applies to EPDM and Viton O-ring.
In case of other O-ring materials insert O-ring into impeller nut 0922.00 before the nut will be screwed on.

9. Tighten the impeller nut 0922.00 by using the following torques:
- M20 - 100-120 Nm
 - M24 - 180-230 Nm
 - M30 - 210-250 Nm



Fig. 28 Impeller nut

10. Release the spring of the rotating ring of the mechanical seal against the impeller 0230.00.

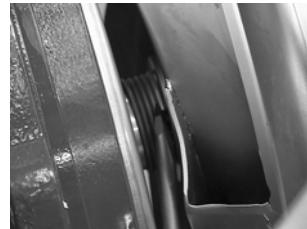

Fig. 29 Spring of mechanical seal

11. Insert the O-ring 0412.00 into the casing backplate liner 0167.00.



Fig. 30 O-ring in casing backplate liner

12. Join the volute casing 0102.00 and the lantern 0340.00.
Pay attention to the right direction of the volute casing 0102.00.



Fig. 31 Volute casing and bearing housing

13. Grease the studs 0902.02 of the volute casing 0102.00.
Use Klüberpaste UH1 96-402 from Hilge assembly tool kit (pos 6., fig. 35).



Fig. 32 Studs of volute casing

14. Assemble the volute casing 0102.00 and the lantern 0340.00 by using the spring washers 0934.00 und the hexagon nuts 0920.04.

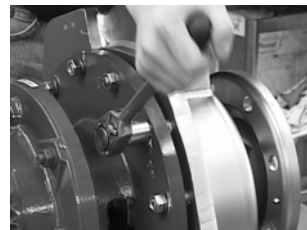

Fig. 33 Volute casing and bearing housing

Maintenance / servicing

15. Tighten the hexagon nuts 0920.04 in the order shown below.

Torque: M10 - 37, M12 - 65 Nm.

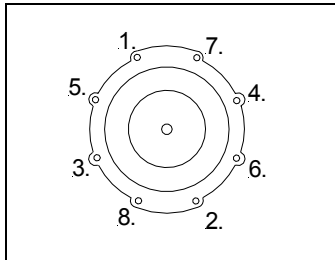

Fig. 34 Tightening order

6.6 Troubleshooting

Problem	Cause	Remedy
Pump does not deliver or delivers at a reduced rate.	<ol style="list-style-type: none"> 1. Incorrect electrical hook-up (2 phases). 2. Wrong rotational direction. 3. Air in the suction line or in the pump.^a 4. Back pressure too high. 5. Suction head too high, NPSH feed too low. 6. Lines clogged or foreign material in the impeller. 7. Air inclusions as a result of a defective seal. 	<ol style="list-style-type: none"> 1. Check the electrical connections and correct them if necessary. 2. Reverse the phases of the power supply (reverse the polarity). 3. Vent the suction line or the pump and refill. 4. Reset the operating point according to the data sheet. Check system for contamination. 5. Raise the liquid level on the suction side. Open the shut-off valve in the suction line all the way. Produce the conditions described in section 3.3. Consult manufacturer. 6. Open the pump and fix the problem. 7. Check the pipeline seals, the pump housing seals, and the shaft seals. Replace if necessary.
Motor safety switch turns motor off. Motor is overloaded.	<ol style="list-style-type: none"> 1. Pump jammed because of clogging. 2. Pump jammed by contact because pump body was twisted by the pipelines. (Check for damage). 3. Pump continues to run beyond the rated operating point. 4. The density or viscosity of the pumping medium is higher than the value stated in the order. 5. Motor safety switch not properly adjusted. 6. Motor running on 2 phases. 	<ol style="list-style-type: none"> 1. Open the pump and fix the problem. 2. Install the pump so that there is no stress on it. Support the pipelines at fixed points. 3. Set the operating point according to the data sheet. 4. If it is acceptable for the performance to be lower than that stated, decrease the delivery rate on the pressure side. Otherwise, use a more powerful motor. Consult manufacturer. 5. Check the setting. Replace the safety switch if necessary. 6. Check the electrical connections. Replace defective fuses.

Tab. 16 Troubleshooting

Problem	Cause	Remedy
Pump produces too much noise. Pump runs roughly and vibrates.	<ol style="list-style-type: none"> 1. Suction head too high, NPSH feed too low. 2. Air in the suction line or in the pump.^a 3. Back pressure lower than stated. 4. Impeller out of balance. 5. Internal parts worn. 6. Pump is twisted (causing contact noises). Check for damage. 7. Bearings are defective. 8. Bearings have too little, too much, or the wrong kind of lubricant. 9. Motor cooling fan defective. 10. Gear ring of the coupling (power transmission) defective.^b 11. Foreign material in the pump. 	<ol style="list-style-type: none"> 1. Raise the liquid level on the suction side. Open the shut-off valve in the suction line all the way. Produce the conditions described in section 3.3. Consult manufacturer. 2. Vent the suction line or the pump and refill. 3. Set the operating point according to the data sheet. 4. Clean, inspect, and rebalance the impeller. 5. Replace parts. 6. Install the pump so that there is no stress on it. Support the pipelines at fixed points. 7. Replace the bearings. 8. Add more lubricant, decrease the amount, or replace the lubricant. 9. Replace the motor cooling fan. 10. Replace the gear ring of the coupling. Realign the coupling. 11. Open the pump and clean it (install a screen in front of self-priming pumps, if necessary).
Leakage at the pump body, at the connections, at the mechanical seal and at the stuffing box or gland seal.	<ol style="list-style-type: none"> 1. Pump is twisted (causing leaks at the pump body or at the connections). 2. Housing seals and seals at the connections are defective. 3. Rotating mechanical seal dirty or stuck. 4. Rotating mechanical seal worn. 5. Stuffing box packing worn out. 6. Surface of shaft or shaft safety sleeve worn down. 7. Elastomer unsuitable for the pumping medium. 	<ol style="list-style-type: none"> 1. Install the pump so that there is no stress on it. Support the pipelines at fixed points. 2. Replace the housing seals or the seals of the connections. 3. Inspect and clean the rotating mechanical seal. 4. Replace mechanical seal. 5. Tighten the stuffing box packing, add more packing, or replace the packing. 6. Replace the shaft or the shaft safety sleeve. Repack the stuffing box. 7. Use an elastomer suitable for the pumping medium and the temperature.
Unallowable temperature increase at the pump, bearing housing, or motor.	<ol style="list-style-type: none"> 1. Air in the suction line or in the pump.^a 2. Bearings have too little, too much, or the wrong kind of lubricant. 3. Pump and bearing housing are twisted. 4. Axial thrust too high.^a 5. Motor safety switch is defective or not properly adjusted. 6. Pressure valve closed. 	<ol style="list-style-type: none"> 1. Vent the suction line or the pump and refill. 2. Add more lubricant, decrease the amount, or replace it. 3. Install the pump so that there is no stress on it. Support the pipelines at fixed points. Check the alignment of the coupling. 4. Inspect the relief holes in the impeller and the split rings at the inlet. 5. Check the adjustment. Replace the motor safety switch if necessary. 6. Open the pressure valve.

Tab. 16 Troubleshooting

- a. Applies not to self priming pumps.
b. Applies to CN baseplate design.

6.7 Disposal

This product or parts of it must be disposed of in an environmentally sound way:

1. Use the public or private waste collection service.
2. If this is not possible, contact the nearest GEA Hilge company or service workshop.

Maintenance / servicing

6.8 HILGE assembly tool kit

Remove and install the mechanical seals safely and reliably by using tools of the HILGE assembly tool kit.

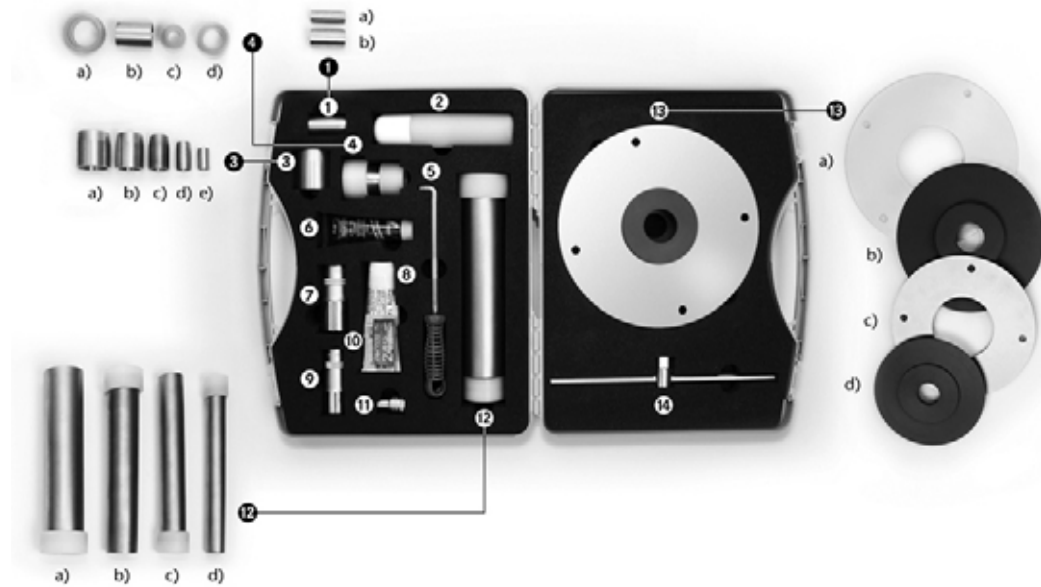

K.0266V1

Fig. 35 HILGE assembly tool kit

6.8.1 Content and use

Item (fig.)	Description - shaft diameter	80-160	100-200 / 100-250 100-315 / 125-250 80-200 / 80-250 / 80-315	125-315 / 150-250 / 150-315 / 150-400 / 200-400
2	spray bottle	•	•	•
3a	assembly sleeve Ø 50			•
3b	assembly sleeve Ø 40		•	
3c	assembly sleeve Ø 30	•		
4a	plastic adapter Ø 40		•	
4d	plastic adapter Ø 30	•		
5	ejector for mechanical seal - stationary ring	•	•	•
6	Klüberpaste UH1 96-402	•	•	•
7	socket wrench SW 27	•		
7	socket wrench SW 32		•	
7	socket wrench SW 50			•
7	plastic socket spanner insert SW 27	•		
8	Optinol Paste TA	•	•	•
10	screw locking Loctite Typ 243	•	•	•
12a	mechanical seal installation sleeve with plastic adapter Ø 50			•
12b	mechanical seal installation sleeve with plastic adapter Ø 38 und Ø 40		•	
12c	mechanical seal installation sleeve with plastic adapter Ø 28 und Ø 30	•		

Tab. 17 HILGE-assembly tool kit

7. Certificate of non-objection

Overview

This section contains a certificate of non-objection. In case of inspection or repairing send the pump including these certificate to HILGE.

7.1 Certificate of non-objection

The following pump and its accessories, together with this certificate of non-objection, are herewith contracted out by the undersigned for inspection/repair:

- Pump data
- Model:
 - No.:
 - Delivery Date:

Reason for inspection / repair contract:

The pump (please mark with a cross)

___ was not used in media hazardous to health

___ was used for the following: _____

Please state the last medium to be pumped, if known:

The pump was carefully drained and also cleaned inside and out before it was shipped/made available. (please mark with a cross)

___ No special safety measures are required in the course of further handling.

___ The following safety measures pertaining to flushing media, residual liquids, and disposal are required:

We confirm that the information given above is correct and complete and that shipment is in compliance with legal regulations.

Company (address):

Telephone, fax, email

Name (please print), title

Date

Company stamp / signature

GEA Hilge
Niederlassung der GEA Tuchenhagen GmbH
Hilgestraße 37 – 47
55294 Bodenheim, Germany

Tel +49 6135 7016-0

© GEA Hilge. All rights reserved. Subject to modifications. Printed in Germany.