

Operating Instructions

VARIVENT[®] **Vacuum Valve V - Version EX**

Edition 2015-12-09
English

Product Vacuum Valve V - Version EX

Document Operating Instructions
Edition 2015-12-09
English

Manufacturer GEA Tuchenhagen GmbH
Am Industriepark 2-10
D-21514 Büchen
Phone: +49 4155 49-0
Fax: +49 4155 49-2423
Mail: sales.geatuchenhagen@gea.com
Web: <http://www.tuchenhagen.com>

This document is protected by copyright. All rights reserved. The document may not, in whole or in part, be copied, reproduced, translated or reduced to an electronic medium of machine-readable form without the express permission of GEA Tuchenhagen GmbH.

Wordmarks The designation VARIVENT® is a protected trademark of GEA Tuchenhagen GmbH.

Table of Contents

Notes for the Reader	5
Binding Character of These Operating Instructions	5
Notes on the Illustrations	5
Symbols and Highlighting	6
Abbreviations and Terms	7
Safety	9
Safety Note	9
Operator's Duties	9
Qualification of Staff	10
Supplementary Regulations	11
Instructions for the Safe Operation	12
• General Principles	12
• Installation	12
• Commissioning/Setup Mode	13
• Setting into Operation	13
• Operation	13
• Shutting Down	14
• Maintenance and Repair	14
• Disassembly	15
• Environmental Protection	15
• Electrical Equipment	15
Signage	16
Residual Risk	16
• Hazard Areas	16
• Residual Dangers	17
• Declaration of Incorporation	18
Transport and Storage	19
Scope of Supply	19
Transport	19
Storage	19
Intended Purpose	20
Designated Use	20
Requirements for the Operation	20
Improper Operating Conditions	20
Conversion Work	21
Design	22
Installation and Commissioning	23
Notes on Installation	23
Valve with Detachable Pipe Connection Elements	23
Valve with Welding Ends	24
Pneumatic Connections	24
Electrical Connections	25
Commissioning	26

Malfunctions	27
Maintenance	28
Inspections	28
• Product Contact Seals	28
• Pneumatic Connections	28
• Electrical Connections	29
Maintenance Intervals	29
Removing the Valve	30
Disassembling the Valve	31
• Type V... Without Feedback	31
• Type V...E With Feedback	32
• Type V...A With Lifting Actuator	32
• Type V...R With Lifting Actuator and Feedback	33
Maintenance	34
• Cleaning the Valve	34
• Replacing Wearing Parts	35
• Lubricating Seals and Threads	36
Assembling the Valve	37
Torques for the Cast Clamps and Clamp joints	39
Setting the Proximity Switches	40
• Vacuum Valve with Lifting Actuator Type V...R	40
• Vacuum Valve with Lifting Actuator Type V...E	41
Disposal	42
Technical Data	43
Type Plate	43
Technical Data	43
Resistance of Sealing Materials	45
Pipe Ends	46
Tools	46
Lubricants	46
Weights	46
Spare Parts Lists	47
Dimension Sheet	50

Notes for the Reader

The present Operating Instructions are part of the user information for the valve. The Operating Instructions contain all the information you need to transport, install, commission, operate and carry out maintenance for the valve.

Binding Character of These Operating Instructions

These Operating Instructions contain the manufacturer's instructions to the owner of the valve and to all persons who work on or use the valve regarding the procedures to follow.

Carefully read these Operating Instructions before starting any work on or using the valve. Your personal safety and the safety of the valve can only be ensured if you act as described in the Operating Instructions.

Store the Operating Instructions in such a way that they are accessible to the owner and the operating staff during the entire life cycle of the valve. When the location is changed or the valve is sold make sure you also provide the Operating Instructions.

Notes on the Illustrations

The illustrations in these Operating Instructions show the valve in a simplified form. The actual design of the valve can differ from the illustration. For detailed views and dimensions of the valve please refer to the design documents.

Symbols and Highlighting

In these Operating Instructions, important information is highlighted by symbols or special formatting. The following examples illustrate the most important types of highlighting.



DANGER

Warning: Fatal injuries.

Failure to observe the warning can cause serious damage to health, or even death.

→ The arrow identifies a precautionary measure you have to take to avoid the hazard.



EXPLOSION HAZARD

Warning: Explosions.

Failure to observe the warning may result in a severe explosion.

→ The arrow identifies a precautionary measure you have to take to avoid the hazard.



WARNING

Warning: Serious Injuries.

Failure to observe the warning note can result in serious damage to health.

→ The arrow identifies a precautionary measure you have to take to avoid the hazard.



CAUTION

Warning: Injuries.

Failure to observe the warning note can result in minor or moderate damage to health.

→ The arrow identifies a precautionary measure you have to take to avoid the hazard.

IMPORTANT NOTE

Warning: Damage to Property.

Non-observance of the warning note can cause serious damage to the valve or the vicinity of the valve.

→ The arrow identifies a precautionary measure you have to take to avoid the hazard.

Carry out the following steps: = Start of a set of instructions.

1. First step in a sequence of operations.
 2. Second step in a sequence of operations.
 - ↳ Result of the previous operation.
- ✓ The operation is complete, the goal has been achieved.

NOTE

Further useful information.

Abbreviations and Terms

Abbreviation	Explanation
BS	British Standard
bar	Unit of measurement of pressure [bar] All pressure ratings [bar/psi] stand for over pressure [bar _g /psi _g] if this is not explicitly described differently.
approx.	approximately
°C	Unit of measurement of temperature [degree Celsius]
dm ³ _n	Unit of measurement of volume [cubic decimetre] Volume (litre) at standard temperature and pressure
DN	DIN nominal width
DIN	German standard issued by DIN (Deutsches Institut für Normung e.V, German Institute for Standardization)
EN	European Standard
EPDM	Material designation Short designation according to DIN/ISO 1629: Ethylene Propylene Diene Rubber
°F	Unit of measurement of temperature [degree Fahrenheit]
FKM	Material designation, short designation according to DIN/ISO 1629: Fluorine rubber
h	Unit of measurement of time [hour]

Abbreviation	Explanation
HNBR	Material designation Short designation according to DIN/ISO 1629: Hydrogenated Acrylonitrile Butadiene Rubber
IP	Protection class
ISO	International standard issued by the International Organization for Standardization
kg	Unit of measurement of weight [kilogram]
kN	Unit of measurement of force [kilonewton]
L	Unit of measurement of volume [litre]
max.	maximum
mm	Unit of measurement of length [millimetre]
µm	Unit of measurement of length [micrometre]
M	metric
Nm	Unit of measurement of work [newton metre] UNIT OF TORQUE 1 Nm = 0.737 lbft Pound-Force (lb) + Feet (ft)
PA	Polyamide
PE-LD	Low-density polyethylene
SET-UP	Self-learning installation During commissioning and maintenance, the SET-UP procedure carries out all the necessary settings for the generation of messages.
a/f	Indicates the size of spanners width across flats
T.VIS	Tuchenhagen Valve Information System
V AC	Volt alternating current
V DC	Volt direct current
W	Unit of measurement of power [Watt]
TIG	Welding method Tungsten inert gas welding
Inch OD	Pipe dimension acc. to British standard (BS), Outside Diameter
Inch IPS	US pipe dimension Iron Pipe Size

Safety

Safety Note

The valve is operationally reliable. It was built according to state-of-the art standards.

Nevertheless, the valve can pose dangers, especially if

- the valve is not used in accordance with its intended use,
- the valve is not used correctly,
- the valve is operated under impermissible operating conditions.

Operator's Duties

In your capacity as operator of the facility you bear a particular responsibility for the proper and safe handling of the valve in your facility. Only use the valve when it is in perfect condition to prevent danger to persons and property.

These Operating Instructions contain the information you and your staff need for the safe and reliable operation during the entire service life of the valve. Be sure to read these Operating Instructions carefully and ensure that the measures described here are observed.

The operator's duty of care includes planning the necessary safety measures and monitoring that these measures are observed. The following principles apply:

- Only allow qualified staff to work on the valve.
- The operator must authorize the staff to carry out the relevant tasks.
- Working areas and the entire environment of the valve must be neat and clean.
- The staff must wear suitable work clothing and personal protective equipment. As the operator of the facility make sure that work clothing and personal protective equipment are used.
- Instruct the staff with regard to any properties of the product which might pose a health risk and the preventative measures to be taken.
- Have a qualified first-aider on call during the operation, who can initiate the necessary first-aid measures in case of an emergency.
- Clearly define processes, lines of authority and responsibilities associated with the valve. Everybody must know what to do in case of an emergency. Instruct the staff in this respect at regular intervals.
- The signs relating to the valve must always be complete and legible. Check, clean and replace the signs as necessary at regular intervals.

NOTE

Carry out regular checks. This way you can ensure that these measures are actually observed.

Qualification of Staff

This section contains information about the qualifications that staff working on the valve must have.

Operating and maintenance staff must

- have the necessary qualification to carry out their tasks,
- be instructed with regard to possible dangers,
- know and observe the safety instructions given in the documentation.

Only allow qualified electricians to carry out work on the electrical equipment or have a qualified electrician supervise the work.

Only allow specially trained staff to carry out any work on explosion-protected equipment. When working on explosion-protected equipment observe the standards DIN EN 60079-14 for gases and DIN EN 50281-1-2 for dusts.

The following minimum qualifications are required:

- Vocational training as a specialist who can work on the valve independently.
- Sufficient instruction to work on the valve under the supervision and direction of a qualified specialist.

Each member of staff must meet the following requirements to be allowed to work on the valve:

- Personal qualification for the relevant task.
- Sufficient professional qualification for the relevant task.
- Instructed with regard to the function of the valve.
- Instructed with regard to the operating sequences of the valve.
- Familiar with the safety devices and their function.
- Familiar with these Operating Instructions, especially with the safety instructions and the information which is relevant for the task on hand.
- Familiar with the basic regulations with regard to occupational health and safety and accident prevention.

For work to be carried out on the valve the following user groups are distinguished:

User groups

Staff	Qualifications
Operating staff	<p>Adequate instruction and sound knowledge in the following areas:</p> <ul style="list-style-type: none"> • Function of the valve • Valve operating sequences • What to do in case of an emergency • Lines of authority and responsibilities with respect to the task.

User groups (Cont.)

Staff	Qualifications
Maintenance staff	<p>Adequate instruction as well as sound knowledge of the design and function of the valve.</p> <p>Sound knowledge in the following areas:</p> <ul style="list-style-type: none"> • Mechanical equipment • Electrical equipment • Pneumatic system <p>Authorization with regard to safety engineering standards to carry out the following tasks:</p> <ul style="list-style-type: none"> • Setting devices into operation • Earthing of devices • Marking of devices <p>The relevant certificates of qualification must be submitted before work can be carried out on ATEX certified machines.</p>

Supplementary Regulations

In addition to the instructions in this documentation the following also has to be observed:

- pertinent accident prevention regulations,
- generally accepted safety rules,
- national regulations applicable in the country of use,
- work and safety instructions applicable in the facility,
- installation and operating regulations for use in potentially explosive areas.

Instructions for the Safe Operation

Dangerous situations during the operation can be avoided by safety-conscious and proactive behaviour of the staff.

General Principles

To ensure the safe operation of the valve the following principles apply:

- The Operating Instructions must be kept ready to hand at the valve's place of use. They must be complete and in clearly legible form.
- Only use the valve for its intended use.
- The valve must be functional and in good working order. Check the condition of the valve before starting work and at regular intervals.
- Wear tight-fitting work clothing for all work on the valve.
- Ensure that nobody can get hurt on the parts of the valve.
- Immediately report any faults or noticeable changes on the valve to the person responsible.
- Observe the accident prevention regulations and all local regulations.

Installation

For installation, the following principles apply:

- Only properly qualified staff is allowed to install, assemble and set the valve into operation.
- Ensure that adequate working and traffic areas are available at the place of installation.
- Observe the maximum load-bearing capacity of the installation surface.
- Observe the transport instructions and markings on the part(s) to be transported.
- Remove any nails protruding from transport crates immediately after opening the crate.
- Under no circumstances should anyone stand under a suspended load.
- During assembly, the valve safety devices might not be working effectively.
- Reliably secure machine parts which have already been connected against inadvertently being switched on.

Commissioning/Setup Mode

For commissioning, the following principles apply:

- Take protective measures against dangerous contact voltages in accordance with pertinent regulations.
- The valve must be completely assembled and correctly adjusted. All screw connections must be securely tightened. All electrical cables must be installed correctly.
- Reliably secure machine parts which have already been connected against inadvertently being switched on.
- Relubricate all lubricating points.
- Make sure lubricants are used properly.
- After conversion of the valve, residual risks must be reassessed.

Setting into Operation

For setting into operation, the following principles apply:

- Only allow properly qualified staff to set the valve into operation.
- Establish all connections correctly.
- The safety devices for the valve must be complete, fully functional and in perfect condition. Check the function before starting any work.
- When the valve is switched on, the danger zones must be free.
- Remove any liquids that have escaped without leaving residues.

Operation

For operation, the following principles apply.

- Monitor the valve during the operation.
- Safety devices must not be changed, removed or taken out of service. Check all safety devices at regular intervals.
- All guards and hoods must be fitted as intended.
- The place of installation of the valve must be adequately ventilated at all times.
- Structural alterations of the valve are not permitted. Immediately report any changes on the valve to the person responsible.
- Always keep danger zones clear. Do not leave any objects in the danger zone. Only allow persons to enter the danger zone when the machine is de-energized.
- Regularly check that all emergency stop devices are working correctly.

Shutting Down

For shutting down, the following principles apply:

- Switch off the compressed air.
- Switch off the valve via the main switch.
- Padlock the main switch (if fitted) in the off position to prevent it from being switched back on. The key to the padlock must be deposited with the person responsible until the machine is restarted.
- For longer periods of standstill, observe the storage conditions, see Storage (Page 19).

Maintenance and Repair

Before starting any maintenance and repair work on the electrical devices of the valve, carry out the following steps in accordance with the "5 safety rules":

- Isolate from the power supply
- Take appropriate measures to prevent switch on
- Test absence of voltage
- Earthing and short-circuiting
- Cover or safeguard any adjacent live parts.

For maintenance and repair, the following principles apply:

- Observe the intervals specified in the maintenance schedule.
- Only allow qualified staff to carry out maintenance or repair work on the valve.
- Before starting any maintenance or repair work, the valve must be switched off and secured against being switched back on. Work may only be started once any residual energy has been discharged.
- Block access for unauthorized persons. Put up notice signs which draw attention to the maintenance or repair work going on.
- Do not climb on the valve. Use suitable access aids and working platforms.
- Wear suitable protective clothing.
- Only use suitable and undamaged tools to carry out maintenance work.
- When replacing parts only use approved, fully functional load lifting devices and lifting accessories which are suitable for the intended purpose.
- Before setting the valve back into operation refit all safety devices as originally provided in the factory. Then check that all safety devices are working correctly.
- Make sure lubricants are used properly.
- Check pipes are firmly secured, also check for leaks and damage.
- Check that all emergency stop devices are working correctly.

Disassembly

For disassembly, the following principles apply:

- Only allow qualified staff to disassemble the valve.
- Before starting disassembly, the valve must be switched off and secured against being switched back on. Work may only be started once any residual energy has been discharged.
- Disconnect all power and utility lines.
- Markings, e.g. on lines, must not be removed.
- Do not climb on the valve. Use suitable access aids and working platforms.
- Mark the lines (if unmarked) prior to disassembly to ensure they are not confused when re-assembling.
- Protect open line ends with blind plugs against ingress of dirt.
- Pack sensitive parts separately.
- For longer periods of standstill, observe the storage conditions, see Storage (Page 19).

Environmental Protection

Harm to the environment can be avoided by safety-conscious and proactive behaviour of the staff.

For environmental protection the following principles apply:

- Substances harmful to the environment must not be discharged into the ground or the sewage system.
- Always observe the pertinent regulations relating to waste avoidance, disposal and utilization.
- Substances harmful to the environment must be collected and stored in suitable containers. Clearly mark the containers.
- Dispose of lubricants as hazardous waste.

Electrical Equipment

For all work on electrical equipment, the following principles apply:



- Access to electrical equipment should only be allowed to qualified electricians. Always keep unattended switch cabinets locked.
- Modifications of the control system can affect the safe and reliable operation. Modifications are only permitted with the express permission of the manufacturer.
- After completion of all work, check that the protective devices are fully functional.

Signage

Dangerous points on the valve are indicated by warning signs, prohibition signs and mandatory signs.

The signs and notes on the valve must always be legible. Any illegible signs must be replaced immediately.

Signs on the valve

Sign	Meaning
	General hazard warning
	Warning Crushing
	Explosive atmosphere hazard warning

Residual Risk

Hazard Areas

Please observe the following notes:

- In the event of malfunctions, shut down the valve (disconnect from the power and air supply) and secure it against being used.
- Before starting any service, maintenance or repair work, disconnect the valve from the power supply and secure it against inadvertently being switched back on again.
- Only allow a qualified electrician to carry out any work on the electrical power supply.
- Check the electrical equipment of the valve at regular intervals. Immediately remedy loose connections and molten cables.
- If work on live parts cannot be avoided, call in a second person, who can operate the main switch in case of an emergency.
- The housing sockets have very sharp edges. When transporting and assembling the valve be sure to wear suitable protective gloves.
- During cleaning via lifting function, cleaning agents can spray out of the collecting pan for the vacuum valve as a result of excess pressure in the container to be cleaned, sometimes in considerable quantities. Only use the lifting function when the container is unpressurized and the collecting pan for the vacuum valve is empty.

Residual Dangers

Dangerous situations can be avoided by safety-conscious and proactive behaviour of the staff and by wearing personal protective equipment.

Residual dangers on the valve and measures

Danger	Cause	Measure
Danger to life	Inadvertent switch-on of the valve	Effectively disconnect all components, effectively prevent switch-on.
	Electric power	Observe the following safety rules: 1 Isolate from the power supply. 2 Take appropriate measures to prevent switch on. 3 Test absence of voltage. 4 Earthing and short-circuiting. 5 Cover or safeguard any adjacent live parts.
Danger of injury	Danger presented by moving or sharp-edged parts	The operator must exercise caution and prudence. For all work: <ul style="list-style-type: none"> • Wear suitable work clothing. • Never operate the machine if the cover panels are not correctly fitted. • Never open the cover panels during the operation. • Never reach into openings. As a precautionary measure, wear personal protective equipment in the vicinity of the valve: <ul style="list-style-type: none"> • Protective gloves • Safety shoes
	Cleaning agents can spray out during cleaning by lifting as a result of excess pressure in the container to be cleaned.	If the container to be cleaned is under excess pressure, the pressure is released into the atmosphere during lifting. If this happens during cleaning, when cleaning solution is continuously sprayed into the valve housing, the air flowing out carries the cleaning solution along. This liquid can spray out of the collecting pan for the vacuum pan. Depending on the level of the excess pressure, a considerable amount of cleaning solution can emerge. These effects are physical and cannot be avoided. Observe the following points: <ul style="list-style-type: none"> • Use the lifting function only when the container is not under pressure. • Lift the pressure relief valve disk before lifting the vacuum valve disk, in order to reduce spraying if a residual overpressure exists. • Use the lifting function only when the collecting pan for the vacuum valve is empty. If this is not possible due to process-related reasons, the following step could reduce the amount of cleaning fluid spraying out. Validation must be carried for each individual application to determine whether the remaining amount of cleaning liquid is sufficient to clean the valve seat. <ul style="list-style-type: none"> • Stop the supply pump before lifting the valve disks.
Environmental damage	Operating materials with properties which are harmful to the environment	For all work: <ul style="list-style-type: none"> • Collect lubricants in suitable containers. • Dispose of lubricants in accordance with the pertinent regulations.

Declaration of Incorporation

Declaration of Incorporation

in accordance with the EC Machinery Directive 2006/42/EC

We herewith declare that this consignment contains the subsequently identified – but incomplete – machine and that putting into service is not permitted until it has been established that the machinery into which this machine is to be incorporated is in conformity with the provisions of the EC Machinery Directive.

We declare that the incomplete machine identified here complies with the "Essential Health and Safety Requirements" defined in Annex I, section 1 and section 2.1. The technical documentation is compiled in accordance with Annex VII, part B. In response to a reasoned request the relevant information will be transmitted to the appropriate national authorities.

This declaration will become invalid if any alterations are made to the machine which have not been agreed with us.

Designation of the machine:	Vacuum Valve V
Machine type:	VARIVENT®
Relevant EC directives:	2006/42/EC
Applicable harmonized standards:	DIN EN ISO 12100

Büchen, 06/02/2009

Franz Bürmann
Managing Director

i.V. Peter Fahrenbach
Head of Development and Design

Transport and Storage

Scope of Supply

On receipt of the valve check whether

- the details on the type plate correspond to the data in the order and delivery documents,
- the equipment is complete and all components are in good order.

Transport

For transport, the following principles apply:

- Only use suitable lifting gear and slings for transporting the package units/valves.
- Observe the pictograms on the package.
- Handle valves with care to avoid damaged caused by impact or careless onloading and unloading. The outside synthetic materials are susceptible to breaking.
- The control modules must be protected from animal and vegetable fats.
- Only allow qualified staff to transport the valve.
- Movable parts must be properly secured.
- Only use approved, fully functional load lifting devices and lifting accessories which are suitable for the intended purpose. Observe the maximum load-bearing capacities.
- Secure the valve against slipping. Take the weight of the valve into account and the position of the point of gravity.
- Under no circumstances should anyone stand under a suspended load.
- Take care when transporting the valve. Do not grip sensitive parts of the valve to lift or push the valve or support yourself. Avoid putting the valve down with a jerk.

Storage

Valves, valve inserts or spare parts should be stored in a dry place, free of vibrations and dust. To avoid damage, leave the components in their original packaging if possible.

If, during transport or storage, the valve is going to be exposed to temperatures $\leq 0^{\circ}\text{C}$, it must be dried and suitable measures be taken to protect it from damage.

NOTE

We recommend that the valve should be stored at a temperature of $\geq 5^{\circ}\text{C}$ for a period of 24 hours prior to any handling so that any ice crystals formed by condensation water can melt.

Intended Purpose

Designated Use

The vacuum valve V is used for the automatic compensation of vacuum pressures in tanks or pipes.

Since there is a risk that the valve disk may freeze at temperatures $< 0^{\circ}\text{C}$, it is essential to equip the vacuum valve with a heating device. Otherwise, a reliable function is not ensured.

Tuchenhagen vacuum valves are generally designed for prevention of vacuum caused by free emptying of tanks. Protection against vacuum caused by the hot/cold cleaning of the tank/vessel is not provided.

NOTE

The manufacturer will not accept any liability for damage resulting from any use of the valve which is not in accordance with the designated use of the valve. The risk of such misuse lies entirely with the operator of the facility.

Requirements for the Operation

The prerequisite for the reliable and safe operation of the valve is proper transportation and storage as well as professional installation and assembly. Operating the valve within the limits of its designated use also involves adhering to the operating, inspection and maintenance instructions.

Improper Operating Conditions

The operational reliability of the valve cannot be ensured under improper operating conditions. Therefore avoid improper operating conditions.

Operating the valves is not permitted if

- Persons or objects are in the danger zone.
- Safety devices are not working or were removed.
- Malfunctions have been detected on the valve.
- Damage has been detected on the valve.
- Maintenance intervals have been exceeded.

Conversion Work

You should never make any technical modifications to the valve. Otherwise you will have to undergo a new conformity process in accordance with the EC Machinery Directive on your own.

In general, only original spare parts supplied by GEA Tuchenhausen GmbH should be fitted. This ensures the reliable and economical operation of the valve.

Design

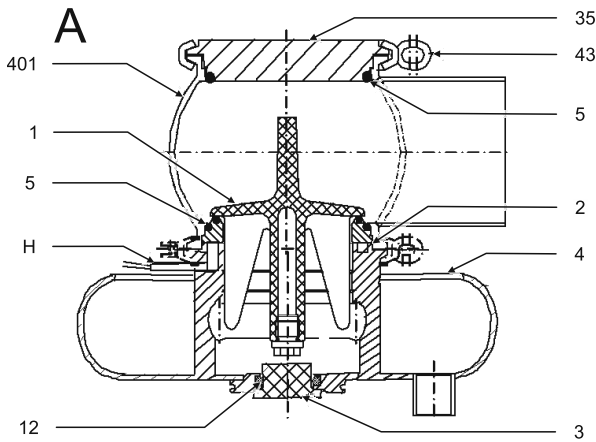

Fig. A: Type V... without feedback
 Fig. B: Type V...R with lifting actuator and feedback

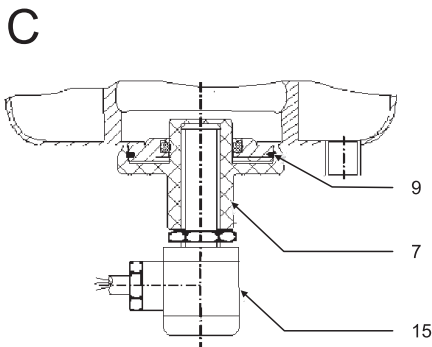
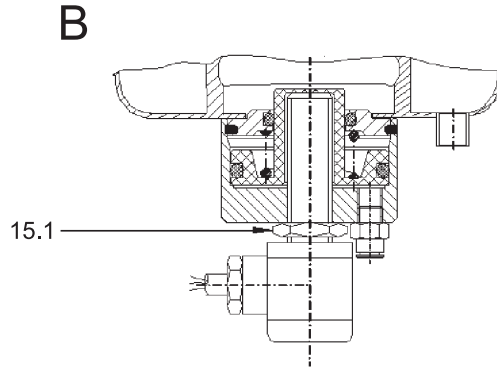
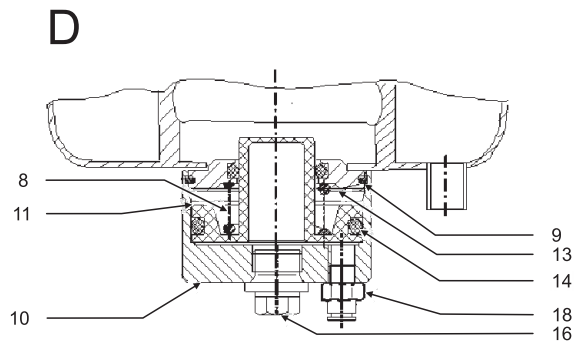

Fig. C: Type V...E without lifting; with feedback
 Fig. D: Type V...A with lifting; without feedback



Item	Designation	Item	Designation
1	Valve disk V	13	Disk
2	Seat	14	Square profile ring
3	Cap V		O-ring
4	Vacuum housing	15	Proximity switch
5	O-ring	15.1	Hex nut
7	Proximity switch mounting	16	Locking screw
8	Pressure spring	18	Screw connection 6 G1/8"
9	Snap ring	35	Cover
10	Cylinder	A	Heater

Installation and Commissioning

Notes on Installation

To prevent damage, make sure that

- the pressure in the tank/pipelines does not exceed 1 bar during valve lifting, as otherwise the piston will be damaged. This refers only to the component "piston". Please observe the safety note and the section on residual dangers, see chapter "Residual Dangers" (Page 17).
- no foreign materials (e.g. tools, bolts, lubricants) are left in the system.

Valve with Detachable Pipe Connection Elements

This section describes the procedure to fit the valve.



CAUTION

Liquids in pipes

Danger of injury due to liquid spraying out

- Therefore, before releasing any pipe connections or clamp joints: drain the pipe and, if necessary, clean or rinse it.
- Separate the pipe section in which the valve is to be fitted from the rest of the piping system to prevent product entering again.

Carry out the following steps:

- Fit valves with detachable pipe connection elements – using suitable connection fittings – directly into the pipe system.
- ✓ Done

Valve with Welding Ends

This section describes the welding procedure for the valve.

IMPORTANT NOTE

Seals are wearing parts

Old seals will cause malfunction of the valve.

→ When fitting the valve be sure to fit new housing O-rings.

Carry out the following steps:

1. Disassemble the valve, see chapter "Disassembling the Valve" (Page 31).
2. Fit the housing without sealing rings.
3. Fit the housing into place and tack it.
4. Always close the housing before welding.
5. Flush the housing with forming gas from the inside to push the oxygen out of the system.
6. Weld the housing into the pipe system; use welding filler if necessary. Use the TIG welding with pulse method.
7. Passivate the seam after welding.
8. Fit the seals.
9. Assemble the valve.

✓ Done

Pneumatic Connections

To ensure reliable operation, the compressed air hoses must be cut exactly square.

Tools required:

- A hose cutter.

Carry out the following steps:

1. Shut off the compressed air supply.
2. Use the hose cutter to cut the pneumatic hoses square.
3. Push the air hose into the screw connection of the lifting actuator.
4. Re-open the compressed air supply.

✓ Done

Electrical Connections



DANGER

Live parts

Electrical shock can result in serious personal injury or death.

- Only allow properly qualified staff to carry out work on the electrical equipment.
- Prior to establishing electrical connections check the maximum permissible operating voltage.



EXPLOSION HAZARD

Explosive gases or dusts

An explosion can result in serious personal injury or death.

- Observe the installation and operating regulations for use in potentially explosive areas.

Carry out the following steps:

- Establish the electrical connections on the valve.

✓ Done

NOTE

The proximity switches are factory set. During transport and installation it can happen that the settings are changed, so that readjustment may be required, see "Setting the Proximity Switches" (Page 40).

Commissioning

During commissioning and in other unpressurized processes in tanks or pipelines the vacuum valve opens if the tank/the pipe are emptied and solely the vacuum valve ensures pressure compensation. This effect can also occur during unpressurized cleaning. Cleaning solution can escape when the valve opens. This behaviour is quite normal and not due to malfunction.

Before starting commissioning observe the following:

- Make sure that there are no foreign materials in the system.
- Actuate the valve once by applying compressed air.
- Clean the pipe system prior to the first product run.
- During commissioning, regularly check all sealing points for leaks. Replace defective seals.

NOTE

When sticky media are used, lift the valve disk during cleaning. This is the only way to prevent parts sticking together so that the valve remains functional.

Malfunctions

In the event of malfunctions immediately deactivate the valve and secure it against inadvertent reactivation. Malfunctions may only be remedied by qualified staff, who must observe the safety instructions.

Malfunction	Cause	Remedy
Valve does not work	Fault in the control system	Check the system configuration
	No compressed air or compressed air too low	Check the compressed air supply Check air hoses for free passage and air tightness
	Fault in the electrical system	Check actuation / external controller and routing of electrical lines
	Ext. solenoid valve defective	Replace the solenoid valve
	Tank pressure too high	Reduce the tank pressure to 1 bar
Valve does not close	Dirt/foreign material between valve seat and valve disk	Clean valve housing and valve seat
	Sealing surfaces damaged	Replace seat and valve disk
	Locking screw in the valve disk not adjusted	Adjust the locking screw
	The proximity switch is set too high on the lifting actuator with feedback version	Set the proximity switch, see "Setting the Proximity Switches" (Page 40)
Valve does not open at vacuum pressure	Valve seat and valve disk stick together	Check and clean valve seat + valve disk
	Valve disk is blocked mechanically	Remove the blockage

Maintenance

Inspections

Between the maintenance periods, the valves must be checked for leakage and proper function.

Product Contact Seals

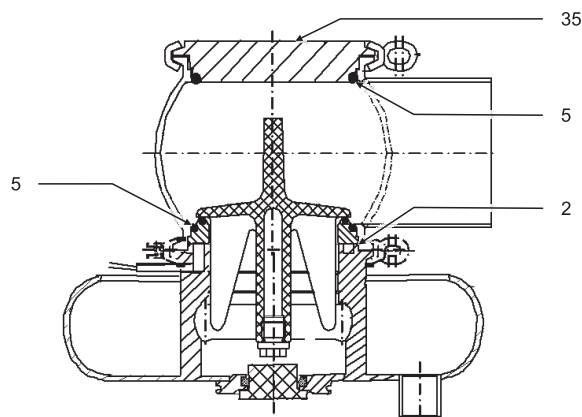

Carry out the following steps:

- Regularly check:
 - O-rings (5) in the cover (35) and seat (2)
 - Seal in the seat (2)
 - Set screw condition
 - Earth cable connection

✓ Done

Pneumatic Connections

Carry out the following steps:

1. Check the operating pressure at the pressure reducing and filter station.
2. Regularly clean the air filter in the filter station.
3. Check that the air hoses sit firmly in the air connections.
4. Check the lines for kinks and leaks.

✓ Done

Electrical Connections

Carry out the following steps:

1. Check that the cap nut on the proximity switch is firmly secured.
2. Check the cable connections on the heater and on the proximity switch.
3. Check the earth cable connection.

✓ Done

Maintenance Intervals

To ensure the highest operational reliability of the valves, all wearing parts should be replaced at longer intervals.

The actual maintenance intervals can only be determined by the user since they depend on the operating conditions, for instance:

- daily period of use,
- switching frequency,
- type and temperature of the product,
- type and temperature of the cleaning solution,
- ambient conditions.

Maintenance Intervals

Applications	Maintenance Intervals (guideline values)
Media at temperatures of 60 °C to 130 °C 140 °F to 266 °F	approx. every 3 months
Media at temperatures of < 60 °C (< 140 °F)	approx. every 12 months

Removing the Valve

Requirement

- Make sure that during maintenance and repair work no process is in operation in the area concerned.

Carry out the following steps:

1. Drain all pipe system elements that lead to the valve and, if necessary, clean or rinse them.
2. Shut off the control air supply.
3. Disconnect the power supply.
4. Take the valve, with all housings and housing connections if possible, out of the pipe section.

✓ Done

Disassembling the Valve

Type V... Without Feedback

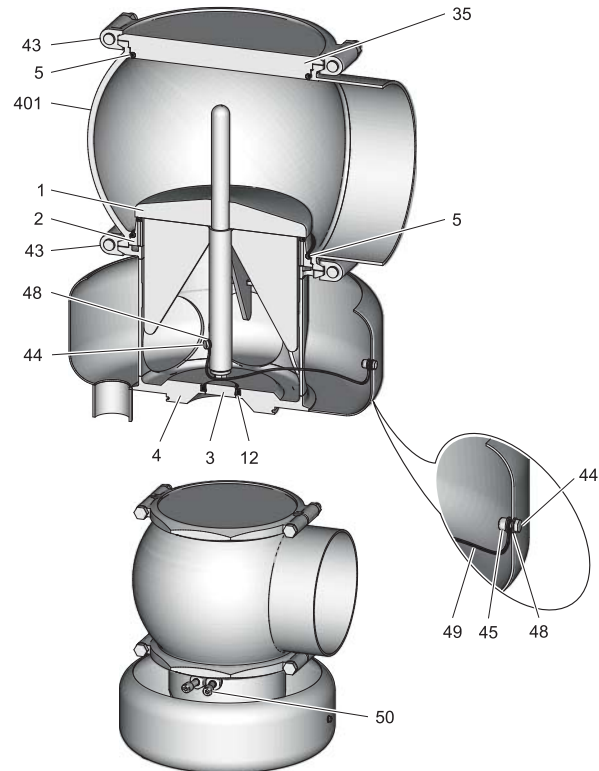

Type V... without feedback

IMPORTANT NOTE

Valve disk (1) and seat (2) are loose once the clamp joints (43) have been released.

They can get damaged when being pulled out.

→ Carefully pull the valve parts out of the housing (401) from the bottom.

Carry out the following steps:

1. Remove the cap V (3).
2. Unscrew earth cable on drip pan (44,45,48,49)
3. Unscrew the 4 set screws (50)
4. Loose clamp joints (43).
! Specify clamp joint (43) of blanking plate (35).
5. Pull out VAK housing (4)

6. Pull out the valve disc (1)



Type V...E With Feedback

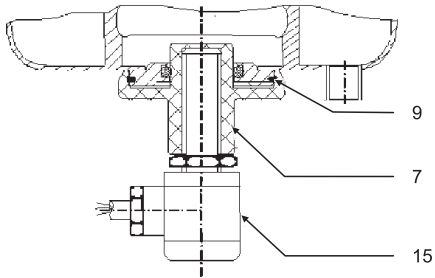

Carry out the following steps:

- Press the snap ring (9) together and pull off the proximity switch mounting (7).



Type V...A With Lifting Actuator

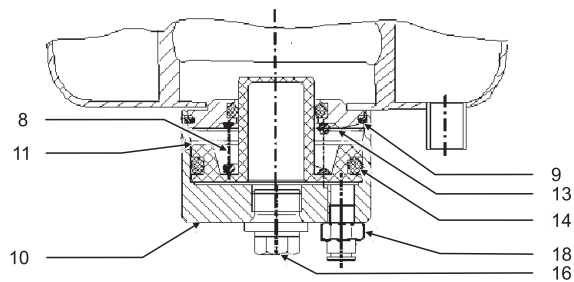

Carry out the following steps:

- Press the snap ring (9) together and pull off cylinder V (10).



Type V...R With Lifting Actuator and Feedback

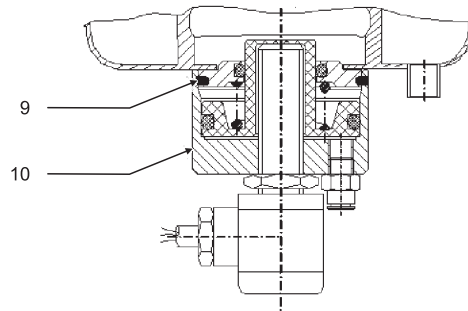

Carry out the following steps:

➔ Press the snap ring (9) together and pull off cylinder V (10).



Maintenance

Cleaning the Valve



CAUTION

Cleaning agents spraying out due to excess pressure in the container to be cleaned

If the container to be cleaned is under excess pressure, the pressure is released into the atmosphere during lifting. If this happens during cleaning, when cleaning solution is continuously sprayed into the valve housing, the air flowing out carries the cleaning solution along. This liquid can spray out of the collecting pan for the vacuum pan. Depending on the level of the excess pressure, a considerable amount of cleaning solution can emerge. These effects are physical and cannot be avoided.

- Use the lifting function only when the container is not under pressure.
- Lift the pressure relief valve disk before lifting the vacuum valve disk, in order to reduce spraying if a residual overpressure exists.
- Use the lifting function only when the collecting pan for the vacuum valve is empty.

IMPORTANT NOTE

Valve disk, housing seat and valve seat are precision parts.

Damage to these parts can result in malfunctions.

- Handle the valve with care!

IMPORTANT NOTE

Damage to the valve

Damage to the valve can result in a malfunction.

- Observe the safety information sheets issued by the detergent manufacturers!
- Only use detergents which are non-abrasive and not aggressive towards stainless steel.

Carry out the following steps:

1. Disassemble the valve, see "Disassembling the Valve" (Page 31).
2. Carefully clean the individual parts.

✓ Done

Replacing Wearing Parts

Carry out the following steps:

1. Replace the O-rings (5) on seat.

! PTFE-O-Ring within Seat (2) must not be changed.
 Seat with PTFE-O-Ring is one item and a spare part: 221-468.11.

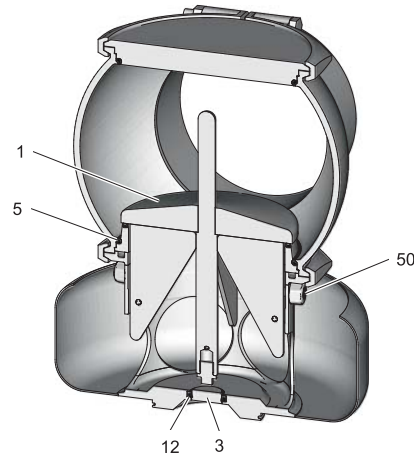

2. Replace the O-ring (12) on the vacuum housing.
3. Replace the set screws (50).
4. Replace snap ring (9) in valves with seat lifting.

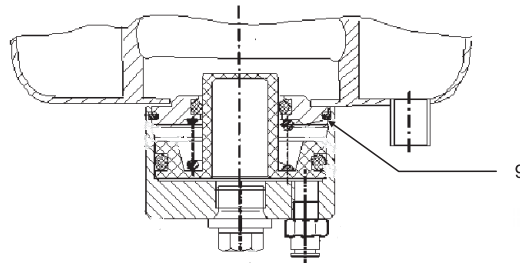

5. Remove the heater from the vacuum housing.
6. Replace defective seals, but always fit new housing O-rings to ensure the tightness of the valve. Always use original spare parts.

✓ Done

NOTE

Used seals must not be used again, since the proper function of the seal can no longer be ensured.

Lubricating Seals and Threads



CAUTION

Damage to seals and threads

Damage to seals and threads can result in a malfunction.

- Ensure that an adequate film of lubricant is applied.
- For product contact seals only use suitable greases and oils.
- Observe the safety information sheets issued by the lubricant manufacturer!

Carry out the following steps:

1. Lubricate all screw threads.
2. Apply a fine film of lubricant to all seals.

✓ Done

NOTE

GEA Tuchenhagen recommends Rivolta F.L.G. MD-2 and PARALIQ GTE 703. These lubricants are approved for foodstuff and are resistant to beer froth. They have the NSF-H1 (USDA H1) registration. PARALIQ GTE 703 can be ordered from GEA Tuchenhagen under part no. 413-064, and Rivolta F.L.G. MD-2 can be ordered under part no. 413-071.

Using other types of grease can result in malfunctions or in premature seal failure. The warranty will also become null and void.

A Manufacturer's Declaration for these products can be obtained from GEA Tuchenhagen if required. A thin film of grease is required on the seals to ensure the proper function of the fittings. It reduces friction and extends the service life of the seals. This is absolutely harmless from a health and hygienic point of view.

Running dry must be avoided!

Assembling the Valve

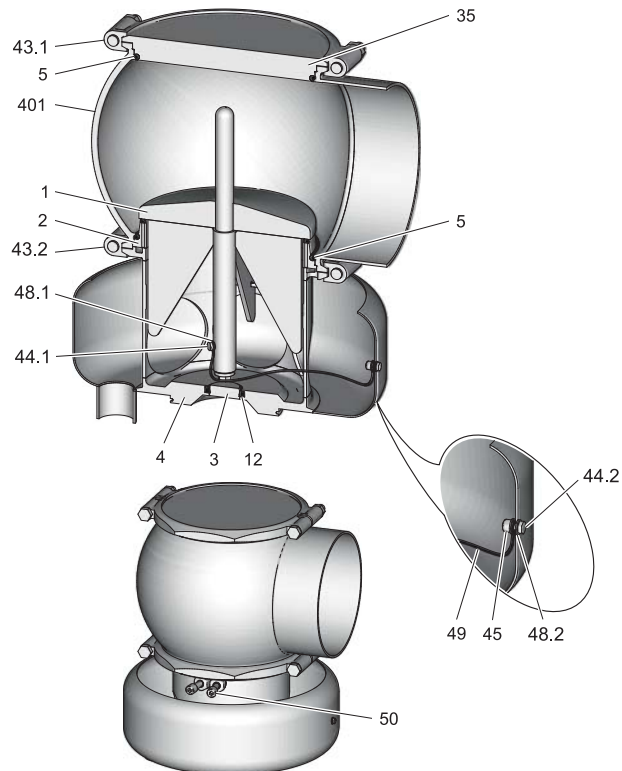

Valve V / Ex-S 6"IPS / 20

Carry out the following steps:

1. Screw earth cable (49) on valve disk (1, 44.1, 48.1)

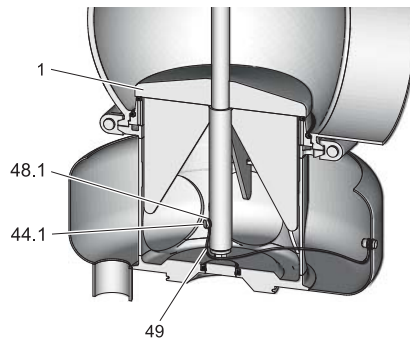

2. Fit O-ring (5) into seat (2).

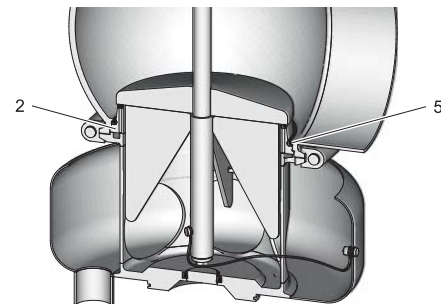

3. Fit O-ring (12) and cap (3) into housing (4).

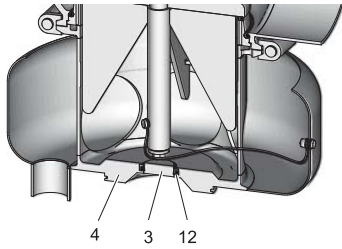

4. Place seat (2) on housing (4).

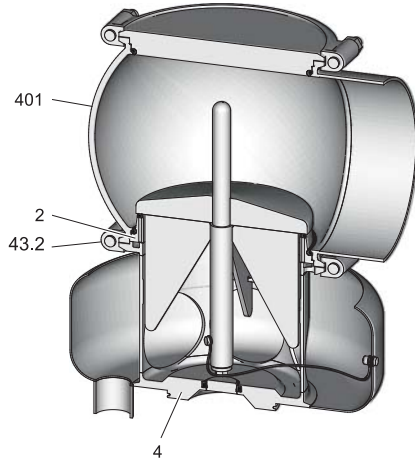

5. Place housing (401) on seat (2)

6. Fit clamp joint (43.2).

! Make sure the clamp joint (43.2) is firmly secured.

7. Screw earth cable (49) on drip pan (44.2, 45, 48.2)

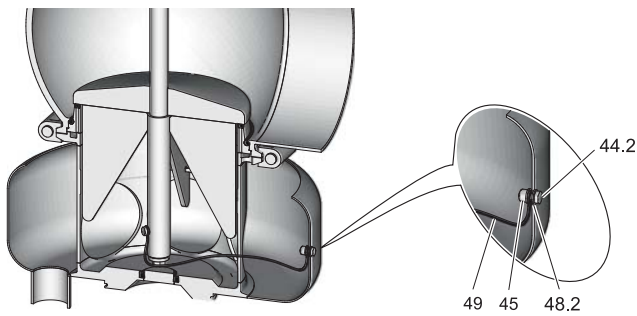

8. Screw the 4 set screws (50).



9. Fit O-ring (5) into blanking plate (35).

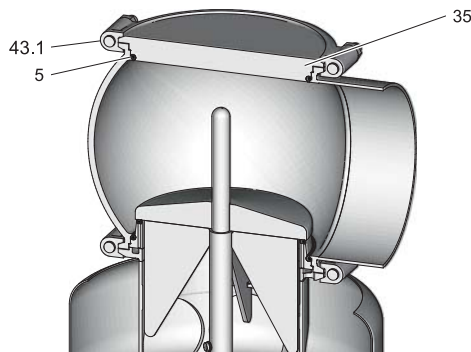

10. Fit clamp joint (43.1).

! Make sure the clamp joint (43.1) is firmly secured.



Torques for the Cast Clamps and Clamp joints

Carry out the following steps:

➔ Tighten the clamp joints and clamps on the valve to the torques specified in the table.

Torques to be set

Torques		Nm	lbft
Clamp joints Cast clamps	M6	9	6.6
Clamp joints Cast clamps	M8	22	16.2
Cast clamps	M10	45	33

Setting the Proximity Switches

Vacuum Valve with Lifting Actuator Type V...R

IMPORTANT NOTE

Sensitive parts

The piston can be slightly deformed when the proximity switch is fitted.

→ Pay attention when screwing in the proximity switch (15) that the piston (11) of the lifting actuator is not deformed.

Carry out the following steps:

1. Screw in the proximity switch (15) as far as it will go (A).

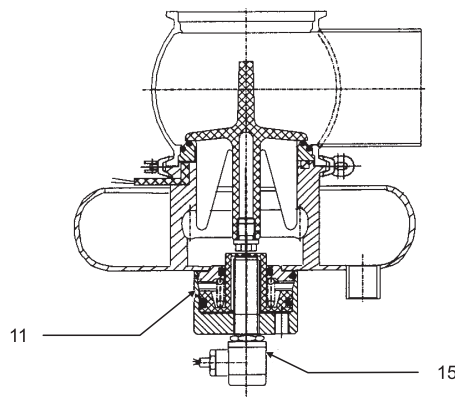

2. Secure the proximity switch (15) using a hex. nut (15.1).

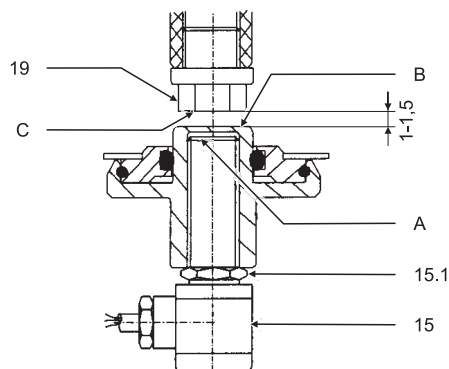

→ After securing the proximity switch (15), there must be a gap of 1 to 1.5mm between areas (B) and (C) on the screw (19). If the gap is smaller or larger than 1 to 1.5mm, the screw (19) must be adjusted.

✓ Done

Vacuum Valve with Lifting Actuator Type V...E

IMPORTANT NOTE

Sensitive parts

The front of the proximity switch mounting can be damaged when the proximity switch is fitted.

→ Pay attention when screwing in the proximity switch (15) that the piston (11) of the lifting actuator is not deformed.

Carry out the following steps:

1. Screw in the proximity switch (15) as far as it will go (A).

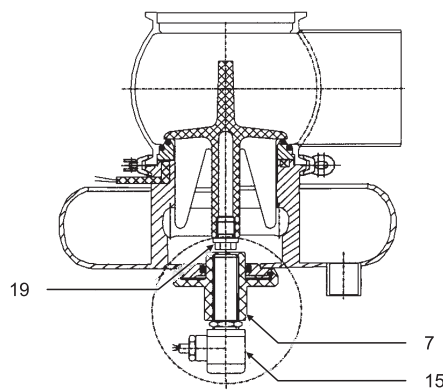

2. Secure the proximity switch (15) using a hex. nut (15.1).

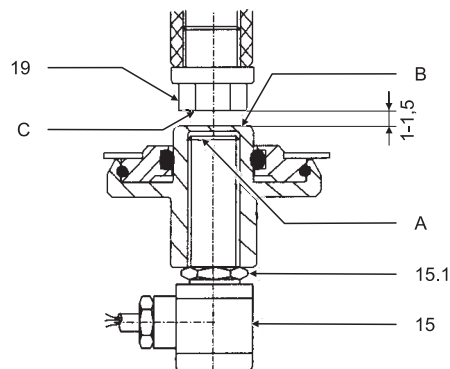

→ After securing the proximity switch (15), there must be a gap of 1 to 1.5mm between areas (B) and (C) on the screw (19). If the gap is smaller or larger than 1 to 1.5mm, the screw (19) must be adjusted.

✓ Done

Disposal

Dispose of the machine at the end of its life cycle in an environmentally friendly manner. Observe the statutory waste disposal regulations applicable at the place of installation.

The valve is made of the following materials:

- Metals
- Synthetic materials
- Electronic parts
- Lubricants containing oil and grease

Separate the different materials and dispose of them correctly sorted. Also observe the instructions regarding disposal in the operating instructions for the individual components.

Technical Data

Type Plate

The type plate clearly identifies the valve.

Made by GEA Tuchenhagen			
Type	VLR-DN65-BM-L0-12N/52		
Serial	1229556/0010		
Mat.	1.4404 (AISI 316L)/EPDM (FDA)		
Air bar/psi	min. 4.0 / 58	max. 8.0 / 116	
PS bar/psi	1 6.0 / 87	2 xxx / xxx	3 xxx / xxx

Type plate of the valve

The type plate provides the following key data:

Key data of the valve

Type	Vacuum valve VLR
Serial	Serial number
Material	1.4404 (AISI316L)/PTFE (FDA)
Control air pressure bar/psi	min. 4.0 (58); max. 8.0 (116)
Product pressure bar/psi	6.0 (87)

Technical Data

Refer to the following tables for the key technical data of the valve:

Technical data: Valve

Designation	Description
Size	6" IPS
Material of product contact parts	Stainless steel 1.4404 Polysulfone Check corrosion resistance with respect to media and detergents
Installation position	Vertical
Heating wire	Power 20 W Voltage 24 V AC Switching the power supply for heating on/off must be controlled externally.

Technical data: Ambient temperatures

Designation	Description
- Valve	0 to 45 °C, standard < 0 °C: use control air with a low dew point. Protect valve stems against freezing.
- Proximity switch	-20 to +80 °C
Product temperature and operating temperature	Depending on the sealing material max. 100 °C

Technical data: Compressed air supply

Designation	Description
Air hose	
- Metric	Material PE-LD Outside dia. 6 mm Inside dia. 4 mm
- Inch	Material PA Outside dia. 6.35 mm Inside dia. 4.3 mm
Product pressure	6 bar (87 psi) standard
Control air pressure	6 bar (87 psi) max. 10 bar (145 psi)
Control air	acc. to ISO 8573-1:2010
- Solid particle content:	Quality class 6 Particle size max. 5µm Particle density max. 5 mg/m ³
- Water content:	Quality class 4 max. dew point +3 °C If the unit is used at higher altitudes or at low ambient temperatures, the dew point must be adapted accordingly.
- Oil content:	Quality class 3, preferably oil free max. 1mg oil in 1m ³ air

Resistance of Sealing Materials

The resistance of sealing materials depends on the type and temperature of the medium conveyed. The exposure time can adversely affect the service life of the seals. The sealing materials comply with the regulations of FDA 21 CFR 177.2600 or FDA 21 CFR 177.1550.

Resistance:

- + = good resistance
- o = reduced service life
- – = not resistant

Table Resistance of Sealing Materials

Medium	Temperature	Sealing material (general operation temperature)			
		EPDM -40...+135°C -40...+275°F	FKM -10...+200 °C +14...+392°F	HNBR -25...+140 °C -13...+284°F	PTFE
Caustics up to 3%	up to 80 °C (< 176°F)	+	o	+	+
Caustics up to 5%	up to 40 °C (< 104°F)	+	o	o	+
Caustics up to 5%	up to 80 °C (< 176°F)	+	–	–	+
Caustics at more than 5%		o	–	–	+
Inorganic acids up to 3%	up to 80 °C (< 176°F)	+	+	+	+
Inorganic acids up to 5%	up to 80 °C (< 176°F)	o	+	o	+
Inorganic acids up to 5%	up to 100 °C (< 212°F)	–	+	–	+
Water	up to 80 °C (< 176°F)	+	+	+	+
Steam	up to 135 °C (< 275°F)	+	o	o	+
Steam approx. 30 min	up to 150 °C (< 302°F)	+	o	–	+
Fuels/hydrocarbons		–	+	+	+
Product with a fat content of max. 35%		+	+	+	+
Product with a fat content of more than 35%		–	+	+	+
Oils		–	+	+	+

* depending on the installation position

Pipe Ends

Dimensions for Pipes in Inch IPS

Inch IPS	Outside diameter	Wall thickness	Inside diameter	Outside diameter acc. to DIN EN ISO 1127
6"	168.3	2.77	162.76	x

Tools

Tool	Part no.
Hose cutter	407-065
Open end spanner, a/f 13-15	408-035
Open end spanner, a/f 14-17	408-045
Open end spanner, a/f 22-24	408-040

Lubricants

Lubricants	Part no.
Rivolta F.L.G. MD-2	413-071
PARALIQ GTE 703	413-064

Weights

Size	Weight (kg)
6" IPS	approx. 20

Spare Parts Lists

Vakuumventil V

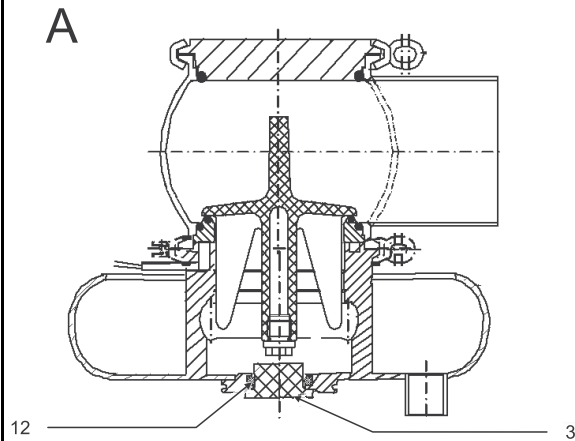
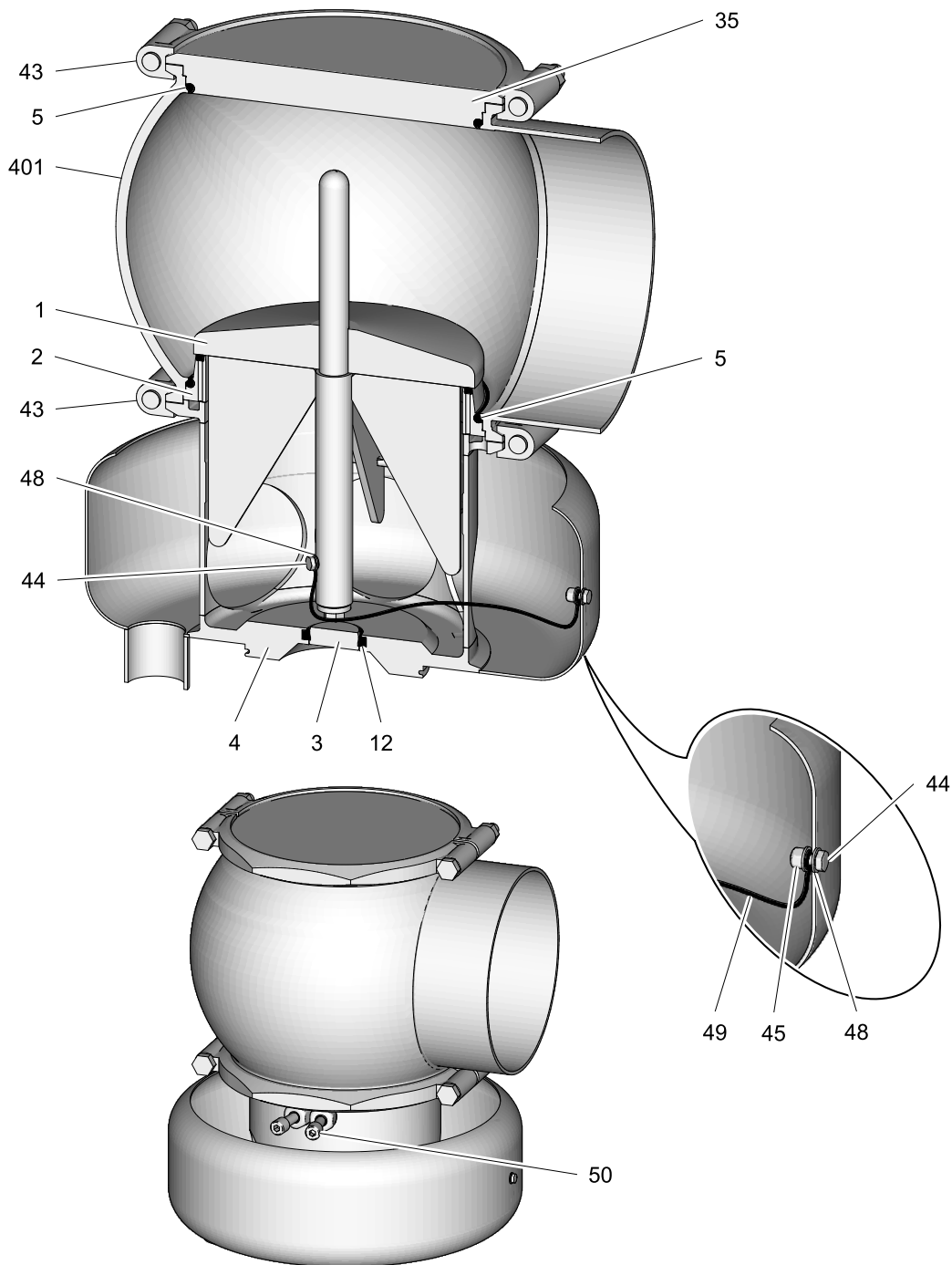

Fig. A: Type V... without lifting; without feedback

Part nos. of spare parts for inch IPS sizes

Item	Designation	Material	6" IPS
3	Cap V	RCH 1000	221-256.06
12	O-ring	NBR	930-039

Vacuum Valve V / Ex-S 6"IPS / 20





Item	Designation	Material	6" IPS
1	Valve disk VAK/Ex-S 6"IPS/20	1.4404	221-253.31
2	Seat V/Ex-S/kpl. 6"IPS/20	1.4301/PTFE	221-468.11
3	Cap V30	--	221-256.06
4	Housing VAK/Ex-S/kpl. 6"IPS/20	1.4301	221-590.07
5	O-ring 158x5	E7502	930-260
12	O-ring 27x5	NBR	930-039
35	Blanking plate N	--	221-144.05
43	Clamp joint GU	--	221-507.14
44	Hex. screw M4x10	1.4301	901-003
45	Hex. nut self-locking	A2	910-112
48	Disk A-4,3/9x0,8	A2	921-005
49	Wire 1ADER/1,5 KSH-KSH M4/170	--	221-358.31
50	Set screw VAK/Ex-S/kpl. M12	--	221-005138
401	Housing V1	1.4404	221-101.17

Dimension Sheet

Vacuum Valve V

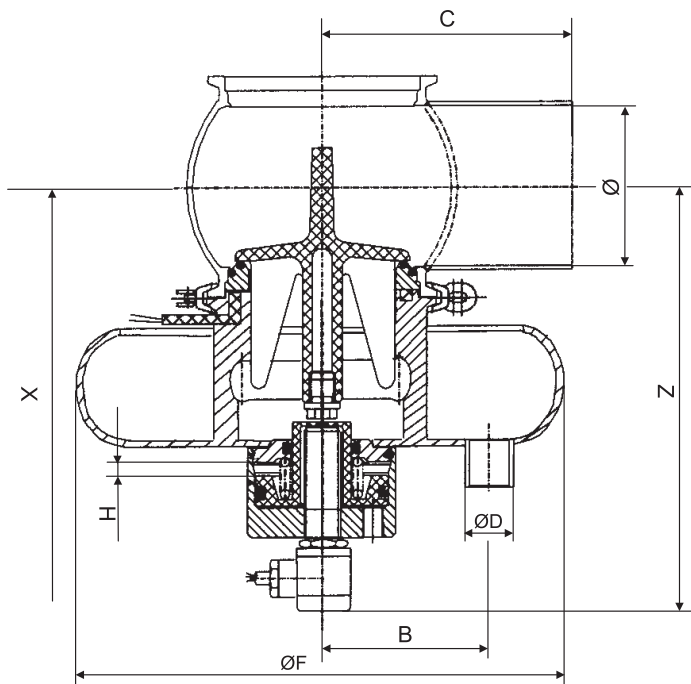

Dimensional drawing: X – installation dimension, H – stroke

Dimension	6" IPS
Ø	162
B	102
C	152,5
ØD	35
ØF	285
X	430
Z	305
Stroke with disk	3
Stroke without disk	6



We live our values.

Excellence · Passion · Integrity · Responsibility · GEA-versity

GEA Group is a global engineering company with multi-billion euro sales and operations in more than 50 countries. Founded in 1881, the company is one of the largest providers of innovative equipment and process technology. GEA Group is listed in the STOXX® Europe 600 index.

GEA Mechanical Equipment

GEA Tuchenhagen GmbH

Am Industriepark 2-10, D-21514 Büchen
Tel.: +49 4155 49-0, Fax: +49 4155 49-2423
sales.geatuchenhagen@gea.com, <http://www.tuchenhagen.com>