



UltraClean Valves

GEA Aseptomag® leakage valve type LV

Operating instruction (Translation from the original language)

430BAL012826EN_4

COPYRIGHT

These Operating Instructions are the English translation of the original operating instructions in the sense of the EU Machinery Directive. This document is protected by copyright. All rights reserved. The document may not, in whole or in part, be copied, reproduced, translated or reduced to an electronic medium of machine-readable form without the express permission of GEA Tuchenhagen GmbH.

LEGAL NOTICE

Word marks

Aseptomag® and TEFASEP® are registered trademarks of GEA Aseptomag AG and may not be used without the permission of GEA Aseptomag AG.

T.VIS® is a protected trademark of GEA Tuchenhagen GmbH.

TABLE OF CONTENTS

1	General Information	5
1.1	Information on the Document	5
1.1.1	Binding character of this instruction manual	5
1.1.2	Notes on the Illustrations	5
1.1.3	Symbols and Highlighting	5
1.2	Manufacturer address	6
1.3	Customer service	6
1.4	EC Declaration of Incorporation	7
2	Safety	8
2.1	Intended use	8
2.1.1	Requirements for operation	10
2.1.2	Pressure equipment directive	10
2.1.3	ATEX directive	10
2.1.4	Improper operating conditions	10
2.2	Operator's Duty of Care	10
2.3	Subsequent changes	11
2.4	General safety instructions and dangers	11
2.4.1	Principles for safe operation	12
2.4.2	Environmental Protection	12
2.4.3	Electrical Equipment	12
2.5	Supplementary Regulations	13
2.6	Qualification of personnel	13
2.7	Safety equipment	14
2.7.1	Signs	14
2.8	Residual dangers	14
2.9	Danger zones	16
3	Description	17
3.1	Design of the valve	17
3.2	Valve Identification	18
3.3	Sealing Concepts	20
3.3.1	System "AZ"	20
3.3.2	System "EA"	20
4	Transport and storage	22
4.1	Storage conditions	22
4.2	Transport	22
4.2.1	Scope of supply	22
5	Technical data	23
5.1	Technical data	23
6	Assembly and installation	25
6.1	Safety instructions	25
6.2	Notes on installation	25
6.3	Welding In a Valve with Pipe Connection	25
6.3.1	Welding In and Installing a Valve	25
6.3.2	Welding post-treatment	26
6.4	Pneumatic connections	26
6.4.1	Overview switching positions	26
	Switching positions "AZ"	27
	Overview switching positions "EA"	28
6.4.2	Air requirement	28
6.4.3	Establishing the Compressed Air Supply	29
6.5	Electrical connections	29
7	Start-up	31
7.1	Safety notes	31
7.2	Notes on commissioning	31
8	Operation and control	32
8.1	Safety instructions	32
9	Cleaning	33
9.1	Cleaning	33
9.2	Sterilisation	33

9.3	Passivation	33
10	Maintenance	35
10.1	Safety instructions	35
10.2	Inspections	36
10.2.1	Bellows	36
10.2.2	Pneumatic connections	36
10.2.3	Electrical connections	36
10.3	Servicing intervals	36
10.4	List of tools	38
10.5	Prior to disassembly	43
10.6	Disassembling and Assembling the Valve	43
10.6.1	Removing the valve	44
10.6.2	Assembling the Valve	46
10.6.3	Torques for clamp	47
10.7	Disassembling and Assembling the Internal Assembly	47
10.7.1	Removing the internal assembly "AZ"	47
10.7.2	Installing the internal assembly "AZ"	48
10.7.3	Disassemble internal assembly "EA"	48
10.7.4	Assemble internal assembly "EA"	51
10.8	Disassembling and Assembling the Seals on the Inner Part	52
10.8.1	Disassemble the seals on the inner part "AZ"	52
10.8.2	Disassembling the seals on the inner part AZ	55
10.8.3	Torques for divisible valve discs	58
10.8.4	Removing the EA "shrink-on system" valve seat seal	58
10.8.5	Fitting the EA "shrink-on system" valve seat seal	60
10.8.6	Replacing V-ring top bellows unit "EA"	62
10.8.7	Replacing V-ring bottom bellows unit "EA"	64
10.9	Carrying out the "Internal Assembly" Leak Test (Bubble Test)	66
10.9.1	Bubble test of the top bellows unit	66
10.9.2	Bubble test of the bottom bellows unit	67
10.10	Disassembling and Assembling the Actuator	70
10.10.1	Disassembling Actuator PA80DT - PA180DT	70
10.10.2	Assembling Actuator PA80DT - PA180DT	73
10.10.3	Disassembling the LV/DT actuator PA80EA - PA255EA	75
10.10.4	Fitting the LV/DT actuator PA80EA - PA255EA	77
10.11	Maintenance	78
10.12	Checking the Feedback Unit	79
10.12.1	Setting the Feedback Unit	79
10.12.2	Valve stroke	80
11	Alarms	81
11.1	Malfunctions and remedies	81
12	Decommissioning	83
12.1	Safety instructions	83
12.2	Disposal	83
12.2.1	General notes	83
13	Appendix	84
13.1	Lists	84
13.1.1	Abbreviations and terms	84

1 General Information

1.1 Information on the Document

The present Operating Instructions are part of the user information for the product. The Operating Instructions contain all the information you need to transport, install, commission, operate and carry out maintenance for the product.

1.1.1 Binding character of this instruction manual

This instruction manual contains the manufacturer's instructions to the operator of the component and to all persons who work on or use the component regarding the procedures to follow.

Carefully read this instruction manual before starting any work on or using the component. Your personal safety and the safety of the component can only be ensured if you act as described in the instruction manual.

Store the instruction manual in such a way that it is accessible to the operator and the operating staff during the entire service life of the component. When the location is changed or the component is sold make sure you also provide the instruction manual.

1.1.2 Notes on the Illustrations

The illustrations in these Operating Instructions show the product in a simplified form. The actual design of the product can differ from the illustration. For detailed views and dimensions of the product please refer to the design documents.

1.1.3 Symbols and Highlighting

In these Operating Instructions, important information is highlighted by symbols or special formatting. The following examples illustrate the most important types of highlighting.



Danger

Warning: Fatal Injuries

Failure to observe the warning can result in serious damage to health, or even death.

- ▶ The arrow identifies a precautionary measure you have to take to avoid the hazard.



Warning: Explosions

Failure to observe the warning can result in severe explosions.

- ▶ The arrow identifies a precautionary measure you have to take to avoid the hazard.
-

 **Warning!**

Warning: Serious Injuries

Failure to observe the warning can result in serious damage to health.

- ▶ The arrow identifies a precautionary measure you have to take to avoid the hazard.

 **Caution!**

Warning: Injuries

Failure to observe the warning can result in minor or moderate damage to health.

- ▶ The arrow identifies a precautionary measure you have to take to avoid the hazard.

Notice

Warning: Damage to Property

Failure to observe the warning can result in serious damage to the component or in the vicinity of the component.

- ▶ The arrow identifies a precautionary measure you have to take to avoid the hazard.

Carry out the following steps: = Start of a set of instructions.

1. First step in a sequence of operations.
 2. Second step in a sequence of operations.
 - Result of the previous operation.
- The operation is complete, the goal has been achieved.

 **Hint!**

Further useful information.

1.2 Manufacturer address

GEA Aseptomag AG
Industrie Neuhof 28
CH-3422 Kirchberg

1.3 Customer service

Phone: +41 (0)34 426 29 29
Fax: +41 (0)34 426 29 28
service.aseptomag@gea.com
www.gea.com

1.4 EC Declaration of Incorporation



Kirchberg, 17.12.2020

Declaration of Incorporation

According 2006/42/EC from 09.06.2006, appendix II B

INCORPORATION OF PARTLY COMPLETED MACHINERY

We herewith declare that the subsequently described partly completed machine complies with the below listed essential requirements of the machine directive 2006/42/EC. The technical documentation is compiled in accordance with part B of Annex VII. In response to reasonable request the relevant technical documentation will be provided to the national authorities in printed or electronic format (PDF).

Manufacturer:	GEA Aseptomag AG Industrie Neuhof 28 CH-3422 Kirchberg
Authorized person:	GEA Aseptomag AG Aron Stauffer Industrie Neuhof 28 CH-3422 Kirchberg
Commercial name of the machine:	Valve
Machine type:	Aseptomag® Valve Technology
Serial number:	xxxx yy (x = serially numbered, y = year of manufacture)
Respective EC standard:	2006/42/EC
Essential requirements:	Appendix I, section 1 and 2.1
Applied harmonized standards:	DIN EN ISO 12100:2010

The commissioning of this partly completed machine is prohibited until the final machinery into which it is to be incorporated has been declared in conformity with the provisions of the Machine Directive 2006/42/EC.



Dirk Dubiel
Management Board
GEA Aseptomag AG



i.A. Aron Stauffer
Teamleader Engineering

GEA Aseptomag AG
Tel. +41 34 426 29 29 · Fax +41 34 426 29 28 · gea.com
Industrie Neuhof 28, CH-3422 Kirchberg

Page 1 of 1

2 Safety

2.1 Intended use

UltraClean Leakage Valves of type LV are mix-proof stroke valves for process systems and permit the safe separation of incompatible media. The media separation is carried out in the integrated leakage chamber that is limited to both product lines with one seal for each line. Any leakage at the sealing elements is diverted through the side valves.

For safe operation, it is mandatory that the following points are observed in the different process steps:

Home position

Both valve seats are in the closed position. This separates both process lines safely from each other via two seals (one semi-axial and one radial) and the leakage chamber located in-between.

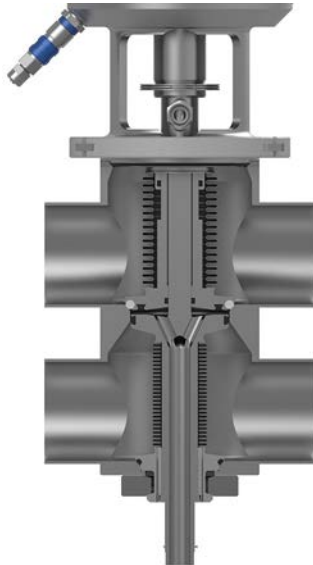

Fig.1: Home position

Transfer

During media transfer through the main valve, the inner part seals the leakage chamber safely against the product by moving the valve seats together.

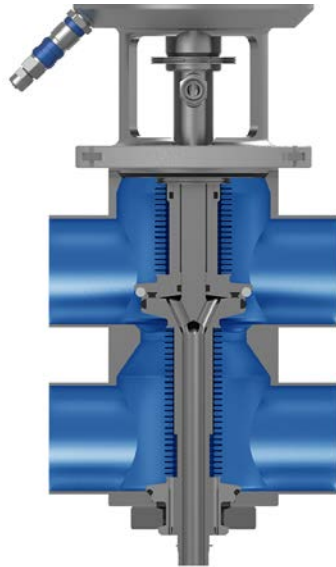

Fig.2: Transfer

CIP cleaning with seat venting

Aseptomag leakage valves LV offer the possibility of seat venting the valve seats (seat A with system "AZ", seat A + B with system "EA"). If the seat venting of a valve seat is activated for a CIP cleaning (preferably in cycles) no process may be running in the opposite line.

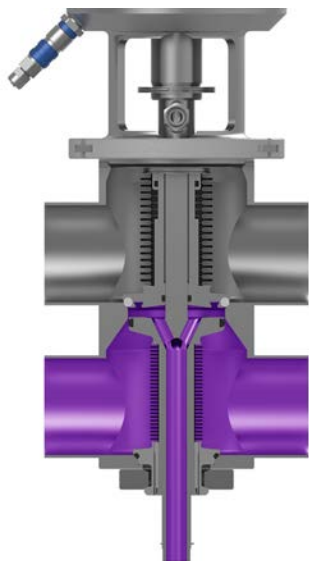

Fig.3: Cleaning valve seat A

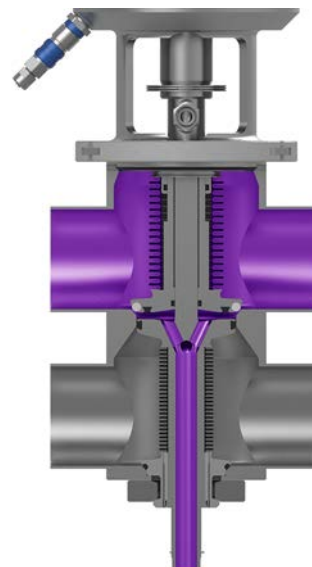

Fig.4: Cleaning valve seat B

Pressure hammers and excessive control air pressure (>8 bar) can damage the bellows. To avoid pressure hammers during opening and closing of the valves, pressureless switching is always recommended.

The valve is monitored, controlled and operated by the customer's installation.



Hint!

The manufacturer will not accept any liability for damage resulting from any use of the valve which is not in accordance with the designated use of the valve. The risk is borne solely by the operating company.

2.1.1 Requirements for operation

The prerequisite for reliable and safe operation of the component is proper transportation and storage as well as professional installation and assembly. Operating the unit within the limits of its designated use also involves adhering to the operating, inspection and maintenance instructions.

2.1.2 Pressure equipment directive

The valve is a piece of pressure equipment (without safety function) as defined in the Pressure Equipment Directive: Directive 2014/68/EG. It is classified according to Annex II, article 4, section 3. In the event of any deviations, GEA Aseptomag AG will supply a specific Declaration of Conformity.

2.1.3 ATEX directive

Aseptomag[®] valve technology can also be used in ATEX protected areas. However, the suitability of the component must be checked under consideration of the respective conditions. Additional information will be made available upon request.

2.1.4 Improper operating conditions

The operational safety of the component can not be guaranteed under improper operating conditions. Therefore avoid improper operating conditions.

The operation of the component is not permitted if:

- Persons or objects are in the danger zone.
- Safety devices are not working or were removed.
- Malfunctions have been detected on the component.
- Damage to the component has been detected.
- Maintenance intervals have been exceeded.

2.2 Operator's Duty of Care

The operating company of the component has a special responsibility for the proper and safe handling of the component within their company. Only use the component when it is in perfect operating condition in order to prevent danger to persons and property.

This operating manual contains information that you and your employees need for safe operation over the life of the component. Be sure to read these Operating Instructions carefully and ensure that the measures described here are observed.

The operator's duty of care includes planning the necessary safety measures and monitoring that these measures are observed. The following principles apply:

- Only qualified personnel may work on the component.
- The operating company must authorize personnel to carry out the relevant tasks.
- Order and cleanliness must be maintained at the work stations and in the entire area surrounding the component.
- Personnel must wear suitable work clothing and personal protective equipment. As the operating company must ensure that work clothing and personal protective equipment are used.
- Inform personnel regarding any properties of the product which might pose a health risk and the preventative measures to be taken.
- Have a qualified first-aid representative on call during the operation. This person must be able to initiate any necessary first-aid measures in case of an emergency.
- Clearly define procedures, competences and responsibilities for those working in the area of the component. Everybody must know what to do in case of an emergency. Instruct the staff in this respect at regular intervals.
- The signs on the component must always be complete and easy to read. Check, clean and replace the signs as necessary at regular intervals.
- Observe the Technical Data specified and the limits of use!



Hint!

Carry out regular checks. This way you can ensure that these measures are actually observed.

2.3 Subsequent changes

You should never make any technical modifications to the valve. Otherwise you will have to undergo a new conformity process in accordance with the EC Machinery Directive on your own.

In general, only original spare parts supplied by GEA Aseptomag AG should be fitted. This ensures the reliable and economical operation of the valve.

2.4 General safety instructions and dangers

The component is safe to operate. It was built according to state-of-the-art science and technology.

Nevertheless, dangers can arise from the component, if:

- the component is not used as intended
- the component is used improperly
- the component is operated under impermissible conditions

2.4.1 Principles for safe operation

Dangerous situations during operation can be avoided by safety-conscious and proactive behaviour of the staff.

To ensure safe operation of the valve the following principles apply:

- The Operating Instructions must be kept ready to hand at the valve's place of use. They must be complete and in clearly legible form.
- Only use the valve for its intended use.
- The valve must be functional and in good working order. Check the condition of the valve before starting work and at regular intervals.
- Wear tight-fitting work clothing for all work on the valve.
- Ensure that nobody can get hurt on the parts of the valve.
- Immediately report any faults or noticeable changes on the valve to the person responsible.
- Never touch the pipes and the valve when these components are hot! Avoid opening the valve unless the process plants have been emptied and depressurised.
- Observe the accident prevention regulations and all local regulations.

2.4.2 Environmental Protection

Harm to the environment can be avoided by safety-conscious and proactive behaviour of the staff.

For environmental protection the following principles apply:

- Substances harmful to the environment must not be discharged into the ground or the sewage system.
- Always observe the pertinent regulations relating to waste avoidance, disposal and utilization.
- Substances harmful to the environment must be collected and stored in suitable containers. Clearly mark the containers.
- Dispose of lubricants as hazardous waste.

2.4.3 Electrical Equipment

For all work on electrical equipment, the following principles apply:

- Access to electrical equipment should only be allowed to qualified electricians. Always keep unattended switch cabinets locked.
- Modifications of the control system can affect the safe and reliable operation. Modifications are only permitted with the express permission of the manufacturer.
- After completion of all work, check that the protective devices are fully functional.

2.5 Supplementary Regulations

In addition to the instructions in this documentation the following also has to be observed:

- pertinent accident prevention regulations,
- generally accepted safety rules,
- national regulations applicable in the country of use,
- work and safety instructions applicable in the facility,
- installation and operating regulations for use in potentially explosive areas.

2.6 Qualification of personnel

This section provides information on how the personnel working on the component must be trained.

Operating and maintenance personnel must

- have the necessary qualification to carry out their tasks,
- be instructed with regard to possible dangers,
- know and observe the safety instructions given in the documentation.

Only allow qualified electricians to carry out work on the electrical equipment or have a qualified electrician supervise the work.

Only allow specially trained personnel to carry out work on an explosion-protected system. When working on explosion-protected equipment observe the standards DIN EN 60079-14 for gases and DIN EN 50281-1-2 for dusts.

The following minimum qualifications are required:

- Training as a specialist for working independently on the component.
- Adequate instruction to work on the component under the supervision and guidance of a trained specialist

Each employee must meet the following requirements to work on the component:

- Personal suitability for the respective task.
- Sufficient professional qualification for the respective task.
- Received instruction about the functionality of the component.
- Received instruction about operating sequences on the component.
- Familiar with the safety devices and their function.
- Familiar with these Operating Instructions, especially with the safety instructions and the information which is relevant for the task on hand.
- Familiar with the basic regulations with regard to occupational health and safety and accident prevention.

When working with the component, a distinction is made between the following user groups:

User groups	
Staff	Qualifications
Operating personnel	<p>Adequate instruction and sound knowledge in the following areas:</p> <ul style="list-style-type: none"> • Functionality of the component • Operating sequences on the pump • What to do in case of an emergency • Lines of authority and responsibilities with respect to the task
Maintenance personnel	<p>Appropriate training and a sound knowledge of the structure and functionality of the component. Sound knowledge in the following areas:</p> <ul style="list-style-type: none"> • Mechanical equipment • Electrical equipment • Pneumatic system <p>Authorization with regard to safety engineering standards to carry out the following tasks:</p> <ul style="list-style-type: none"> • Setting devices into operation • Earthing of devices • Marking of devices <p>The relevant certificates of qualification must be submitted before work can be carried out on ATEX certified machines.</p>

2.7 Safety equipment

2.7.1 Signs

Hazardous locations on the component are marked by warning labels.

The signs and instructions on the component must always be legible. Any illegible signs must be replaced immediately.

Signs on the valve	
Sign	Meaning
	Warning: risk of crushing. Attached on both sides of the lantern.

2.8 Residual dangers

Dangerous situations can be avoided by safety-conscious and proactive behaviour of the personnel and by wearing personal protective equipment.

Residual dangers on the valve and measures		
Danger	Cause	Measure
Danger to life	Inadvertent switch-on of the valve	Effectively disconnect all components, effectively prevent switch-on.
	Electric power	Observe the following safety rules: <ol style="list-style-type: none"> 1. Isolate from the power supply. 2. Take appropriate measures to prevent switch on. 3. Test absence of voltage. 4. Earthing and short-circuiting. 5. Cover or safeguard any adjacent live parts.
Risk of injury	<ul style="list-style-type: none"> • Danger presented by moving or sharp-edged parts • Danger due to escaping media with properties that are dangerous to health 	<p>Effectively prevent unauthorised persons from manipulating the valve. The operator must exercise caution and prudence.</p> <p>For all work:</p> <ul style="list-style-type: none"> • Ensure the controlled dissipation of the leakage volumetric flow. • Wear suitable work clothing. • Never operate the machine if the cover panels are not correctly fitted. • Never open the cover panels during the operation. • Never reach into openings. <p>As a precautionary measure, wear personal protective equipment in the vicinity of the valve:</p> <ul style="list-style-type: none"> • Protective gloves • Safety shoes
Environmental damage	Operating materials with properties which are harmful to the environment	<p>For all work:</p> <ul style="list-style-type: none"> • Collect lubricants and cleaning solutions in suitable containers. • Dispose of lubricants and cleaning solutions in accordance with the pertinent regulations.

2.9 Danger zones

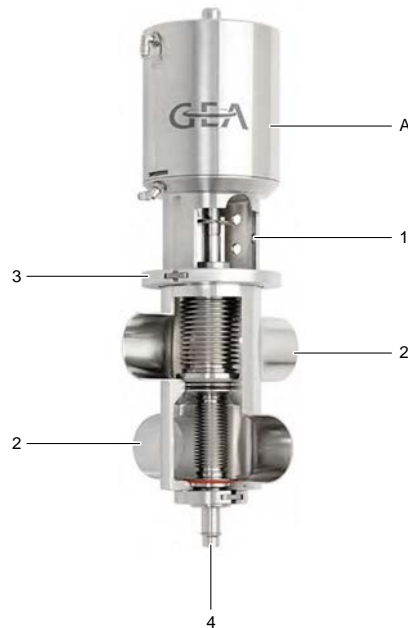

Fig.5: Danger zone at the valve

Please observe the following notes:

- In the event of malfunctions, shut down the valve (disconnect from the power and air supply) and secure it against being used.
- Never reach into the lantern (1) or the valve housing (2) when the valve is switching. There is a danger of injury to fingers.
- With a closed valve there is danger of injury when the clamp (3) is opened since the released closing pressure will suddenly lift the actuator. Therefore, release the closing pressure by opening the valve before detaching the clamp (3) by supplying the actuator (A) with compressed air.
- Particular attention must be paid to the leakage opening (4) as outlet point for media with all leaks or seat venting.
- Before starting any service, maintenance or repair work, disconnect the valve from the power supply and secure it against inadvertently being switched back on again.
- Only allow a qualified electrician to carry out any work on the electrical power supply.
- Check the electrical equipment of the valve at regular intervals. Immediately remedy loose connections and molten cables.
- If work on live parts cannot be avoided, call in a second person, who can operate the main switch in case of an emergency.
- The housing sockets have very sharp edges. When transporting and assembling the valve be sure to wear suitable protective gloves.

3 Description

3.1 Design of the valve

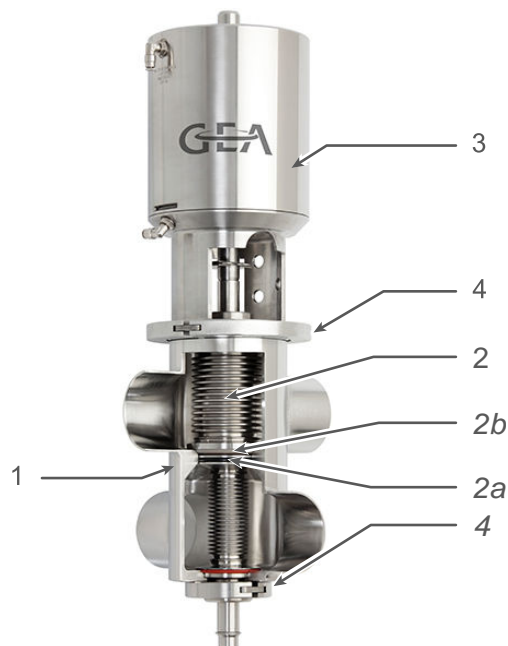

Fig.6: Main components on the valve

Key	
No.	Designation
1	Housing
2	Internal assembly
2a	Valve seat A
2b	Valve seat B
3	Actuator
4	Clamp (safety device)



Hint!

The internal assembly for system "EA" is made up of two sub-assemblies, a lower and an top bellows unit.

3.2 Valve Identification

Reference numbers from the following number systems are assigned to each part of components from GEA Aseptomag AG. The reference numbers can be used to clearly identify a component and its composition.

Number (Example)	Designation	Description
0001 14	Serial valve number	The valve serial number is the easiest and most definite way to identify a component from GEA Aseptomag AG. This number is unique and allows all components installed at the time of delivery to be identified. The first four digits represent a chronological, ascending number, the last two digits provide information about the year of manufacture. The valve's serial number is indicated on a round white sticker affixed to the actuator.
0001 14	Serial number main components	The serial number has the same structure as the valve's serial number, but it is placed on the relevant main component (housing, internal assembly, actuator) by laser marking / stamping.
V-50-1001	Drawing number	The drawing number is a combination of two groups. The digits in front of the hyphen refer to where the components belong to. The next four numbers describe the part in more detail. For this purpose, the main component groups of a valve are assigned to various groups: <ul style="list-style-type: none"> • V-xx-0xxx = entire valves • V-xx-1xxx = valve housings • V-xx-2xxx = internal assemblies • V-xx-3xxx = actuators • V-xx-4xxx = feedback units / accessories

Each of these main components is marked and can be uniquely identified.

! Other markings on components of the valve, such as on connectors, arise from the production process and are not relevant.

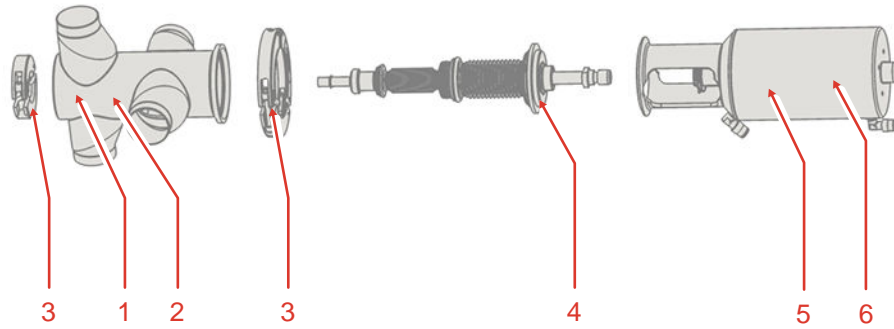

Fig.7: Designations on the valve

Key			
No.	Example	Position	Details
1	V40-1226 1.4435 TC 333937	Valve housing	Drawing number of valve housing Material and re-stamping details
2	0548 10	Valve housing	Serial number of valve housing
3	V25-1006	Top clamp	Number of clamp drawing
	V40-1227	Bottom clamp	
4	V40-2452 1424 10	Internal assembly	Drawing number of internal assembly Serial number of internal assembly
5	1216 10	Actuator	Sticker with valve serial number
6	PA80/25-40 NC 1634N DT V40-3088 0977 10	Actuator	Designation of actuator Number of actuator drawing Serial number of actuator

3.3 Sealing Concepts

3.3.1 System "AZ"

Valve seat seals

TVEP	GEA Aseptomag standard Divisible valve discs, EPDM radial seal (seat A) / PTFE O-ring (seat B)
TVET	GEA Aseptomag option Divisible valve discs, EPDM radial seal (seat A) / TEFASEP O-ring (seat B)

Concept hard and soft sealing

- Divisible valve disk
- For soft seal materials on seat A and for hard seal materials on seat B
- Additional elastomer O-ring behind the valve seat seal A

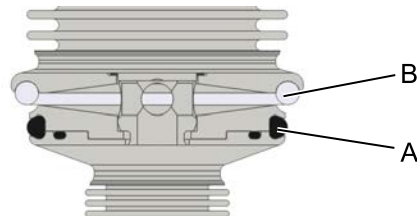

Fig.8: System "AZ" hard and soft sealing

3.3.2 System "EA"

Valve seat seals

VREP	GEA Aseptomag standard V-ring valve disk, EPDM radial seal (seat A) / PTFE O-ring (seat B) / chamber seal EPDM V-ring
VRET	GEA Aseptomag option V-ring valve disk, EPDM radial seal (seat A) / TEFASEP O-ring (seat B) / chamber seal EPDM V-ring

Concept hard and soft sealing

- Undivided valve disc
- For soft seal materials on seat A and for hard seal materials on seat B
- Additional elastomer V-ring for sealing the leakage chamber between seat A and seat B

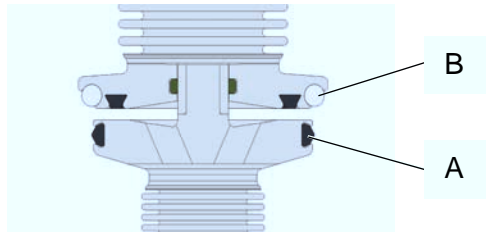

Fig.9: System "EA" hard and soft sealing

4 Transport and storage

4.1 Storage conditions

The valves, valve inserts or spare parts should be stored in a dry place, free of vibrations and dust, and protected from light. To avoid damage, leave the components in their original packaging if possible.

If, during transport or storage, the valve is going to be exposed to temperatures $\leq 0^{\circ}\text{C}$, it must be dried beforehand and suitable measures must be taken to protect it from damage.



Hint!

We recommend that the valve should be stored at a temperature of $\geq 5^{\circ}\text{C}$ for a period of 24 hours prior to any handling (disassembling the housings / activation of actuators) so that any ice crystals formed by condensation water can melt.

4.2 Transport

For transport, the following principles apply:

- Only use suitable lifting gear and slings for transporting the package units/ valves.
- Observe the pictograms on the package.
- Handle valves with care to avoid damage caused by impact or careless loading and unloading. The outside synthetic materials are susceptible to breaking.
- Control tops (if fitted) must be protected from animal and vegetable fats.
- Only allow qualified staff to transport the valve.
- Movable parts must be properly secured.
- Only use approved, fully functional load lifting devices and lifting accessories which are suitable for the intended purpose. Observe the maximum load-bearing capacities.
- Secure the valve against slipping. Take the weight of the valve into account and the position of the point of gravity.
- Under no circumstances should anyone stand under a suspended load.
- Take care when transporting the valve. Do not grip sensitive parts of the unit to lift or push the unit or to support yourself. Avoid putting the unit down with a jerk.

4.2.1 Scope of supply

On receipt of the valve check whether

- the details on the main valve components correspond to the data in the order and delivery documents,
- the equipment is complete and all components are in good order.

5 Technical data

5.1 Technical data

Operating data (for valve with sealing materials PTFE and EPDM)	
Max. operating temperature	130 °C (266 °F)
Max. sterilisation temperature	130°C (266 °F) for max. 30 min.
Max. product pressure	5 ... 6 bar (others on request)
Control air pressure, actuator	6 bar, max. 8 bar
Nominal pressure	10 bar

Materials	
Parts in contact with product	1.4404 (AISI 316L) 1.4435 (AISI 316L) 1.4571 (AISI 316TI)
Actuator (exterior area)	1.4301 (AISI 304) 1.4305 (AISI 304)
Valve seat seal (product-contacting)	TEFASEP PTFE EPDM
Seal (product-contacting)	EPDM
Other materials in accordance with the valve specification.	

Surface finish	
Inside areas in contact with product	Surface roughness $R_a \leq 0.8 \mu\text{m}$ (standard)
Outer surfaces	Metal blank fine turned and/or polished
Inside areas (with the exception of the metal bellows) in contact with product can be electropolished/passivated or ground on request. These methods will bring up surface roughness to $R_a \leq 0.6 \mu\text{m} / 0.4 \mu\text{m}$.	

Resistance of sealing materials	
Product contact seals	All sealing materials in the product contact area are suitable for applications in the food industry. The durability of the sealing materials depends on the type, temperature and contact time of the conveyed media. The final assessment of the suitability of the material is therefore the sole responsibility of the plant operator, even if the materials meet all common guidelines of the food industry (for further information see material certificates).

Technical data

Compressed air supply	
Compressed air supply	6 bar, compressed air filtered (at least 0,5 µm), oil-free.

Cleaning	
Cleaning	The valve is suitable for CIP cleaning (Cleaning in Place)
Recommended cleaning speed in the valve	At least 2 m/s

Sterilisation	
Sterilisation	The valve is suitable for SIP sterilisation (Sterilisation in Place)
Sterilisation with	Hot water at maximum 130 °C (266 °F) for 20 to 30 min. Steam at maximum 130 °C (266 °F) for 20 to 30 min. Chemicals (e.g. H ₂ O ₂)

6 Assembly and installation

6.1 Safety instructions

Hazardous situations during installation can be avoided by safety-conscious and proactive behaviour of the personnel.

For installation, the following principles apply:

- Only qualified personnel are allowed to set-up, install and commission the component.
- Ensure that adequate working and traffic areas are available at the place of installation.
- Observe the maximum load-bearing capacity of the installation surface.
- Observe the transport instructions and markings on the part(s) to be transported.
- Remove any nails protruding from transport crates immediately after opening the crate.
- Under no circumstances should anyone stand under a suspended load.
- Safety devices of the component may not work effectively during installation.
- Reliably secure sections of the plant which have already been connected against inadvertently being switched on.

6.2 Notes on installation

The valve must be installed so that the housing can drain on its own.

To prevent damage, make sure that:

- the valve is installed in the pipe system free of tension and
- no foreign materials (e.g. tools, bolts, lubricants) are left in the system.
- the valve is ideally installed in vertical position.

6.3 Welding In a Valve with Pipe Connection

6.3.1 Welding In and Installing a Valve

This section describes how you weld in a valve with pipe connection.

Prerequisite:

- For valves with welding ends: Actuator and internal assembly have been removed, see Section 10.6, Page 43.

Caution!

Danger of injury due to spring force being released

You can sustain injuries to your fingers when you put your hand into a valve if the valve has not been moved to the open position beforehand.

- ▶ Before starting any work, bring the valve to the "open" position.
 - ▶ Wear protective gloves for all work.
 - ▶ Always exercise caution and prudence.
-

 **Caution!**

If pipes contain liquids, these can spurt out when the pipes are opened.

Danger of injury as a result of hot or aggressive liquids.

- ▶ Drain all pipe system elements that lead to the valve location and, if necessary, clean or rinse them.
 - ▶ Separate the pipe section in which the valve is to be fitted from the rest of the piping system to prevent medium from entering again.
-

Carry out the following steps:

1. Saw the pipe ends flat and square, deburr and degrease them.
2. Prepare the component housing so that the component housing can be welded into position free from stress and distortion.
3. Prepare the welding procedure: use the 141 TIG (tungsten inert gas) welding method with butt weld. I-joint according to DIN8532; hand or orbital weld.
4. Connect the forming gas.
5. Tack the component housing at several points distributed around the circumference under forming gas (ensure forming gas supply).

! Adjoining welding ends must not be separated by a gap. Otherwise the corrosion resistance of the welded joint and the pipe will be reduced when forming gas flows out.

6. Weld the housing into the pipe system.
- The valve has been welded in and installed.

6.3.2 Welding post-treatment

Interior

As long as forming and welding were carried out professionally, post-treatment of the interior surfaces is not necessary.

Exterior area

Depending on the requirements, post-treatment in the exterior area consists of:

- pickling,
- grinding,
- brushing,
- polishing.

6.4 Pneumatic connections

6.4.1 Overview switching positions

6.4.1.1 Switching positions "AZ"

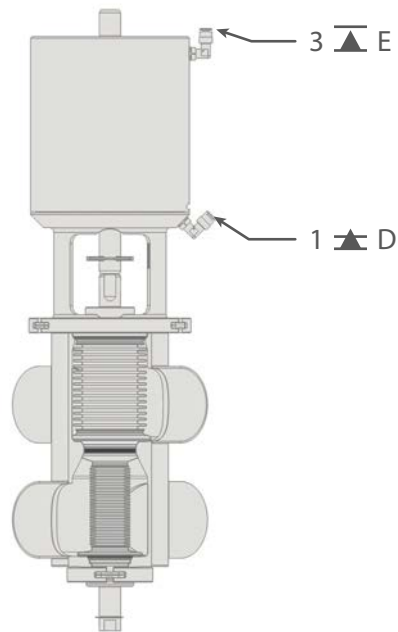

Fig.10: Air connections valve version "AZ"

Function	Valve seat	Air connection	
Open	"A" + "B"	1 ▲	"D"
Venting	"A"	3 ▲	"E"

→ Information on mounting the valve, see Section 3.1, Page 17.

6.4.1.2 Overview switching positions "EA"

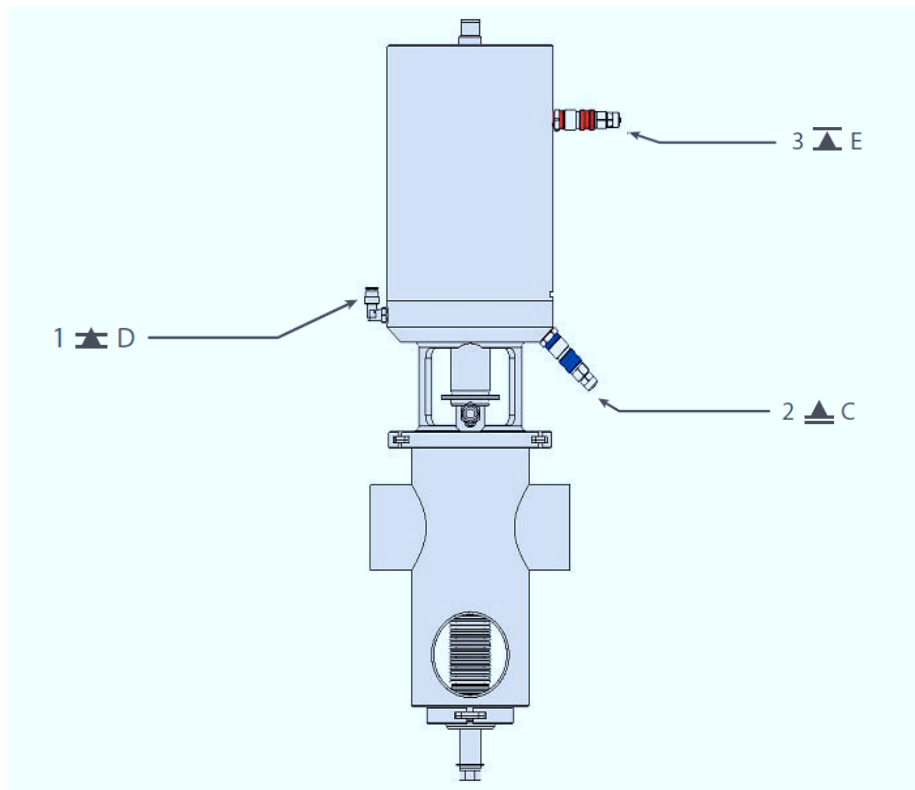

Fig.11: Air connections valve version "EA"

Function	Valve seat	Air connection	
Open	"A" + "B"	1 ▲	"D"
Venting	"A"	3 ▲	"E"
Venting	"B"	2 ▲	"C"

→ Information on mounting the valve, see Section 3.1, Page 17.

6.4.2 Air requirement

The air requirement depends on the type of actuator fitted. The following tables show guideline values at an air pressure supply of 6 bar per valve size and the corresponding actuator size used as a standard.

Air requirement for spring-to-close actuators (AZ)			
Nominal width of valve	Actuator	Air requirements [dm ³]	
		Total stroke	Venting seat A
DN 40 / 1 1/2" OD	PA80 DT	1.0	2.4
DN 50 / 2" OD	PA135 DT	3.7	7.4
DN 65 / 2 1/2" OD	PA135 DT	3.7	7.4
DN 80 / 3" OD	PA180 DT	6.6	12.3
DN 100 / 4" OD	PA180 DT	6.6	12.3

Air requirement for spring-to-close actuators (EA)				
Nominal width of valve	Actuator	Air requirements [dm ³]		
		Total stroke	Venting seat A	Venting seat B
DN25 / 1"OD	PA100 LV/DT EA	3.2	2.9	0.4
DN40 / 1½"OD	PA100 LV/DT EA	3.2	2.9	0.4
DN50 / 2"OD	PA135 LV/DT EA	7.4	5.8	0.8
DN65 / 2½"OD	PA135 LV/DT EA	7.4	5.8	0.8
DN80 / 3"OD	-	-	-	-
DN100 / 4"OD	-	-	-	-

6.4.3 Establishing the Compressed Air Supply

A prerequisite for the reliable operation of the valve is that the compressed air hoses are cut exactly square.

Tools required:

- A hose cutter

Carry out the following steps:

1. Depressurize the pneumatic connection at the place where you are working.
2. Use the hose cutter to cut the pneumatic hoses square.
3. Connect a hose to the valve.

→ The compressed air supply has been established.

6.5 Electrical connections

Prerequisite:

- The valve has been fitted correctly, see Section 10.6, Page 43.



Danger

Live parts

Electrical shock can result in serious personal injury or death.

- ▶ Only allow properly qualified staff to carry out work on the electrical equipment.
- ▶ Prior to establishing electrical connections check the maximum permissible operating voltage.



Explosive gases or dusts

An explosion can result in serious personal injury or death.

- ▶ Observe the installation and operating regulations for use in potentially explosive areas.

Carry out the following steps:

1. Connect in accordance with the control top diagram and the instructions in the corresponding operating instructions for the T.VIS control top or other models.
→ The valve has been connected electrically.

7 Start-up

7.1 Safety notes

Initial commissioning

For initial commissioning, the following principles apply:

- Take protective measures against dangerous contact voltages in accordance with pertinent regulations.
- The component must be fully assembled and properly adjusted. All screw connections must be securely tightened. All electrical cables must be installed correctly.
- Reliably secure machine parts which have already been connected against inadvertently being switched on.
- Relubricate all lubricating points.
- Make sure lubricants are used properly.
- After a modification to the component, a reassessment of residual risks is required.

Commissioning

For commissioning, the following principles apply:

- Only qualified personnel may commission the component.
- Make sure that all connections are functioning properly.
- The safety devices on the component must be completely installed, in working order and function properly. Check the function before starting any work.
- When switching on the component, the danger zones must be clear.
- Remove any liquids that have escaped without leaving residues.

7.2 Notes on commissioning

Before starting commissioning observe the following:

- Make sure that there are no foreign materials in the system.
- Actuate all positions of the valve once by applying compressed air.
- When TEFASEP is used as a sealing material, the valve must be sterilised before the first product run and briefly brought to the closed position immediately after sterilisation to ensure optimum tightness. For detailed information, see Section 9.2, Page 33
- Clean and sterilise the pipe system prior to the first product run.
- During commissioning, regularly check all sealing points for leaks. Replace defective seals.

8 Operation and control

8.1 Safety instructions

Dangerous situations during operation can be avoided by safety-conscious and proactive behaviour of the personnel.

For operation, the following principles apply:

- Monitor the component during operation.
- Safety devices must not be changed, removed or taken out of service. Check all safety devices at regular intervals.
- All guards and hoods must be fitted as intended.
- The installation location of the component must always be properly ventilated.
- Structural changes to the component are not permitted. Report any changes to the component immediately to the person in charge.
- Always keep danger zones clear. Do not leave any objects in the danger zone. Only allow persons to enter the danger zone when the machine is de-energized.
- Regularly check that all emergency stop devices are working correctly.

9 Cleaning

9.1 Cleaning

The valve is suitable for CIP (Cleaning in Place); recommended cleaning speed in the valve is at least 2 m/s.

All parts in contact with product must be cleaned at regular intervals. Always observe the safety data sheets issued by the cleaning agent manufacturers. Only use cleaning agents which do not cause damage to the seals and the inner parts of the valve. When the pipe is cleaned, the cleaning medium also flows through and cleans the valve housings.

With respect to the cleaning method and parameters like detergents, temperatures, times, and intervals, the component manufacturer can merely make recommendations but cannot provide any generally applicable details. Method and parameters should be determined and defined by the operator in accordance with the relevant process and product.

The cleaning effect must be checked regularly by the operator!

9.2 Sterilisation

The valve is suitable for SIP sterilisation (Sterilisation in Place). For valves equipped with the sealing materials PTFE and EPDM, the following specifications apply.

Sterilisation is possible with:

- Hot water at maximum 130 °C (266 °F) for 20 to 30 min.
- Steam at maximum 130 °C (266 °F) for 20 to 30 min.
- Chemicals (e.g. H₂O₂)



Hint!

When TEFASEP valve seat seals are used, hot sterilisation is mandatory. Steam sterilisation allows the seal to be perfectly fitted into the valve seat, thus ensuring optimum sealing against the maximum closing pressure specified.

Operating conditions for steam sterilisation:

- Medium: saturated steam or hot water
- Temperature: >121 °C (250 °F)
- Holding time: 20 ... 30 min

The valve must be placed in the closed position immediately after steam sterilization for a short period (minimum 5 seconds). During commissioning, regularly check all sealing points for leaks. Replace defective seals and repeat the sterilization process.

9.3 Passivation

Before commissioning a plant, passivation is commonly carried out for long pipes and tanks. Valve blocks are usually excepted from this.

Passivation is typically performed using nitric acid (HNO₃) at approx. 80 °C (176 °F) at a concentration of 3 % and a contact time of 6 to 8 hours.

The ultimate temperatures, chemicals, concentrations and contact time to be used must be determined by the plant operator along with its chemical supplier.

10 Maintenance

10.1 Safety instructions

Maintenance and repair

Before carrying out maintenance and repair work on the component's electrical equipment, perform the following steps in accordance with the "5 safety rules":

- Isolate from the power supply
- Take appropriate measures to prevent switch on
- Test absence of voltage
- Earthing and short-circuiting
- Cover or safeguard any adjacent live parts.

For maintenance and repair, the following principles apply:

- Observe the intervals specified in the maintenance schedule.
- Only qualified personnel may carry out maintenance or repair work on the component.
- The component must be switched off and secured against being switched back on before maintenance or repair work. Work may only be started once any residual energy has been discharged.
- Block access for unauthorized persons. Put up notice signs which draw attention to the maintenance or repair work going on.
- Do not climb on the component. Use suitable access aids and working platforms.
- Wear suitable protective clothing.
- Only use suitable and undamaged tools to carry out maintenance work.
- When replacing parts only use approved, fully functional load lifting devices and lifting accessories which are suitable for the intended purpose.
- Before setting the unit back into operation, refit all safety devices as originally provided in the factory. Then check that all safety devices are working correctly.
- Make sure lubricants are used properly.
- Check pipes are firmly secured, also check for leaks and damage.
- Check that all emergency stop devices are working correctly.

Disassembly

For disassembly, the following principles apply:

- Only qualified personnel are allowed to dismantle the component.
- The component must be switched off and secured against being switched back on before it is dismantled. Work may only be started once any residual energy has been discharged.

- Disconnect all power and utility lines.
- Markings, e.g. on lines, must not be removed.
- Do not climb on the component. Use suitable access aids and working platforms.
- Mark the lines (if unmarked) prior to disassembly to ensure they are not confused when re-assembling.
- Protect open line ends with blind plugs against ingress of dirt.
- Pack sensitive parts separately.
- For longer periods of standstill, observe the storage conditions, see Section 4.1, Page 22.

10.2 Inspections

Between the maintenance periods, the components must be checked for leakage and proper function.

10.2.1 Bellows

Carry out the following steps:

1. Check the leakage cavity for soiling and continuous leakage of fluids.
- The bellows has been checked.

10.2.2 Pneumatic connections

Carry out the following steps:

1. Check the operating pressure at the pressure reducing and filter station.
 2. Clean the air filter at regular intervals.
 3. Check that the air hoses sit firmly in the air connections.
 4. Check the lines for kinks and leaks.
- The pneumatic connection has been checked.

10.2.3 Electrical connections

Carry out the following steps:

1. Check that the proximity switches are positioned correctly and the connections are clean.
- The electrical connection has been checked.

10.3 Servicing intervals

To ensure the highest operational reliability of the valve, all wearing parts should be replaced at longer intervals. Keep an adequate supply of all wearing parts (internal assemblies and seals) in your spare parts stock.

In practice, the actual maintenance intervals can only be determined by the user since they depend on the operating conditions.

Examples of relevant process parameters are:

- daily period of use,
- switching frequency,
- type and temperature of the product,
- type and temperature of the cleaning solution,
- ambient conditions.



If information regarding the definition of practical-oriented maintenance intervals is not available or is insufficient, the guideline values listed in the "Maintenance" chapter can be referred. This information is based on empirical values for GEA Flow Components and relates to installations working in two-shift operation.





Hint!

Prior to any work on the open valve, ensure that it has stopped operation, see Section 10.5, Page 43.





10.4 List of tools

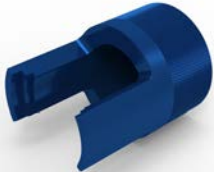

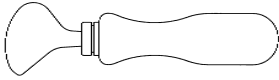

List of tools (in alphabetical order)			
Tool	Figure	Intended Purpose	Material Number GEA Aseptomag AG
Pressurizing tool IT LV "AZ" DN 40 top & bottom		Valves LV & DT DN 40 Inspection of metal bellows	0980.50156 S-12-0590
Pressurizing tool IT LV "AZ" DN 50/65 top & bottom		Valves LV & DT DN 50/65 Inspection of metal bellows	0980.50100 S-12-0533
Pressurizing tool IT LV "AZ" DN 80/100 top & bottom			Valves LV & DT DN 80/100 Inspection of metal bellows
	Fig.12		

List of tools (in alphabetical order)			
Tool	Figure	Intended Purpose	Material Number GEA Aseptomag AG
Pressurizing tool IT LV "EA" DN 40 top & bottom	 <p>Fig.13</p>	Valves LV & DT DN 25/40 Inspection of metal bellows	0980.50358 S-12-0930
Pressurizing tool IT LV "EA" DN 50/65 top & bottom		Valves LV & DT DN 50/65 Inspection of metal bellows	0980.50359 S-12-0931
Pressurizing tool IT LV "EA" DN 80 top & bottom		Valves LV & DT DN 80 Inspection of metal bellows	-
Pressurizing tool IT LV "EA" DN 100 top & bottom		Valves LV & DT DN 100 Inspection of metal bellows	-
Torque wrench	 <p>Fig.14</p>	Mounting the valve seat seals (see supplementary instructions LV- DT_VSD Mounting the valve seat seal)	0980.50020 S-12-0086
Pressure control valve Ø 6 mm	 <p>Fig.15</p>	Inspection of metal bellows	9999.10090
Flexible head spanner Ø60-90mm, Pin Ø 5.5mm	 <p>Fig.16</p>	PA80-135 Remove/fit assembly spring	0980.10009 S-12-0332

List of tools (in alphabetical order)			
Tool	Figure	Intended Purpose	Material Number GEA Aseptomag AG
Flexible head spanner Ø95-155mm, Pin Ø 6mm	 Fig.17	PA180-PA210 Remove/fit assembly spring	0980.50131 S-12-0568
Hand-operated press	 Fig.18	Inner parts Removing / fitting the circlip in the stop sleeve	5050.55469 S-12-0406
the oven (no microwave, min. temp. 140 °C)	 Fig.19	Preheat hard valve seat seals	0981.50016 S-12-0084
Hex socket key AF5	 Fig.20	Valves DN 10 - DN 65 Tighten/release clamp LV DN25 - 40 EA Loosen / tighten internal assembly	0980.50121 S-12-0554
Hex socket key AF6		Valves DN 80 - DN 150 Tighten/release clamp	0980.50122 S-12-0555
Mounting tool LV/DT40		Inner parts DN 40 Removing / fitting the circlip / disk in the stop sleeve	0980.50168 / S-12-0602
Mounting tool LV/DT65		Inner parts DN 65 Removing / fitting the circlip / disk in the stop sleeve	0980.50167 / S-12-0581

List of tools (in alphabetical order)			
Tool	Figure	Intended Purpose	Material Number GEA Aseptomag AG
Mounting tool LV/DT100	Fig.21	Inner parts DN 100 Removing / fitting the circlip / disk in the stop sleeve	0980.50180 / S-12-0621
Mounting tool Clamping piece PA30-210	 Fig.22	PA30-210 Hold cylinder	5050.51064 S-12-0005
Mounting tool VSD NW65 DT/LV	 Fig.23	Removing and fitting the valve seat seals (see supplementary instructions LV- DT_VSD Mounting the valve seat seal)	0980.50021 S-12-0179
Mounting tool Spring package PA100-180 EA	 Fig.24	PA100-180 EA Remove/insert spring package	0981.50015 S12-0211
O-ring cutter heated IT LV "EA"	 Fig.25	Remove hard, shrunk- on valve seat seals	0980.50022 S-12-0083

List of tools (in alphabetical order)			
Tool	Figure	Intended Purpose	Material Number GEA Aseptomag AG
V-ring insertion tool	 Fig.26	Mounting the V-ring seal	229-109.88
Mounting tool O-ring	 Fig.27	Remove/fit seals	5050.51258 S-12-0162
Slotted screwdriver Size 4	 Fig.28	Inner parts Removing / fitting the circlip in the stop sleeve PA80-255 Fit assembly spring	--
Spanner adapter AF17	 Fig.29	Valves LV & DT DN50 - 80 EA Loosen / tighten internal assembly (see supplementary instructions LV- DT_VSD Mounting the valve seat seal)	5050.51605 S-12-0097
Vice with smooth jaws or equivalent type of protected jaws	 Fig.30	For divisible internal assemblies and actuators	--

List of tools (in alphabetical order)			
Tool	Figure	Intended Purpose	Material Number GEA Aseptomag AG
Protective gloves, heat-resistant	 Fig.31	Remove/fit hard valve seat seals	--
Seeger circlip pliers Inside diameter 40-100 mm, angled tip, 90°	 Fig.32	Inner part circlip on the bottom VA assemble/disassemble	0980.50108 S-12-0541
Shut-off valve Ø 6 mm	 Fig.33	Inspection of metal bellows	9999.10091
Socket wrench bit AF22, square drive ½"	 Fig.34	Supplementary instructions LV-DT_VSD Mounting the valve seat seal	0980.00011 S-12-0665

10.5 Prior to disassembly

Prerequisite:

- Make sure that while work is being performed on the open valve no process is in operation in the area concerned.

Carry out the following steps:

1. Drain all pipe system elements that lead to the valve and, if necessary, clean or rinse, and also depressurize them.
 2. Shut off the control air supply.
 3. Disconnect the power supply.
- Disassembly has been prepared.

10.6 Disassembling and Assembling the Valve

10.6.1 Removing the valve

Tools required:

- Hex socket key

Caution!

Danger of injury due to spring force being released

You can sustain injuries to your fingers when you put your hand into a valve if the valve has not been moved to the open position beforehand.

- ▶ Before starting any work, bring the valve to the "open" position.
- ▶ Wear protective gloves for all work.
- ▶ Always exercise caution and prudence.

Caution!

Danger of injury due to media escaping after removing the clamp

You can sustain injuries to your entire body if you open a valve that is still under pressure from the medium.

- ▶ Ensure that the valve is no longer under medium pressure before removing the clamp.
- ▶ Wear suitable protective clothing for all work.
- ▶ Always exercise caution and prudence.

Notice

Risk of damage to the metal bellows due to torsion or tension

The metal bellows can become damaged if the lower clamp is not loosened as described in the assembly instructions.

- ▶ Follow the instructions in this manual conscientiously.
- ▶ Always exercise caution and prudence.

Notice

Risk of the bottom bellows unit becoming loose due to torsion (EA system)

The valve can start to leak if the lower clamp is not loosened as described in the assembly instructions.

- ▶ Follow the instructions in this manual conscientiously.
- ▶ Always exercise caution and prudence.

Carry out the following steps:

1. Release the lower clamp with a suitable hex socket key, but do not unhook the screw yet.

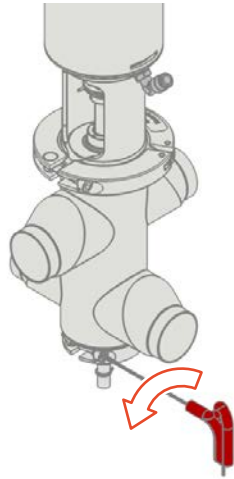

Fig.35: Loosening the lower clamp screw

! Ensure that you can move the clamp by hand and without much effort before carrying out the next step. If this is not the case, carefully hit the clamp segments with a plastic mallet until the pressure is released and the clamp can easily be moved afterwards.

2. Carefully take off the clamp from the valve. The inner part releases automatically as a result.
3. Bring the valve to the "open" position.

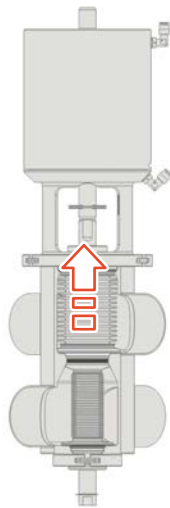

Fig.36: Apply valve NC

4. Release the upper clamp with a suitable hex socket key, but do not unhook the screw yet.

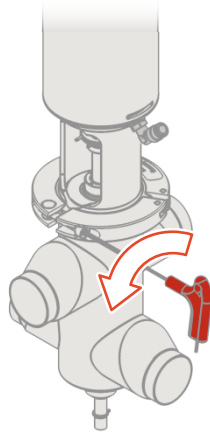

Fig.37: Loosening the upper clamp screw

! Ensure that you can move the clamp by hand and without much effort before carrying out the next step. If this is not the case, carefully hit the clamp segments with a plastic mallet until the pressure is released and the clamp can easily be moved afterwards.

5. Carefully take off the clamp from the valve.
6. Carefully lift the actuator with the internal assembly out of the housing.
! Do not damage the sealing surfaces on the valve housing.

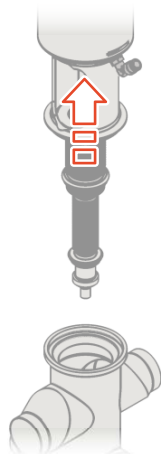

Fig.38: Removing actuator and internal assembly

→ Internal assembly and actuator are now separated from the housing.

10.6.2 Assembling the Valve

Carry out the following steps:

1. Install the valve in the reverse order of disassembly, see Section 10.6.1, Page 44.

! Note “Torques for clamp”, see Section 10.6.3, Page 47

2. Test the function of the valve after assembling.

! Every possible position must be activated and held for 3-5 seconds to assure proper assembly and sealing.

→ The valve has been assembled.

10.6.3 Torques for clamp

Clamp screw thread size	Recommended torque [Nm]
M6	10
M8	20

10.7 Disassembling and Assembling the Internal Assembly

10.7.1 Removing the internal assembly “AZ”

Caution!

Danger of injury due to valve parts moved by compressed air!

You can sustain injuries to your fingers when you put your hand into the valve while it is switching.

- ▶ Wear protective gloves for all work.
- ▶ Always exercise caution and prudence.

Requirement:

- Internal assembly and actuator have been separated from the housing, see Section 10.6.1, Page 44

Carry out the following steps:

1. Put the actuator in “closed” position (connection 1 ▲ D venting).



Fig.39: Bring the valve to the “closed” position

2. Pull the circlip out of the groove and remove the lock washer from the piston rod.

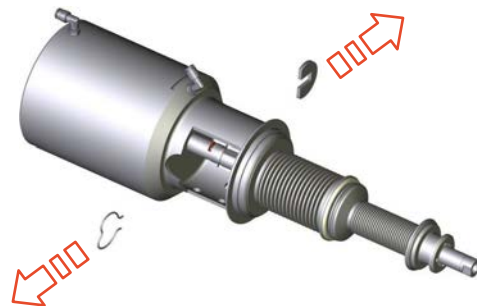

Fig.40: Removing fuse elements

3. Carefully remove the inner part out of the piston rod.

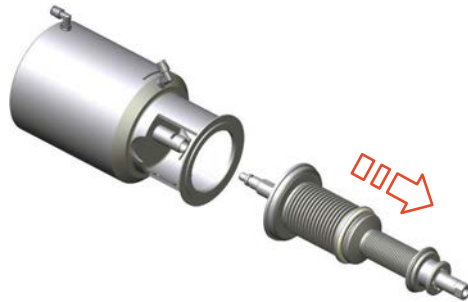

Fig.41: Removing the inner part

→ The internal assembly has been removed.

10.7.2 Installing the internal assembly “AZ”

Carry out the following steps:

1. Install the internal assembly in the reverse order of disassembly, see Section 10.7.1, Page 47.

→ The internal assembly has been assembled.

10.7.3 Disassemble internal assembly “EA”

Warning!

Danger of injury due to parts flying around!

Head and face injuries can occur if, during loosening and tightening of the thread, you apply pressure with compressed air to connection 1 ▲D on the actuator.

- ▶ Always hold the internal assembly directed away from your head and body.
- ▶ During loosening or tightening of the thread between the internal assembly and actuator, connection 1 ▲D must never have control air pressure applied.

Caution!

Danger of injury due to valve parts moved by compressed air!

You can sustain injuries to your fingers when you put your hand into the valve while it is switching.

- ▶ Wear protective gloves for all work.
- ▶ Always exercise caution and prudence.

Notice

Risk of damage to the metal bellow from torsion

The metal bellow can get damaged, if forces other than those described in these assembly instructions are used on the internal assembly.

- ▶ Follow the instructions in this manual conscientiously.
- ▶ Always exercise caution and prudence.

Requirement:

- Internal assembly and actuator have been separated from the housing, see Section 10.6.1, Page 44

Tools required:

- Vice with smooth jaws or equivalent type of protected jaws
- Jaw wrench for DN 50-100
- Hex socket key for DN 25-40

Carry out the following steps:

1. Put the actuator in “closed” position (connection 1 ▲ D venting).
Remove pneumatic hose from connection 1 ▲ D.
2. Clamp the pneumatic actuator at the width across flats of the piston rod into the vice.
! Do not damage piston rod!

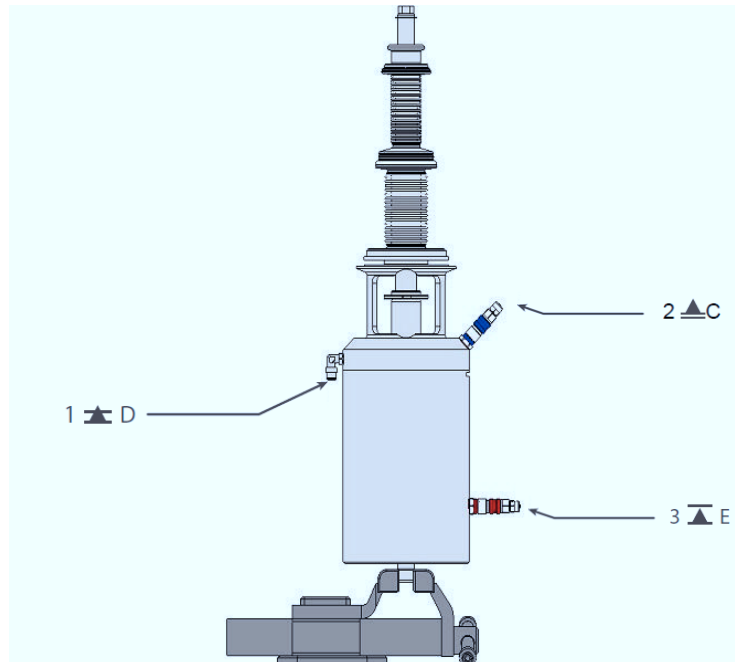

Fig.42: Clamping the actuator

3. Apply 6 bar of compressed air to connection 2 ▲ C of the actuator (vent valve seat B). Lift the circlip out of the groove and pull the lock washer out from the piston rod.

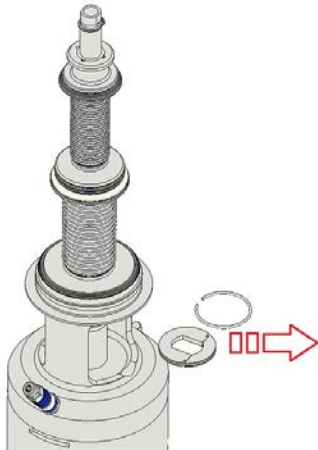

Fig.43: Removing fuse elements

4. Position the spanner adapter with ratchet and socket for wrench or with jaw wrench socket at the width across flats of the bottom bellows unit, loosen and carefully screw out from the piston rod of the pneumatic actuator.

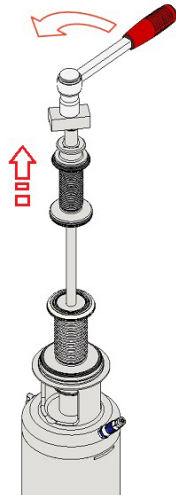

Fig.44: Loosening internal assembly

5. Pull the upper internal assembly out of the actuator.



Fig.45: Removing the upper internal assembly

6. Put the actuator in "closed" position (vent connection 2 \blacktriangle C).

→ The internal assembly "EA" has been removed.

10.7.4 Assemble internal assembly "EA"

Tools required:

- Vice with smooth jaws or equivalent type of protected jaws
- Hex socket key for DN 25-40
- Torque wrench with socket for wrench for DN 50-100
- Wrench adapter (50-100)

Carry out the following steps:

1. Install the internal assembly in the reverse order of disassembly, see Section 10.7.3, Page 48.

! Grease well the valve axle of the inside part at the thread and 5 mm of the adjoining axle to prevent possible corrosion.

! Insert the internal assembly by hand carefully and twisting slightly up to the metallic stop in the piston rod of the pneumatic actuator, and then tighten with torque wrench to 40 Nm (20 Nm for valve nominal size 25-40).

! Align leakage sockets (if present) by turning the top bellows unit towards the yoke opening. Align safety disk with circlip to the leakage socket of the internal assembly by turning the entire actuator. Turning the bottom bellows unit is strictly prohibited!

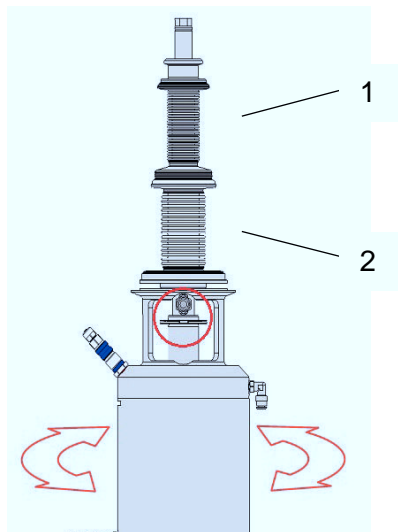

Fig.46: Aligning the yoke opening to the leakage socket and circlip

1	Bottom bellows unit
2	Top bellows unit

→ The internal assembly "EA" has been assembled.

10.8 Disassembling and Assembling the Seals on the Inner Part



Hint!

For an alternative disassembly / assembly of the valve seat seal (but not all seals of the inner part), see supplementary instructions LV-DT_VSD for UltraClean Leakage Valve Types LV and DT.

10.8.1 Disassemble the seals on the inner part "AZ"

For information on valve seat seals see Section 3.3, Page 20.

Requirement:

- The inner part has been separated from the actuator, see Section 10.7.1, Page 47.

Tools required:

- Hand-operated press
- Assembly tool LV/DT
- Slotted screwdriver
- Vice
- Open-ended wrench
- Seegering pliers
- Mounting tool for O-ring

Carry out the following steps:

1. Press the stop sleeve under the hand press downwards using the sleeve mounting tool until the circlip / disk is released.

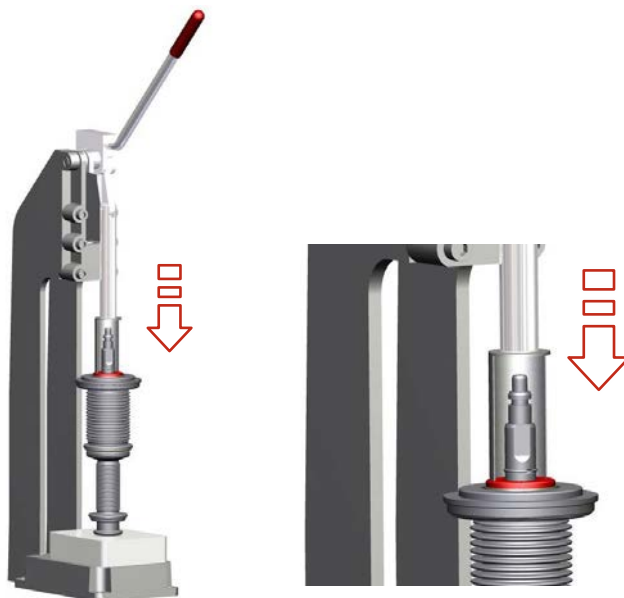

Fig.47: Stop sleeve loaded

2. Use a slotted screwdriver to lift the circlip / disk out of the groove and remove it.



Fig.48: Removing the circlip

3. Pressure slowly removed from the stop sleeve.

! When releasing, the stop sleeve is pressed upwards by the compression spring.

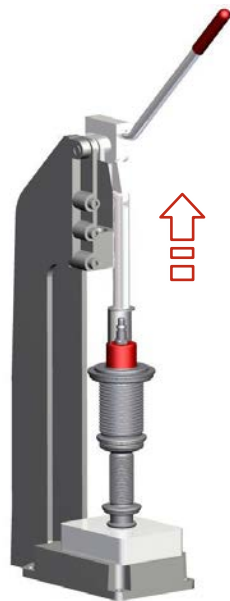

Fig.49: Stop sleeve relieved

4. Carefully remove the top inner part components from the axis.



Fig.50: Remove the top components

5. Remove the seals on the top bellows unit using the O-ring assembly tool.

! Do not damage the sealing grooves.



Fig.51: Removing the seals

6. Tighten the internal part on the key areas in the vice. Loosen the top axis from the bottom axis using an open-ended spanner and remove.

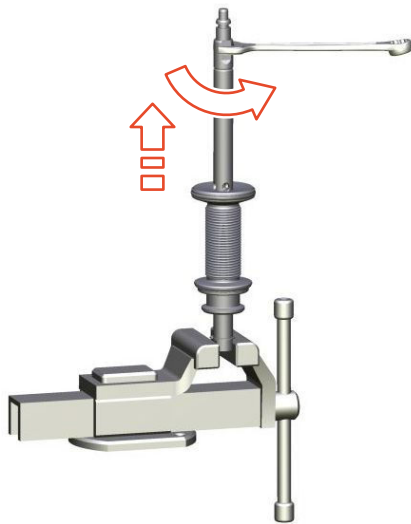

Fig.52: Remove upper axis

7. Remove the circlip on the bottom valve axis using the Seegerring pliers and remove the seals with the O-ring assembly tool
! Do not damage the sealing grooves.



Fig.53: Removing the seals

8. Thoroughly clean all sealing grooves and check for damage.

→ The inner part components are disassembled.

10.8.2 Disassembling the seals on the inner part AZ



Hint!

Seals in the product-contacting area are not lubricated. To facilitate assembly (better gliding properties and securing against turning), this type of elastomer seal may, however, be wetted using a food-grade lubricant.

Wetting elastomer seals is not permitted when they are used in ATEX applications!

Tools required:

- Hand-operated press
- Assembly tool LV/DT
- Vice
- Open-ended wrench
- Seegering pliers
- Mounting tool for O-ring
- Food-grade lubricant PARALIQ GTE 703
- Oven (no microwave)
- Heat-resistant gloves

Carry out the following steps:

1. Mount the seals on the bottom valve axis with the O-ring assembly tool and fit the circlip using the Seegerring pliers.

Maintenance

Disassembling and Assembling the Seals on the Inner Part



Fig.54: Mount the seals

2. Tighten the internal part on the key areas in the vice. Fit the top axis to the bottom axis and tighten with an open-ended spanner.

Note table “Torques for divisible valve discs”, see Section 10.8.3, Page 58

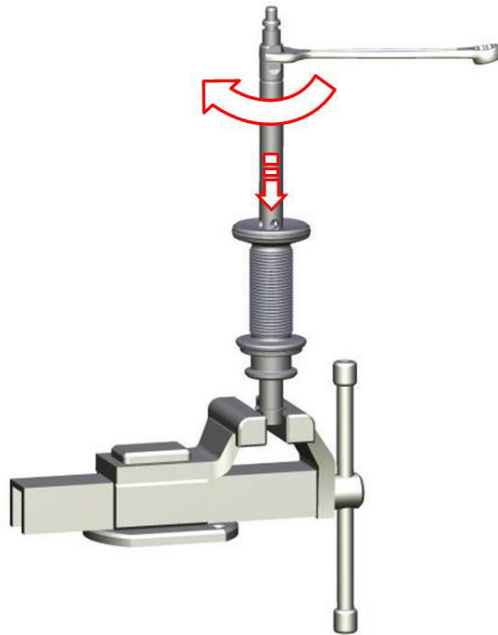

Fig.55: Fit upper axis

3. Mount the elastomer seals on the top bellows unit using the O-ring assembly tool.



Fig.56: Mount the seals

4. Heat new thermoplastic valve seat seal for seat B in the oven.

- Temperature: 140 °C (guideline value)
- Time: 3 - 5 minutes (guideline value)

! Ensure that the seal can be deformed along the circumference without much effort. The heating time required depends on the type of oven and can vary accordingly.



Fig.57: the oven

5. Insert heated seat seal into the groove of the internal assembly.

! Valve seat seals made of hard sealing materials must not be greased.

! The heated valve seat seal must fit tightly into the groove.

! After inserting the seal, immediately carry out the next work step.

-> The valve seat seal is still too rigid and cannot be inserted accurately into the groove?

- Reheat the valve seat seal as described in the previous instruction step.

6. Carefully pull the inner part components with mounted elastomer seals onto the valve axis, slowly press the stop sleeve under the hand press downwards using the sleeve assembly tool until the groove is visible and press the circlip / disk into the groove.

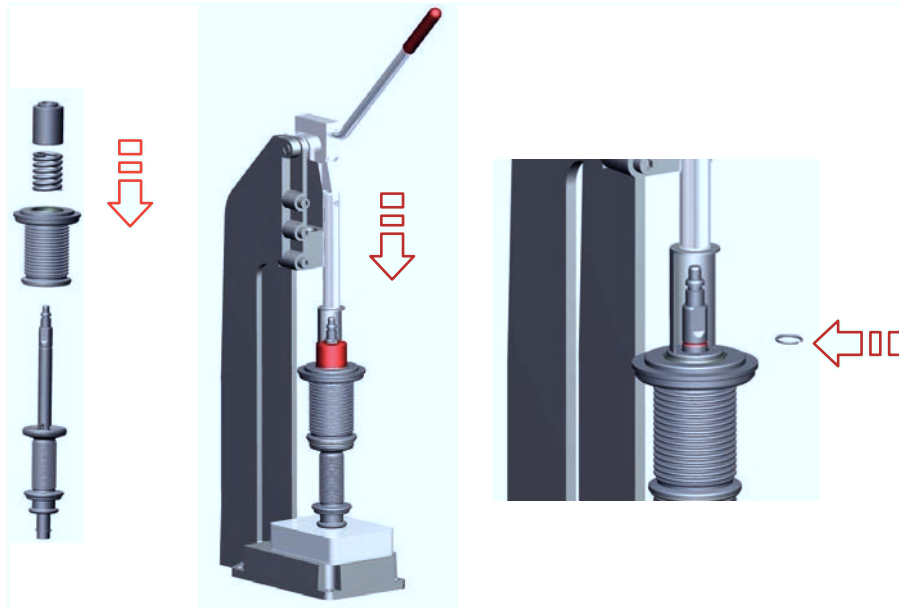

Fig.58: Pulling on and securing the inner part components

→ The inner part components are assembled.

10.8.3 Torques for divisible valve discs

Valve size	Thread size of valve disc	Torque [Nm]
DN25	M10 x 1.25	50
DN40	M10 x 1.25	50
DN50	M16 x 1.5	50
DN65	M16 x 1.5	50
DN80	M16 x 1.5	50
DN100	M16 x 1.5	50

10.8.4 Removing the EA "shrink-on system" valve seat seal

For information on valve seat seals, see Section 3.3, Page 20

Tools required:

- O-ring cutter
- Heat-resistant protective gloves

⚠ Caution!

Health hazard due to toxic fumes!

The *O-ring cutter* cuts the seal with a hot metal tip. At temperatures of more than 300 °C, toxic fumes can be released.

- ▶ Avoid directly inhaling the fumes.

⚠ Caution!

Risk of injury due to hot and sharp-edged parts!

The *O-ring cutter* cuts the seal with a hot metal tip. This process heats up the seal and possibly also metal parts of the valve.

► When removing the valve seat, always wear *heat-resistant protective gloves*.

Carry out the following steps:

1. Place the heated metal tip of the *O-ring cutter* at right angles on the valve seat to be removed.
2. Cut through the valve seat seal at one point using the *O-ring cutter*.

! Pay attention not to damage the edge of the radial groove.

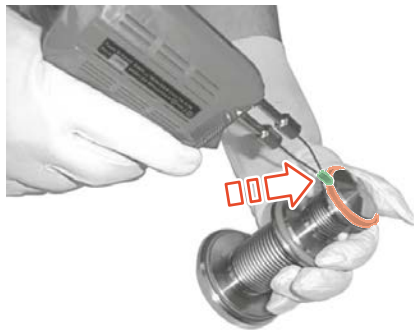

Fig.59: Cut through valve seat seal

3. Take out the cut valve seat seal.
→ The valve seat seal has been removed.
4. Remove the seals on the top bellows unit using the O-ring assembly tool.

! Do not damage the sealing grooves.

For instructions on removing the V-ring seal, see Section 10.8.6, Page 62.

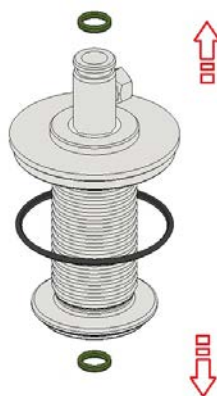

Fig.60: Top bellows unit, removing the seals

5. Remove the seals on the bottom bellows unit using the O-ring assembly tool.

! Do not damage the sealing grooves.

! For instructions on removing the V-ring seal, see section Section 10.8.6, Page 62.



Fig.61: Bottom bellows unit, removing the seals

→ Seals are removed.

10.8.5 Fitting the EA "shrink-on system" valve seat seal



Hint!

Statically loaded seals in the product-contacting area are generally not lubricated. To facilitate assembly (better gliding properties and securing against turning), this type of elastomer seal may, however, be wetted using a food-grade lubricant.

! Wetting elastomer seals is not permitted when they are used in ATEX applications!



Hint!

Pay attention to the following points when assembling the valve seat seal:

- Thoroughly clean all parts and check for damage.
- Replace all dismantled seals.
- When changing the seals, do not damage the seal groove.
- Use only replacement seals from the sealing set indicated in the list of spare parts.

! Valve seat seals made of hard sealing materials must not be greased!

Tools required:

- Oven (no microwave)
- Heat-resistant protective gloves
- New valve seat seal

Carry out the following steps:

1. Heat the new valve seat seal in the *oven*.

- Temperature: 140 °C (guideline value)
- Time: 3 - 5 minutes (guideline value)

! Ensure that the seal can be deformed along the circumference without much effort. The heating time required depends on the type of *oven* and can vary accordingly.



Fig.62: the oven

2. Use both thumbs to press the heated valve seat seal into the radial groove at one point.



Fig.63: Place the valve seat seal into the groove

3. Then use both thumbs/palms to press the valve seat seal in place in the radial groove.

! Make sure the valve seat seal "clicks" into the radial groove. The audible clicking noise indicates that the seal has been fitted correctly.

! The valve may not be totally leak-proof after a new TEFASEP® valve seat seal has been fitted. The valve seat seal will adjust itself optimally to the sealing surfaces only after the first sterilisation of the valve (see Chapter 9, Page 33). Afterwards it will ensure perfect sealing up to the maximum closing pressure or vacuum.



Fig.64: Mounting the valve seat seal

- The valve seat seal is still too rigid and cannot be mounted?
 - Reheat the valve seat seal as described in the previous instruction step.
- When installing the valve seat seal, the seal does not "click" into place any more?
 - The valve seat seal has been overheated and can no longer be used.
 - Repeat the operation with a new valve seat seal.
 - Observe the data specified for heating the valve seat seal.
- The valve seat seal has been fitted.

10.8.6 Replacing V-ring top bellows unit "EA"



Hint!

Replace defective seals, but always fit new housing O-rings to ensure the tightness of the valve. Always use genuine spare parts.

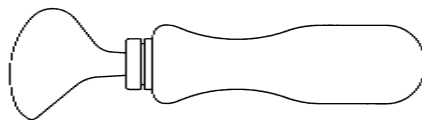

Fig.65: V-ring insertion tool

Requirement:

- Insert V-Ring without grease. To facilitate fitting, use water with a drop of washing-up liquid to remove the surface tension. In order that no rust is transferred, the washing-up liquid solution must be made up in a ceramic, plastic, or stainless steel container.

Tools required:

- V-ring insertion tool

⚠ Caution!

Danger of injury!

The pickset tool can slip off when the V-ring is removed

- ▶ Clamp the valve disk in the vice using vice supports

ℹ Hint!

Functional and running surfaces of the valve disks must not get damaged.

Carry out the following steps:

1. Put a tool from the pickset into the V-ring and take it out.

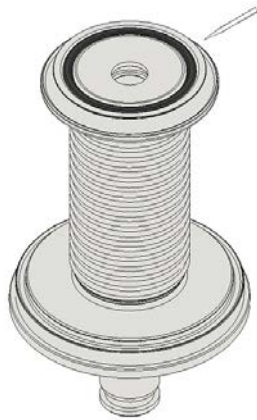

Fig.66: Replacing the V-ring AX

2. Before fitting, wet the V-ring on the side not in contact with product (rear side). Pay attention that water does not drip into the V-ring groove on the valve disc.
3. Put in the V-ring. Make sure the installation position of the V-ring is correct.

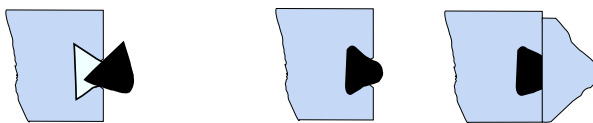

Fig.67: Axial V-ring (chamber seal)

4. Use the insertion tool to press in the V-ring – evenly press in at several opposite points along the circumference.

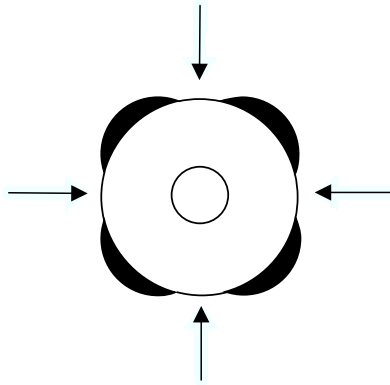

Fig.68

5. Insert the V-ring evenly.

! Check that the V-ring is evenly and correctly inserted.

→ Done



Hint!

Used seals must not be used again, since the proper function of the seal can then no longer be ensured.

10.8.7 Replacing V-ring bottom bellows unit "EA"



Hint!

Replace defective seals, but always fit new housing O-rings to ensure the tightness of the valve. Always use genuine spare parts.



Caution!

Danger of injury!

The pickset tool can slip off when the V-ring is removed

► Grip the valve disk in a vice with protected jaws.

Carry out the following steps:

1. Puncture the V-ring using the pickset tool and take it out.

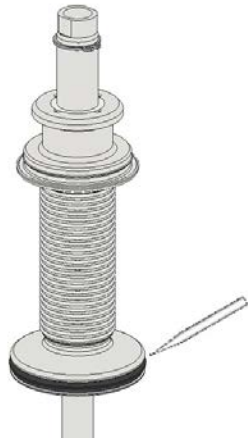

Fig.69: Replacing the V-ring

2. Before fitting, wet the V-ring on the side not in contact with product (rear side).
! Pay attention that water does not drip into the V-ring groove on the valve disc.
3. Put in V-ring RA.
! Make sure the installation position of the V-ring is correct.

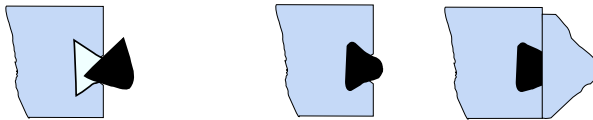

Fig.70: Radial V-ring (bottom bellows unit)

4. Use the insertion tool to press in the V-ring – evenly press in at several opposite points along the circumference.

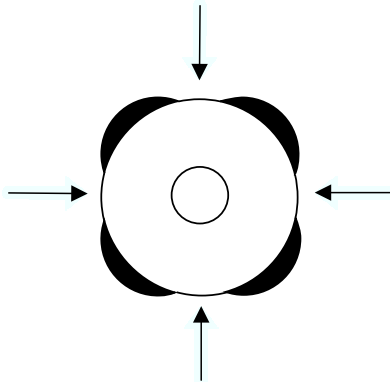

Fig.71

5. Insert the V-ring evenly.
! Check that the V-ring is evenly and correctly inserted.
 6. Replace all the other seals identified in the spare parts lists.
- Done



Hint!

Used seals must not be used again, since the proper function of the seal can then no longer be ensured.

10.9 Carrying out the “Internal Assembly” Leak Test (Bubble Test)

10.9.1 Bubble test of the top bellows unit



Hint!

Observe the inspection interval! The metal bellows must be checked for leaks as part of the annual maintenance using the pressurizing tool.

Notice

Risk of damage to the metal bellow from torsion

The metal bellow can get damaged, if forces other than those described in these assembly instructions are used on the internal assembly.

- ▶ Follow the instructions in this manual conscientiously.
 - ▶ Always exercise caution and prudence.
-

Requirement:

- Top bellows unit is disassembled, see Section 10.8.1, Page 52.

Tools required:

- Pressurizing tool IT LV top
- Compressed air supply
- Shut-off valve Ø 6 mm
- Pressure control valve Ø 6 mm
- Water bath

Carry out the following steps:

1. Insert the pressurizing shaft through the valve disc into the bellows unit from underneath.

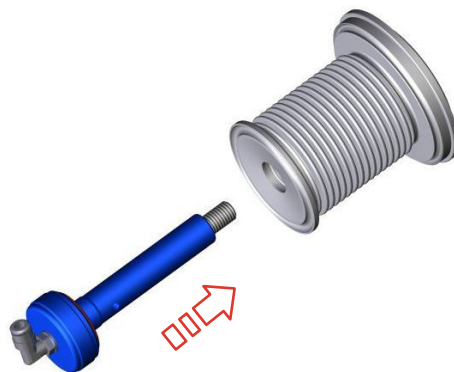

Fig.72: Insert the pressurizing shaft

2. Bolt the pressurizing housing with the pressurizing shaft. Tighten the pressurizing unit to the stop.

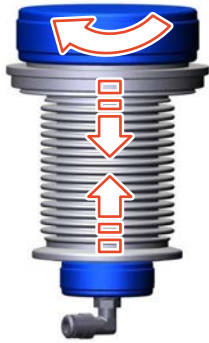

Fig.73: Screw the pressurizing housing tight

3. Apply max. 3 bar of compressed air to the pressurizing tool.
! Air pressures > 3 bar can damage the metal bellows.
4. Immerse the bellows unit in a water bath for approx. 30 seconds.
! While immersed, check the bellows unit for leaks. Leakages will be indicated by air bubbles appearing on the surface.

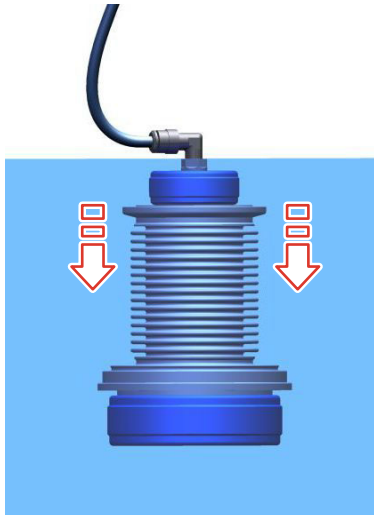

Fig.74: Water bath

5. Remove the bellows unit from the pressurizing tool in reverse order.
→ This completes the leak test.

10.9.2 Bubble test of the bottom bellows unit

Notice

Risk of damage to the metal bellow from torsion

The metal bellow can get damaged, if forces other than those described in these assembly instructions are used on the internal assembly.

- ▶ Follow the instructions in this manual conscientiously.
- ▶ Always exercise caution and prudence.



Hint!

Observe the inspection interval! The metal bellows must be checked for leaks as part of the annual maintenance using the pressurizing tool.

Requirement:

- Bottom bellows unit is disassembled, see Section 10.8.1, Page 52.

Tools required:

- Pressurizing tool IT LV bottom
- Compressed air supply
- Shut-off valve Ø 6 mm
- Pressure control valve Ø 6 mm
- Water bath

Carry out the following steps:

1. Insert the bellows unit in the pressurizing housing.

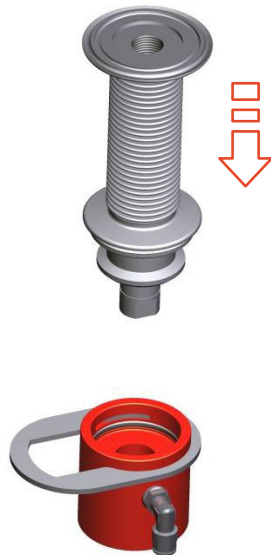

Fig.75: Inserting the bellows unit

2. Close the slider. This fixes the pressurizing housing to the bellows unit.



Fig.76: Fixing the pressurizing housing

3. Insert the threaded rod with star handle into the bellows unit from the top.

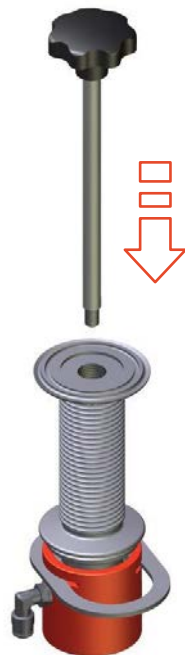

Fig.77: Inserting the threaded rod

4. Screw the threaded rod with pressurizing housing to the stop.



Hint!

Threaded rod is not required with the EA system.

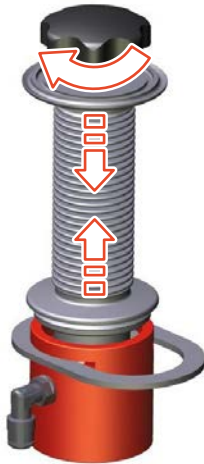

Fig.78: Bolting the mounting tool

5. Apply max. 3 bar of compressed air to the pressurizing tool.
! Air pressures > 3 bar can damage the metal bellows.
6. Immerse the bellows unit in a water bath for approx. 30 seconds.
! While immersed, check the bellows unit for leaks. Leakages will be indicated by air bubbles appearing on the surface.

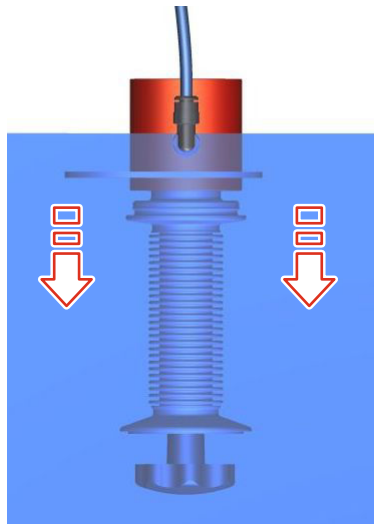

Fig.79: Water bath

7. Remove the bellows unit from the pressurizing tool in reverse order.
→ This completes the leak test.

10.10 Disassembling and Assembling the Actuator

10.10.1 Disassembling Actuator PA80DT - PA180DT



Hint!

The pneumatic actuator PA DT is used in the UltraClean leakage bottom seat valve DT as well as in the UltraClean leakage valve LV. The disassembly and assembly of the actuator version PA DT RS (backflow block) is identical to the version PA DT.

Tools required:

- Flexible head spanner
- Slotted screwdriver
- Assembly tool for clamping device
- Assembly tool for O-ring
- Vice

Preparing disassembly

Carry out the following steps:

1. Bring the actuator to the non-actuated position.
2. Remove the feedback unit.
3. Fasten assembly tool "clamping piece" on the rear of the actuator.



Fig.80: Attaching clamping piece

4. Grip the actuator in the vice using the clamping piece.

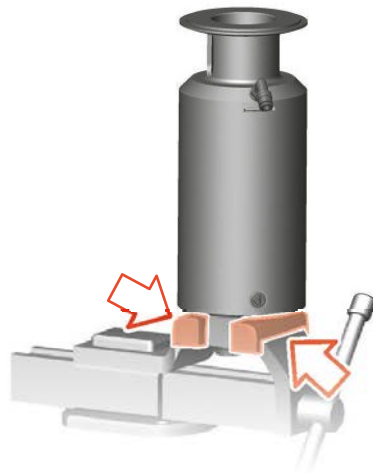

Fig.81: Clamping the actuator

→ Disassembly has been prepared

Removing assembly spring

Carry out the following steps:

1. Turn the actuator base counter-clockwise using a flexible head spanner, see illustration.
! Rotate the actuator base until the assembly spring begins to move out of the slot in the cylinder.

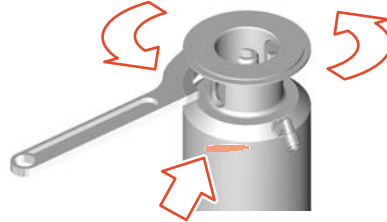

Fig.82: Releasing assembly spring

2. Turn the actuator base clockwise using the flexible head spanner.
! Rotate the actuator base until the assembly spring can be removed.

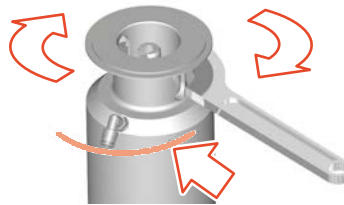

Fig.83: Unscrewing assembly spring

→ Assembly spring has been removed.

PA80DT - PA180DT: dismantling the actuator

Carry out the following steps:

1. Lift off the actuator base from the cylinder.



Fig.84: Removing actuator base

2. Pull the laminated spring out of the cylinder.



Fig.85: Lifting out spring assembly

- Actuator has been dismantled into its individual parts.
- ! Opening the spring assembly is not recommended for safety reasons.

→ Actuator PA80DT - PA180DT has been disassembled.

10.10.2 Assembling Actuator PA80DT - PA180DT



Hint!

Pay attention to the following points when assembling the actuator:

- Replace all visible seals.
- Thoroughly clean and check the interior cylinder contact surfaces, O-ring grooves, piston rod and piston disc.
- When changing the seals, do not damage the seal groove.
- Use only replacement seals from the seal set indicated in the list of spare parts.
- Grease all seals and the associated contact surfaces with the food-grade lubricant PARALIQ GTE 703.

PA80DT - PA180DT: assembling the actuator

Carry out the following steps:

1. Assemble the actuator in the reverse order of disassembly, see Section 10.10.1, Page 70.

→ Actuator has been assembled.

Installing the assembly spring

Tools required:

- Flexible head spanner
- Slotted screwdriver

Carry out the following steps:

1. Align the actuator base relative to the cylinder housing so that the hole in the base is visible through the slot in the cylinder.

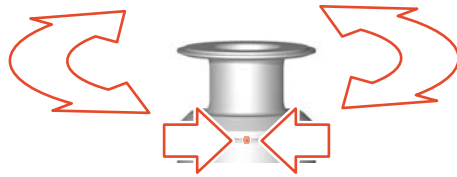

Fig.86: Aligning hole to slot

2. Insert the angled part of the assembly spring into the hole of the actuator base.

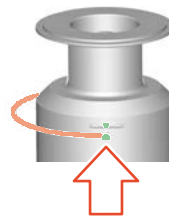

Fig.87: Hooking in the assembly spring

3. Turn the actuator base 360° counter-clockwise using a flexible head spanner.
→ The assembly spring is pulled into the cylinder.

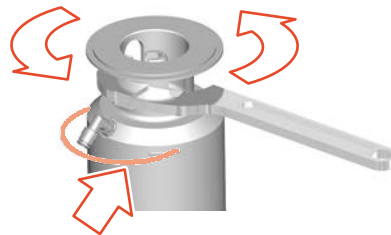

Fig.88: Screwing in the assembly spring

4. As soon as both open ends of the assembly spring are visible in the slot area, the beginning of the assembly spring must be pressed into the hole in the actuator base with a slotted screwdriver.

! Carefully continue to turn the actuator base at the same time.

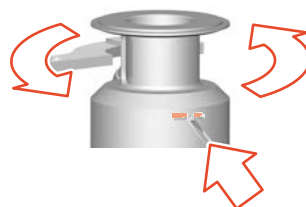

Fig.89: Fastening the assembly spring

- The assembly spring moves out of the hole when it reaches the slot in the cylinder and actuator base was turned further?

- Continue to turn the actuator base counter-clockwise using the flexible head spanner until the hole is again located underneath the position pin of the assembly spring and the pin can be pressed in again with the slotted screwdriver.
5. Position the compressed air connection centrally over the slot in the cylinder.

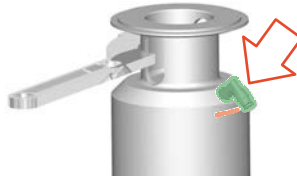

Fig.90: Placing the air connection

- Assembly spring has been fitted.
- Actuator PA80DT - PA180DT has been assembled.

10.10.3 Disassembling the LV/DT actuator PA80EA - PA255EA

Tools required:

- Flexible head spanner
- Slotted screwdriver
- Mounting tool clamping piece
- Mounting tool for spring package
- Mounting tool for O-ring
- Vice

Preparing removal

Carry out the following steps:

1. Prepare disassembly, see Page 71.
- Disassembly has been prepared

Removing assembly spring

Carry out the following steps:

1. Disassemble assembly spring, see Page 71.
- Assembly spring has been removed.

Dismantling the PA80EA - PA255EA actuator

Carry out the following steps:

1. Lift off the actuator base from the cylinder.

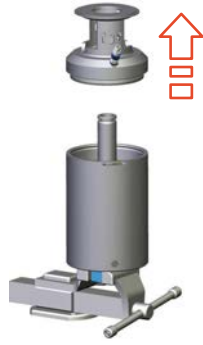

Fig.91: Removing actuator base

2. Pull the spring assembly upwards at the piston rod out of the cylinder.



Fig.92: Lifting out top spring assembly

3. Use the *assembly tool for the spring package* to pull the bottom spring assembly upwards out of the cylinder.



Fig.93: Lifting out bottom spring assembly

4. Lift the circlip out of the groove with a *slotted screwdriver* and remove it.

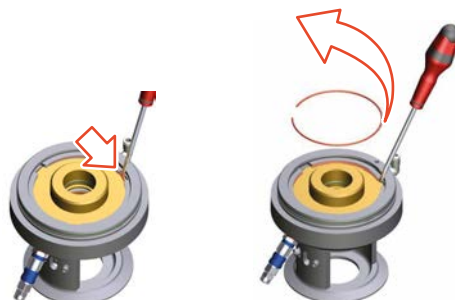

Fig.94: Removing circlip

5. Take the buffer segments out of the actuator base.



Fig.95: Removing fuse elements

6. Lift the piston disc out of the actuator base.



Fig.96: Lifting out the piston disc

→ Actuator has been dismantled into its individual parts.

! Opening the spring assembly is prohibited for safety reasons.

→ Actuator PA80EA - PA255EA has been removed.

10.10.4 Fitting the LV/DT actuator PA80EA - PA255EA



Hint!

Pay attention to the following points when installing the actuator:

- Replace all visible seals.
- Thoroughly clean and check the interior cylinder contact surfaces, O-ring grooves, piston rod and piston disc.
- When changing the seals, do not damage the seal groove.
- Use only replacement seals from the sealing set indicated in the list of spare parts.
- Grease all seals and the associated contact surfaces with the food-grade lubricant PARALIQ GTE 703.

Assembling the PA80EA - PA255EA actuator

Carry out the following steps:

1. Assemble the actuator in the reverse order of disassembly, see Section 10.10.3, Page 75.

2. For details on how to connect actuator base and cylinder, see fitting the assembly spring, Page 75.

→ The LV/DT actuator PA80EA- PA255EA is fitted.

10.11 Maintenance

Well-planned maintenance is essential to ensure a long service life of the valve. Observe the following maintenance intervals. Prepare maintenance activities well:

- Keep a maintenance log for the valve.
- Use the statistical analyses for your plant to plan maintenance intervals.

Only allow qualified maintenance staff to carry out maintenance work.



Hint!

Prior to any work on the open valve, ensure that it has stopped operation, see Section 10.5, Page 43.

The following information and values are based on the experience of GEA Aseptomag AG and apply for installations working in 2-shift operation.

Activities to be performed once a month	
Component	Activity to be performed
Valve	Visual inspection

Activities to be performed after 3 months (only after initial commissioning or after a process change)	
Component	Activity to be performed
Product contact seals	Check of mechanical parts and visual inspection of condition
Internal assembly with bellows	Check of mechanical parts and visual inspection of condition Leak test of bellows (bubble test)
Actuator	Function check
Valve	Function check
Feedback	Function check
Pneumatic connections	Check of mechanical parts and visual inspection of condition Leak test
Electrical connections	Visual inspection

Activities to be performed once a year	
Component	Activity to be performed
Product contact seals	Seal replacement
Internal assembly with bellows	Check of mechanical parts and visual inspection of condition Leak test of bellows (bubble test)
Actuator	Check of mechanical parts and visual inspection of condition Function check
Valve	Check of mechanical parts and visual inspection of condition Function check
Feedback	Check of mechanical parts and visual inspection of condition Function check
Pneumatic connections	Check of mechanical parts and visual inspection of condition Leak test
Electrical connections	Check of mechanical parts and visual inspection of condition
Activities to be performed every 5 years	
Component	Activity to be performed
Actuator	Maintenance including seal replacement

10.12 Checking the Feedback Unit

After completing maintenance work, check the function of the feedback unit and readjust it if necessary.

10.12.1 Setting the Feedback Unit

Carry out the following steps:

1. Set the initiator for detection of the rest position.
2. Actuate the valve with compressed air.

→ For information on air connections see Section 6.4, Page 26.

If provided, adjust the initiator for the actuated position. For reference regarding the stroke to be expected see the "Valve Stroke" table Section 10.12.2, Page 80.

→ The feedback unit has been set.

**Hint!**

If a control head is present, the information given in the corresponding instruction manual must be observed.

10.12.2 Valve stroke

Strokes depending on the size (theoretical values based on drawing) (AZ)		
Size	Valve stroke [mm]	
	Total stroke	Venting seat A
DN40 / 1½"OD	16.7	7
DN50 / 2"OD	23	5.5
DN65 / 2½"OD	23	5.5
DN80 / 3"OD	24.5	5.7
DN100 / 4"OD	24.5	9

Strokes depending on the size (theoretical values based on drawing) (EA)			
Size	Valve stroke [mm]		
	Total stroke	Venting seat A	Venting seat B
DN25 / 1"OD	20.3	6	1.5
DN40 / 1½"OD	20.3	6	1.5
DN50 / 2"OD	23	3.4	1.5
DN65 / 2½"OD	23	3.4	1.5
DN80 / 3"OD	-	-	-
DN100 / 4"OD	-	-	-

11 Alarms

11.1 Malfunctions and remedies

Notice

Warning of damage to property/loss of product

Ignoring malfunctions may cause considerable damage to property and loss of product. The safe operation of the valve in the event of a malfunction can no longer be taken for granted and in the worst case can result in a loss of sterility in the process.

- ▶ Make sure that malfunctions are quickly identified and promptly fixed.

In the event of malfunctions immediately deactivate the valve and secure it against inadvertent reactivation. Malfunctions may only be remedied by qualified staff, who must observe the safety precautions. For malfunctions not listed in the table below, contact the manufacturer.

Malfunction	Cause	Remedy
Medium is leaking from the clamp.	The housing seal is not fitted correctly or damaged.	Fit the housing seal correctly or replace it if damaged.
Medium is leaking from the leakage holes of the internal assembly.	The metal bellows on the internal assembly is defective.	<ul style="list-style-type: none"> • Replace the complete internal assembly. • Send the defective internal assembly to the manufacturer for repair.
Media escapes at the leakage opening.	<ul style="list-style-type: none"> • The valve seat seal is defective. • Unintentional switching of the seat venting of seat A or B. 	<ul style="list-style-type: none"> • Replace the valve seat seal(s). • Checking the control / programming.
During pressure testing of the internal assembly, air escapes from the metal bellows.	The metal bellows on the internal assembly is defective.	<ul style="list-style-type: none"> • Replace the complete internal assembly. • Send the defective internal assembly to the manufacturer for repair.
Leak at the valve seat.	<ul style="list-style-type: none"> • The valve seat seal is defective. • Product deposits on the valve seat. 	<ul style="list-style-type: none"> • Replace the valve seat seal. • Check the housing.
The maximum valve stroke is not reached when the valve is actuated pneumatically.	Leakage in the actuator.	<ul style="list-style-type: none"> • Check the sealing surfaces in the actuator for damage. • Replace the seals.

Malfunction	Cause	Remedy
Valve feedback not correct.	<ul style="list-style-type: none"> • The feedback unit is not fitted correctly. • The proximity switch is not in the correct position or is defective. • Fault in the power supply. 	<ul style="list-style-type: none"> • Check that the feedback unit has been fitted correctly. • Check the position of the proximity switch and re-adjust if necessary. • Check the wiring.
Actuator is filling with water.	<ul style="list-style-type: none"> • Unfavourable fitting position of the vent screw on the actuator. • Unfavourable effect of the exterior cleaning of the plant. 	<ul style="list-style-type: none"> • If possible, position the vent screw so that it faces downwards. • When the valve is installed in the vertical position, ensure that the vent screw faces away from the cleaning direction if possible.
The TEFASEP valve seat seal is not tight after commissioning or maintenance.	<ul style="list-style-type: none"> • The valve seat seal has not been fitted correctly. • With new seal: The valve has not been actuated during/immediately after sterilization. 	<ul style="list-style-type: none"> • Fit the valve seat seal properly. • Actuate the valve during/ immediately after sterilisation.

12 Decommissioning

12.1 Safety instructions

For shutting down, the following principles apply:

- Switch off the compressed air.
- Switch off the component with the main switch.
- Padlock the main switch (if fitted) in the off position to prevent it from being switched back on. The key to the padlock must be deposited with the person responsible until the machine is restarted.
- For longer periods of standstill, observe the storage conditions, see Chapter 4, Page 22.

12.2 Disposal

12.2.1 General notes

Dispose of the component in an environmentally safe manner. Observe the statutory waste disposal regulations applicable at the place of installation.

The component consists of the following materials:

- Metals
- Synthetic materials
- Electronic parts
- Lubricants containing oil and grease

Separate the different materials and dispose of them correctly sorted. Also observe the instructions regarding disposal in the operating instructions for the individual components.

13 Appendix

13.1 Lists

13.1.1 Abbreviations and terms

Abbreviation	Explanation
°	Symbol for the grade of a scale [degrees] All degree data is assumed to be angle degrees unless explicitly specified otherwise.
°C	Unit of measurement of temperature [degree Celsius]
°F	Unit of measurement of temperature [degree Fahrenheit]
AISI	American Iron and Steel Institute; material designation
ATEX	Atmosphères Explosibles Directive of the European Union on explosion protections
AZ	Venting cylinder
bar	Unit of measurement of pressure [bar] All pressure data is assumed to be gauge pressure [barg] unless explicitly specified otherwise.
CFR	Code of Federal Regulations; collection of US federal regulations
d	Short name for diameter
DIN	German standard issued by DIN (Deutsches Institut für Normung e.V., German Institute for Standardisation)
dm ³ _N	Unit of measurement of volume [cubic decimetre under standard conditions]
DN	DIN nominal width
EA	Single venting
EN	European Standard
EPDM	Ethylene Propylene Diene Rubber Material designation, short designation according to DIN/ISO 1629
FDA	U.S. Food and Drug Administration Food monitoring and drug administration in the USA
FEP	Fluorinated ethylene propylene; material designation, short name
H ₂ O ₂	Hydrogen peroxide; chemical formula
ISO	International Standard of the International Organization for Standardization
ACSC	Air-closing/spring-opening; direction of action air
m/s	Unit of measurement of speed/velocity [metres per second]
min.	Unit of measurement of time [minute]
mm	Unit of measurement of length [millimetre]

Abbreviation	Explanation
µm	Unit of measurement of length [micrometre]
NC	Normally Closed; direction of action spring-closing/air-opening
Nm	Unit of measurement of work [newton metre] Specification for the torque: 1 Nm = 0.737 lbft Pound-Force (lb) + Feet (ft)
NO	Normally Open; direction of action air-closing/spring-opening
OD	Outside diameter; short name for outside diameter for inch tubes according to DIN 11866-C
PA	Pneumatic actuator
PTFE	Polytetrafluoroethylene Material designation, short designation according to DIN/ISO 1629
SW	Width across flats; indicates the size of spanners
TEFASEP®	Sealing material for the valve seat seal
T.VIS	Tuchenhagen valve information system
TV	Divisible valve disk; to valve seat seal system "divisible"
VR	V-ring
TIG	Tungsten inert gas welding



We live our values.

Excellence · Passion · Integrity · Responsibility · GEA-versity

GEA Group is a global engineering company with multi-billion euro sales and operations in more than 50 countries. Founded in 1881, the company is one of the largest providers of innovative equipment and process technology. GEA Group is listed in the STOXX® Europe 600 Index.

GEA Switzerland

GEA Aseptomag AG
Industrie Neuhof 28
CH-3422 Kirchberg

Tel +41 (0)34 426 29 29
Fax +41 (0)34 426 29 28

service.aseptomag@gea.com
gea.com