



## Aseptic Valves

GEA Aseptomag<sup>®</sup> shut-off bottom seat valve type AVBS

Operating instruction (Translation from the original language)

430BAL012533EN\_1

---

## **COPYRIGHT**

These Operating Instructions are the English translation of the original operating instructions in the sense of the EU Machinery Directive. This document is protected by copyright. All rights reserved. The document may not, in whole or in part, be copied, reproduced, translated or reduced to an electronic medium of machine-readable form without the express permission of GEA Tuchenhausen GmbH.

## **LEGAL NOTICE**

### **Word marks**

Aseptomag® and TEFASEP® are registered trademarks of GEA Aseptomag AG and may not be used without the permission of GEA Aseptomag AG.

T.VIS® is a protected trademark of GEA Tuchenhausen GmbH.

---

## TABLE OF CONTENTS

<b>1</b>	<b>General Information</b>	<b>5</b>
1.1	Information on the Document	5
1.1.1	Binding Character of These Operating Instructions	5
1.1.2	Notes on the Illustrations	5
1.1.3	Symbols and Highlighting	5
1.2	Manufacturer address	6
1.3	Customer service	6
1.4	EC Declaration of Incorporation	7
<b>2</b>	<b>Safety</b>	<b>8</b>
2.1	Intended use	8
2.1.1	Requirements for operation	8
2.1.2	Pressure equipment directive	8
2.1.3	ATEX directive	8
2.1.4	Improper operating conditions	8
2.2	Operator's Duty of Care	9
2.3	Subsequent changes	10
2.4	General safety instructions and dangers	10
2.4.1	Principles for safe operation	10
2.4.2	Environmental Protection	10
2.4.3	Electrical Equipment	11
2.5	Supplementary Regulations	11
2.6	Qualification of Staff	11
2.7	Safety equipment	12
2.7.1	Signage	12
2.8	Residual dangers	13
2.9	Danger zones	13
<b>3</b>	<b>Description</b>	<b>15</b>
3.1	Valve Identification	15
3.2	Design of the Valve	17
3.3	Sealing Concepts	18
3.3.1	"Shrink-on Fit" Version	18
3.3.2	"Divisible" Version - for Hard Sealing Materials	18
3.3.3	"Divisible" Version - for Elastomer Sealing Materials	18
<b>4</b>	<b>Transport and storage</b>	<b>19</b>
4.1	Storage conditions	19
4.2	Transport	19
4.2.1	Scope of supply	19
<b>5</b>	<b>Technical data</b>	<b>20</b>
5.1	Technical data	20
<b>6</b>	<b>Assembly and installation</b>	<b>22</b>
6.1	Safety instructions	22
6.2	Notes on installation	22
6.3	Welding In a Valve with Pipe Connection	22
6.3.1	Welding In and Installing a Valve	22
6.3.2	Welding post-treatment	23
6.4	Welding valve with flange connection into the tank	24
6.4.1	Welding tools	24
	Welding tool type O	24
	Welding tool type S	24
6.4.2	Welding In and Installing a Valve	25
6.4.3	Welding Instructions	26
	Welding sequence	28
6.4.4	Welding post-treatment	29
6.5	Pneumatic connections	29
6.5.1	Air Requirement	29
6.5.2	Establishing the Compressed Air Supply	30
6.6	Electrical connections	31
<b>7</b>	<b>Start-up</b>	<b>32</b>
7.1	Safety instructions	32

7.2	Notes on commissioning	32
<b>8</b>	<b>Operation and control</b>	<b>33</b>
8.1	Safety instructions	33
<b>9</b>	<b>Cleaning</b>	<b>34</b>
9.1	Cleaning	34
9.2	Sterilisation	34
9.3	Passivation	34
<b>10</b>	<b>Maintenance</b>	<b>36</b>
10.1	Safety instructions	36
10.2	Inspections	37
10.2.1	Bellows	37
10.2.2	Pneumatic connections	37
10.2.3	Electrical connections	37
10.3	Maintenance intervals	37
10.4	List of tools	38
10.5	Prior to disassembly	42
10.6	Disassembling and Assembling the Valve	43
10.6.1	Disassembling the Valve	43
10.6.2	Assembling the Valve	44
10.6.3	Torques for clamp	46
10.7	Disassembling and Assembling the Internal Assembly	46
10.7.1	Disassembling the Internal Assembly	46
10.7.2	Assembling the Internal Assembly	47
10.8	Removing and Installing the "Shrunk-on" Valve Seat Seal	47
10.8.1	Removing the Shrunk-on Valve Seat Seal	47
10.8.2	Fitting the Shrunk-on Valve Seat Seal	48
10.9	Removing and Installing the "Divisible System" Valve Seat Seal	50
10.9.1	Removing the Divisible Valve Seat Seal	50
10.9.2	Fitting the Divisible Valve Seat Seal	52
10.9.3	Torques for Divisible Valve discs	52
10.10	Carrying out the "Internal Assembly" Leak Test (Bubble Test)	52
10.11	Disassembling and Assembling Actuator PA50/PA60	54
10.11.1	Disassembling Actuator PA50/PA60	54
10.11.2	Assembling Actuator PA50/PA60	59
10.12	Disassembling and Assembling Actuator PA80 - PA255	59
10.12.1	Disassembling Actuator PA80 - PA255	59
10.12.2	Assembling Actuator PA80 - PA255	62
10.13	Disassembling and Assembling Actuator PA80AZ - PA180AZ	64
10.13.1	Disassembling Actuator PA80AZ - PA180AZ	64
10.13.2	Assembling Actuator PA80AZ - PA180AZ	67
10.14	Maintenance	67
10.15	Checking the Feedback Unit	69
10.15.1	Setting the Feedback Unit	69
10.15.2	Valve Stroke	69
<b>11</b>	<b>Alarms</b>	<b>71</b>
11.1	Malfunctions and remedies	71
<b>12</b>	<b>Decommissioning</b>	<b>73</b>
12.1	Safety instructions	73
12.2	Disposal	73
12.2.1	General notes	73
<b>13</b>	<b>Appendix</b>	<b>74</b>
13.1	Lists	74
13.1.1	Abbreviations and terms	74

# 1 General Information

## 1.1 Information on the Document

The present Operating Instructions are part of the user information for the product. The Operating Instructions contain all the information you need to transport, install, commission, operate and carry out maintenance for the product.

### 1.1.1 Binding Character of These Operating Instructions

These Operating Instructions contain the manufacturer's instructions to the operator of the product and to all persons who work on or use the product regarding the procedures to follow.

Carefully read these Operating Instructions before starting any work on or using the product. Your personal safety and the safety of the product can only be ensured if you act as described in the Operating Instructions.

Store the Operating Instructions in such a way that they are accessible to the operator and the operating staff during the entire life cycle of the product. When the location is changed or the product is sold make sure you also provide the Operating Instructions.

### 1.1.2 Notes on the Illustrations

The illustrations in these Operating Instructions show the product in a simplified form. The actual design of the product can differ from the illustration. For detailed views and dimensions of the product please refer to the design documents.

### 1.1.3 Symbols and Highlighting

In these Operating Instructions, important information is highlighted by symbols or special formatting. The following examples illustrate the most important types of highlighting.



#### **Danger**

##### **Warning: Fatal Injuries**

Failure to observe the warning can result in serious damage to health, or even death.

- ▶ The arrow identifies a precautionary measure you have to take to avoid the hazard.



##### **Warning: Explosions**

Failure to observe the warning can result in severe explosions.

- ▶ The arrow identifies a precautionary measure you have to take to avoid the hazard.

 **Warning!**

**Warning: Serious Injuries**

Failure to observe the warning can result in serious damage to health.

- ▶ The arrow identifies a precautionary measure you have to take to avoid the hazard.

 **Caution!**

**Warning: Injuries**

Failure to observe the warning can result in minor or moderate damage to health.

- ▶ The arrow identifies a precautionary measure you have to take to avoid the hazard.

**Notice!**

**Warning: Damage to Property**

Failure to observe the warning can result in serious damage to the component or in the vicinity of the component.

- ▶ The arrow identifies a precautionary measure you have to take to avoid the hazard.

Carry out the following steps: = Start of a set of instructions.

1. First step in a sequence of operations.
  2. Second step in a sequence of operations.
    - Result of the previous operation.
- The operation is complete, the goal has been achieved.

---

 **Hint!**

**Further useful information.**

---

**1.2 Manufacturer address**

GEA Aseptomag AG  
Industrie Neuhof 28  
CH-3422 Kirchberg

**1.3 Customer service**

Phone: +41 (0)34 426 29 29  
Fax: +41 (0)34 426 29 28  
service.aseptomag@gea.com  
www.gea.com

## 1.4 EC Declaration of Incorporation



Kirchberg, 16.12.16

# Declaration of Incorporation

## According 2006/42/EC from 09.06.2006, appendix II B

**INCORPORATION OF PARTLY COMPLETED MACHINERY**

We herewith declare that the subsequently described partly completed machine complies with the below listed essential requirements of the machine directive 2006/42/EC. The technical documentation is compiled in accordance with part B of Annex VII. In response to reasonable request the relevant technical documentation will be provided to the national authorities in printed or electronic format (PDF).

Manufacturer:	<b>GEA Aseptomag AG Industrie Neuhof 28 CH-3422 Kirchberg</b>
Authorized person:	<b>GEA Aseptomag AG Engineering Department Industrie Neuhof 28 CH-3422 Kirchberg</b>
Commercial name of the machine:	<b>Valve</b>
Machine type:	<b>Aseptomag® Valve Technology</b>
Serial number:	<b>xxxx yy (x = serially numbered, y = year of manufacture)</b>
Respective EC standard:	<b>2006/42/EC</b>
Essential requirements:	<b>Appendix I, section 1 and 2.1</b>
Applied harmonized standards:	<b>DIN EN ISO 12100:2010</b>

The commissioning of this partly completed machine is prohibited until the final machinery into which it is to be incorporated has been declared in conformity with the provisions of the Machine Directive 2006/42/EC.



**Reimar Gutte**  
Management Board  
GEA Aseptomag AG



**i.A. Aron Stauffer**  
Teamleader Product Development  
Flow Components – Aseptic Valves

**GEA Aseptomag AG**  
Tel. +41 34 426 29 29 · Fax +41 34 426 29 28 · gea.com  
Industrie Neuhof 28, CH-3422 Kirchberg

Seite 1 von 1

## 2 Safety

### 2.1 Intended use

Aseptic shut-off bottom seat valves are stroke valves and are used primarily for opening and closing tanks in aseptic process plants in a controlled manner. Another application of aseptic bottom-seat valves is to shut off piping in aseptic installations where the valve must be suspended. A welded stainless steel bellows (or PTFE bellows as an option) is used to hermetically seal the valve disc. Selected sealing materials in the product chamber ensure optimum tightness. The valve offers a high degree of process reliability and product quality in aseptic working processes.

Pressure hammers and excessive control air pressures can destroy the bellows. The control air pressure should therefore not exceed 8 bar and pressure hammers in the system should be avoided.

The shut-off bottom seat valve (AVBS) should close against the direction of flow of the medium if possible. Should this not be possible due to technical reasons related to the plant or process, the valve must be depressurized. Both measures prevent pressure hammers when the valve is opened or closed. The valve is monitored, controlled and operated by the customer's system.



#### Hint!

**The manufacturer will not accept any liability for damage resulting from any use of the valve which is not in accordance with the designated use of the valve. The risk of such misuse lies entirely with the operator of the facility.**

---

#### 2.1.1 Requirements for operation

The prerequisite for reliable and safe operation of the component is proper transportation and storage as well as professional installation and assembly. Operating the unit within the limits of its designated use also involves adhering to the operating, inspection and maintenance instructions.

#### 2.1.2 Pressure equipment directive

The valve is a piece of pressure equipment (without safety function) as defined in the Pressure Equipment Directive: Directive 2014/68/EG. It is classified according to Annex II, article 4, section 3. In the event of any deviations, GEA Aseptomag AG will supply a specific Declaration of Conformity.

#### 2.1.3 ATEX directive

Aseptomag<sup>®</sup> valve technology can also be used in ATEX protected areas. However, the suitability of the component must be checked under consideration of the respective conditions. Additional information will be made available upon request.

#### 2.1.4 Improper operating conditions

The operational reliability of the valve cannot be ensured under improper operating conditions. Therefore avoid improper operating conditions.

Operating the valve is not permitted if

- Persons or objects are in the danger zone.
- Safety devices are not working or were removed.
- Malfunctions have been detected on the valve.
- Damage has been detected on the valve.
- Maintenance intervals have been exceeded.

## 2.2 Operator's Duty of Care

In your capacity as operator of the facility you bear a particular responsibility for the proper and safe handling of the valve in your facility. Only use the valve when it is in perfect condition to prevent danger to persons and property.

These Operating Instructions contain the information you and your staff need for the safe and reliable operation during the entire service life of the valve. Be sure to read these Operating Instructions carefully and ensure that the measures described here are observed.

The operator's duty of care includes planning the necessary safety measures and monitoring that these measures are observed. The following principles apply:

- Only allow qualified staff to work on the valve.
- The operator must authorize the staff to carry out the relevant tasks.
- Working areas and the entire environment of the valve must be neat and clean.
- The staff must wear suitable work clothing and personal protective equipment. As the operator of the facility make sure that work clothing and personal protective equipment are used.
- Instruct the staff with regard to any properties of the product which might pose a health risk and the preventative measures to be taken.
- Have a qualified first-aider on call during the operation, who can initiate the necessary first-aid measures in case of an emergency.
- Clearly define processes, lines of authority and responsibilities associated with the valve. Everybody must know what to do in case of an emergency. Instruct the staff in this respect at regular intervals.
- The signs relating to the valve must always be complete and legible. Check, clean and replace the signs as necessary at regular intervals.
- Observe the Technical Data specified and the limits of use!



### **Hint!**

**Carry out regular checks. This way you can ensure that these measures are actually observed.**

---

## 2.3 Subsequent changes

You should never make any technical modifications to the valve. Otherwise you will have to undergo a new conformity process in accordance with the EC Machinery Directive on your own.

In general, only original spare parts supplied by GEA Aseptomag AG should be fitted. This ensures the reliable and economical operation of the valve.

## 2.4 General safety instructions and dangers

The valve is operationally reliable. It was built according to state-of-the-art science and technology.

Nevertheless, the valve can pose dangers, especially if

- the valve is not used in accordance with its intended use,
- the valve is not used correctly,
- the valve is operated under impermissible operating conditions.

### 2.4.1 Principles for safe operation

Dangerous situations during operation can be avoided by safety-conscious and proactive behaviour of the staff.

To ensure safe operation of the valve the following principles apply:

- The Operating Instructions must be kept ready to hand at the valve's place of use. They must be complete and in clearly legible form.
- Only use the valve for its intended use.
- The valve must be functional and in good working order. Check the condition of the valve before starting work and at regular intervals.
- Wear tight-fitting work clothing for all work on the valve.
- Ensure that nobody can get hurt on the parts of the valve.
- Immediately report any faults or noticeable changes on the valve to the person responsible.
- Never touch the pipes and the valve when these components are hot! Avoid opening the valve unless the process plants have been emptied and depressurised.
- Observe the accident prevention regulations and all local regulations.

### 2.4.2 Environmental Protection

Harm to the environment can be avoided by safety-conscious and proactive behaviour of the staff.

For environmental protection the following principles apply:

- Substances harmful to the environment must not be discharged into the ground or the sewage system.
- Always observe the pertinent regulations relating to waste avoidance, disposal and utilization.

- Substances harmful to the environment must be collected and stored in suitable containers. Clearly mark the containers.
- Dispose of lubricants as hazardous waste.

### **2.4.3 Electrical Equipment**

For all work on electrical equipment, the following principles apply:

- Access to electrical equipment should only be allowed to qualified electricians. Always keep unattended switch cabinets locked.
- Modifications of the control system can affect the safe and reliable operation. Modifications are only permitted with the express permission of the manufacturer.
- After completion of all work, check that the protective devices are fully functional.

### **2.5 Supplementary Regulations**

In addition to the instructions in this documentation the following also has to be observed:

- pertinent accident prevention regulations,
- generally accepted safety rules,
- national regulations applicable in the country of use,
- work and safety instructions applicable in the facility,
- installation and operating regulations for use in potentially explosive areas.

### **2.6 Qualification of Staff**

This section contains information about the qualifications that staff working on the valve must have.

Operating and maintenance staff must

- have the necessary qualification to carry out their tasks,
- be instructed with regard to possible dangers,
- know and observe the safety instructions given in the documentation.

Only allow qualified electricians to carry out work on the electrical equipment or have a qualified electrician supervise the work.

Only allow specially trained staff to carry out any work on explosion-protected equipment. When working on explosion-protected equipment observe the standards DIN EN 60079-14 for gases and DIN EN 50281-1-2 for dusts.

The following minimum qualifications are required:

- Vocational training as a specialist who can work on the valve independently.
- Sufficient instruction to work on the valve under the supervision and direction of a qualified specialist.

Each member of staff must meet the following requirements to be allowed to work on the valve:

- Personal qualification for the relevant task.
- Sufficient professional qualification for the relevant task.
- Instructed with regard to the function of the valve.
- Instructed with regard to the operating sequences of the valve.
- Familiar with the safety devices and their function.
- Familiar with these Operating Instructions, especially with the safety instructions and the information which is relevant for the task on hand.
- Familiar with the basic regulations with regard to occupational health and safety and accident prevention.

For work to be carried out on the valve the following user groups are distinguished:

User groups	
Staff	Qualifications
Operating staff	Adequate instruction and sound knowledge in the following areas: <ul style="list-style-type: none"><li>• Function of the valve</li><li>• Valve operating sequences</li><li>• What to do in case of an emergency</li><li>• Lines of authority and responsibilities with respect to the task</li></ul>
Maintenance staff	Adequate instruction as well as sound knowledge of the design and function of the valve. Sound knowledge in the following areas: <ul style="list-style-type: none"><li>• Mechanical equipment</li><li>• Electrical equipment</li><li>• Pneumatic system</li></ul> Authorization with regard to safety engineering standards to carry out the following tasks: <ul style="list-style-type: none"><li>• Setting devices into operation</li><li>• Earthing of devices</li><li>• Marking of devices</li></ul> The relevant certificates of qualification must be submitted before work can be carried out on ATEX certified machines.

## 2.7 Safety equipment

### 2.7.1 Signage

No warning signs are affixed to this valve.

## 2.8 Residual dangers

Dangerous situations can be avoided by safety-conscious and proactive behaviour of the personnel and by wearing personal protective equipment.

Residual dangers on the valve and measures		
Danger	Cause	Measure
Danger to life	Inadvertent switch-on of the valve	Effectively disconnect all components, effectively prevent switch-on.
	Electric power	Observe the following safety rules: <ol style="list-style-type: none"> <li>1. Isolate from the power supply.</li> <li>2. Take appropriate measures to prevent switch on.</li> <li>3. Test absence of voltage.</li> <li>4. Earthing and short-circuiting.</li> <li>5. Cover or safeguard any adjacent live parts.</li> </ol>
Danger of injury	Danger presented by moving or sharp-edged parts	The operator must exercise caution and prudence. For all work: <ul style="list-style-type: none"> <li>• Wear suitable work clothing.</li> <li>• Never operate the machine if the cover panels are not correctly fitted.</li> <li>• Never open the cover panels during the operation.</li> <li>• Never reach into openings.</li> </ul> As a precautionary measure, wear personal protective equipment in the vicinity of the valve: <ul style="list-style-type: none"> <li>• Protective gloves</li> <li>• Safety shoes</li> </ul>
Environmental damage	Operating materials with properties which are harmful to the environment	For all work: <ul style="list-style-type: none"> <li>• Collect lubricants and cleaning solutions in suitable containers.</li> <li>• Dispose of lubricants and cleaning solutions in accordance with the pertinent regulations.</li> </ul>

## 2.9 Danger zones

Please observe the following notes:

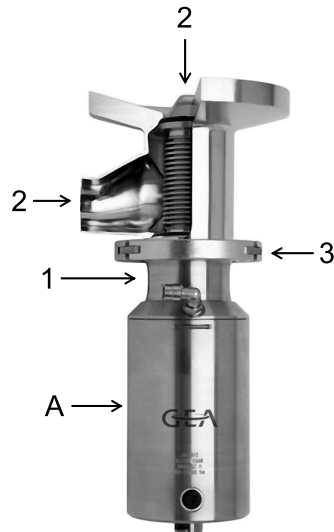

Fig.1: Danger zone at the valve

- In the event of malfunctions, shut down the valve (disconnect from the power and air supply) and secure it against being used.
- Never reach into the motor stool (1) or the valve housing (2) when the valve is switching. There is a danger of injury to fingers.
- On a spring-closing valve there is danger of injury when the clamp (3) is opened as the released spring pretension will suddenly lower the actuator. Therefore, release the spring tension by opening the valve before detaching the clamp (3) by supplying the actuator (A) with compressed air.
- Before starting any service, maintenance or repair work, disconnect the valve from the power supply and secure it against inadvertently being switched back on again.
- Only allow a qualified electrician to carry out any work on the electrical power supply.
- Check the electrical equipment of the valve at regular intervals. Immediately remedy loose connections and molten cables.
- If work on live parts cannot be avoided, call in a second person, who can operate the main switch in case of an emergency.
- The housing sockets have very sharp edges. When transporting and assembling the valve be sure to wear suitable protective gloves.

### 3 Description

#### 3.1 Valve Identification

Reference numbers from the following number systems are assigned to each part of components from GEA Aseptomag AG. The reference numbers can be used to clearly identify a component and its composition.

Number (example)	Designation	Description
0001 14	Serial valve number	The valve serial number is the easiest and most definite way to identify a component from GEA Aseptomag AG. This number is unique and allows all components installed at the time of delivery to be identified. The first four digits represent a chronological, ascending number, the last two digits provide information about the year of manufacture. The valve's serial number is indicated on a round white sticker affixed to the actuator.
0001 14	Serial number main components	The serial number has the same structure as the valve's serial number, but it is placed on the relevant main component (housing, internal assembly, actuator) by laser marking / stamping.
V-50-1001	Drawing number	The drawing number is a combination of two groups. The digits in front of the hyphen refer to where the components belong to. The next four numbers describe the part in more detail. For this purpose, the main component groups of a valve are assigned to various groups: <ul style="list-style-type: none"> <li>• V-xx-0xxx = entire valves</li> <li>• V-xx-1xxx = valve housings</li> <li>• V-xx-2xxx = internal assemblies</li> <li>• V-xx-3xxx = actuators</li> <li>• V-xx-4xxx = feedback units / accessories</li> </ul>

An AVBS shut-off bottom seat valve consists of four main components:

- Valve housing
- Internal assembly
- Actuator
- Clamp

Each of these main components is marked and can be uniquely identified.

! Other markings on components of the valve, such as on connectors, arise from the production process and are not relevant.

**Description**  
Valve Identification

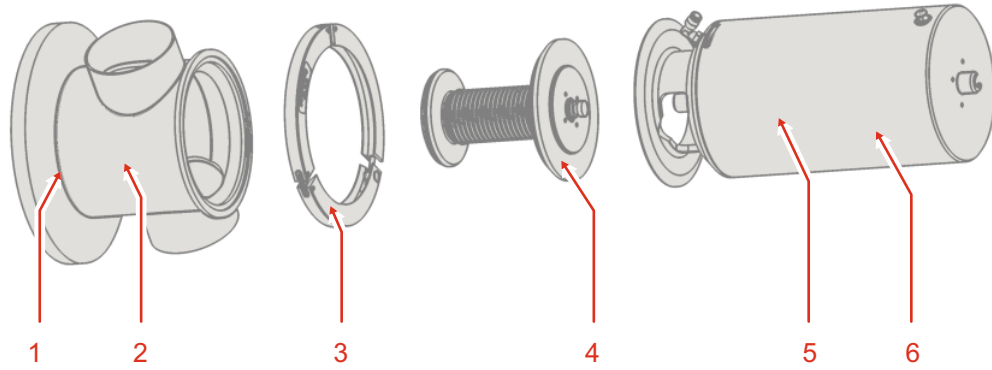

Fig.2: Designations on the valve

Key			
No.	Example	Position	Details
1	V-50-1084 1.4435 TC 333937	Valve housing	Drawing number of valve housing Material and re-stamping details
2	0548 10	Valve housing	Serial number of valve housing
3	V-50-1004	Clamp	Number of clamp drawing
4	V-50-2147 1424 10	Internal assembly	Drawing number of internal assembly Serial number of internal assembly
5	1216 10	Actuator	Sticker with valve serial valve
6	PA100/50 NC V-50-3000 0977 10	Actuator	Designation of actuator Number of actuator drawing Serial number of actuator

### 3.2 Design of the Valve

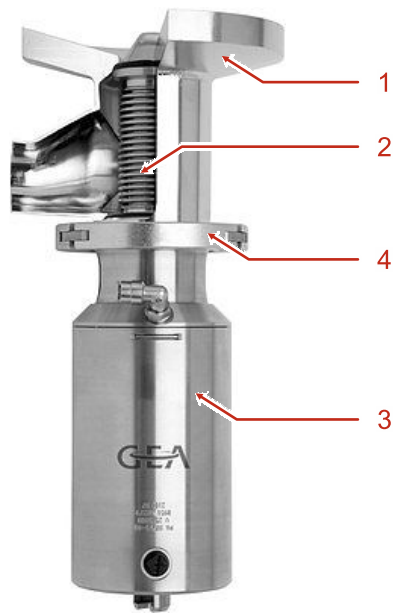

Fig.3: Main components on the valve

Key	
No.	Designation
1	Housing
2	Internal assembly
3	Actuator
4	Clamp (safety device)

### 3.3 Sealing Concepts

#### 3.3.1 "Shrink-on Fit" Version

- Undivided valve disc
- GEA Aseptomag standard
- For hard sealing materials such as TEFASEP, PTFE or reinforced PTFE



Fig.4: "Shrink-on Fit" Version

#### 3.3.2 "Divisible" Version - for Hard Sealing Materials

- Divisible valve disc
- GEA Aseptomag option
- For hard sealing materials such as TEFASEP, PTFE or reinforced PTFE
- Additional elastomer O-ring behind the valve seat seal

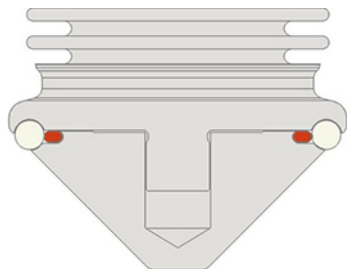

Fig.5: "Divisible" version - for hard sealing materials

#### 3.3.3 "Divisible" Version - for Elastomer Sealing Materials

- Divisible valve disc
- GEA Aseptomag option
- For elastomer sealing materials such as EPDM
- Form-gasket with moulded-on retention flag

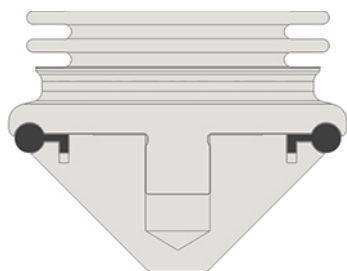

Fig.6: "Divisible" version - for elastomer sealing materials

## 4 Transport and storage

### 4.1 Storage conditions

The valves, valve inserts or spare parts should be stored in a dry place, free of vibrations and dust, and protected from light. To avoid damage, leave the components in their original packaging if possible.

If, during transport or storage, the valve is going to be exposed to temperatures  $\leq 0^{\circ}\text{C}$ , it must be dried beforehand and suitable measures must be taken to protect it from damage.



#### Hint!

**We recommend that the valve should be stored at a temperature of  $\geq 5^{\circ}\text{C}$  for a period of 24 hours prior to any handling (disassembling the housings / activation of actuators) so that any ice crystals formed by condensation water can melt.**

---

### 4.2 Transport

For transport, the following principles apply:

- Only use suitable lifting gear and slings for transporting the package units/ valves.
- Observe the pictograms on the package.
- Handle valves with care to avoid damage caused by impact or careless loading and unloading. The outside synthetic materials are susceptible to breaking.
- Control tops (if fitted) must be protected from animal and vegetable fats.
- Only allow qualified staff to transport the valve.
- Movable parts must be properly secured.
- Only use approved, fully functional load lifting devices and lifting accessories which are suitable for the intended purpose. Observe the maximum load-bearing capacities.
- Secure the valve against slipping. Take the weight of the valve into account and the position of the point of gravity.
- Under no circumstances should anyone stand under a suspended load.
- Take care when transporting the valve. Do not grip sensitive parts of the unit to lift or push the unit or to support yourself. Avoid putting the unit down with a jerk.

#### 4.2.1 Scope of supply

On receipt of the valve check whether

- the details on the main valve components correspond to the data in the order and delivery documents,
- the equipment is complete and all components are in good order.

## 5 Technical data

### 5.1 Technical data

Operating data (for valve with sealing materials Tefasep and silicone)	
Max. operating temperature	150 °C (302 °F)
Max. sterilisation temperature	160 °C (320 °F) for max. 30 min.
Max. product pressure	5 ... 6 bar (others on request)
Control air pressure, actuator	6 bar, max. 8 bar
Nominal pressure	10 bar

Materials	
Parts in contact with product	1.4404 (AISI 316L) 1.4435 (AISI 316L) 1.4571 (AISI 316TI)
Actuator (exterior area)	1.4301 (AISI 304) 1.4305 (AISI 304)
Valve seat seal (product-contacting)	TEFASEP PTFE EPDM
Gasket (product-contacting)	Silicone EPDM FEP silicone
Other materials in accordance with the valve specification.	

Surface finish	
Inside areas in contact with product	Surface roughness $R_a \leq 0.8 \mu\text{m}$ (standard)
Outer surfaces	Metal blank fine turned and/or polished
Inside areas (with the exception of the metal bellows) in contact with product can be electropolished/passivated or ground on request. These methods will bring up surface roughness to $R_a \leq 0.6 \mu\text{m} / 0.4 \mu\text{m}$ .	

Resistance of sealing materials	
Product contact seals	The resistance of sealing materials depends on the type and temperature of the medium conveyed. The exposure time can adversely affect the service life of the seals. The sealing materials comply with the regulations of FDA 21 CFR 177.2600 or FDA 21 CFR 177.1550.

Compressed air supply	
Compressed air supply	6 bar, compressed air filtered (at least 0,5 µm), oil-free.

Cleaning	
Cleaning	The valve is suitable for CIP cleaning (Cleaning in Place)
Recommended cleaning speed in the valve	At least 2 m/s

Sterilisation	
Sterilisation	The valve is suitable for SIP sterilisation (Sterilisation in Place)
Sterilisation with	Hot water, max. 160 °C (320 °F) Steam, max. 160 °C (320 °F) Chemicals (e.g. H <sub>2</sub> O <sub>2</sub> )

## 6 Assembly and installation

### 6.1 Safety instructions

Dangerous situations during assembly can be avoided by safety-conscious and proactive behaviour of the staff.

For installation, the following principles apply:

- Only properly qualified staff is allowed to install, assemble and set the valve into operation.
- Ensure that adequate working and traffic areas are available at the place of installation.
- Observe the maximum load-bearing capacity of the installation surface.
- Observe the transport instructions and markings on the part(s) to be transported.
- Remove any nails protruding from transport crates immediately after opening the crate.
- Under no circumstances should anyone stand under a suspended load.
- During assembly, the valve safety devices might not be working effectively.
- Reliably secure sections of the plant which have already been connected against inadvertently being switched on.

### 6.2 Notes on installation

The valve must be installed so that the housing can drain on its own.

To prevent damage, make sure that

- the valve is installed in the tank or in the pipe system free of tension and
- no foreign materials (e.g. tools, bolts, lubricants) are left in the system.
- the valve is installed so that the flow is directed against the valve disc.
- the valve is ideally installed in vertical position.

### 6.3 Welding In a Valve with Pipe Connection

#### 6.3.1 Welding In and Installing a Valve

This section describes how you weld in a valve with pipe connection.

Prerequisite:

- For valves with welding ends: Actuator and internal assembly have been removed, see Section 10.6, Page 43.

 **Caution!**

**Danger of injury due to spring force being released**

You can sustain injuries to your fingers when you put your hand into a valve if the valve has not been moved to the open position beforehand.

- ▶ Before starting any work, bring the valve to the "open" position.
- ▶ Wear protective gloves for all work.
- ▶ Always exercise caution and prudence.

 **Caution!**

**If pipes contain liquids, these can spurt out when the pipes are opened.**

Danger of injury as a result of hot or aggressive liquids.

- ▶ Drain all pipe system elements that lead to the valve location and, if necessary, clean or rinse them.
- ▶ Separate the pipe section in which the valve is to be fitted from the rest of the piping system to prevent medium from entering again.

---

Carry out the following steps:

1. Saw the pipe ends flat and square, deburr and degrease them.
2. Prepare the component housing so that the component housing can be welded into position free from stress and distortion.
3. Prepare the welding procedure: use the 141 TIG (tungsten inert gas) welding method with butt weld. I-joint according to DIN8532; hand or orbital weld.
4. Connect the forming gas.
5. Tack the component housing at several points distributed around the circumference under forming gas (ensure forming gas supply).  

! Adjoining welding ends must not be separated by a gap. Otherwise the corrosion resistance of the welded joint and the pipe will be reduced when forming gas flows out.
6. Weld the housing into the pipe system.  
→ The valve has been welded in and installed.

### 6.3.2 Welding post-treatment

#### Interior

As long as forming and welding were carried out professionally, post-treatment of the interior surfaces is not necessary.

#### Exterior area

Depending on the requirements, post-treatment in the exterior area consists of:

- pickling,
- grinding,
- brushing,

## Assembly and installation

Welding valve with flange connection into the tank

- polishing.

### 6.4 Welding valve with flange connection into the tank

#### 6.4.1 Welding tools

When welding in a valve with flange connection, it is generally advisable to use welding tools for optimum heat dissipation to prevent distortion.

The following welding tools are provided by GEA Aseptomag AG on request:

##### 6.4.1.1 Welding tool type O

The type O welding tool is used in loose weld-in tank flanges.

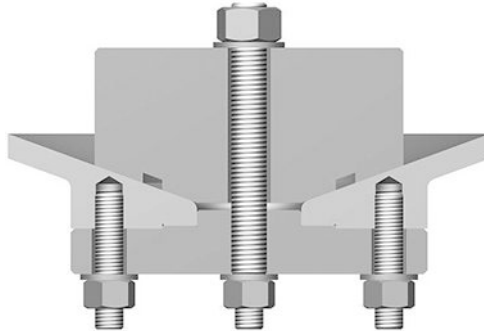

Fig.7: Welding tool type O

Welding tools for aseptic shut-off bottom seat valve AVBS type O			
	Nominal width		Welding device
	DN	OD	
Welding tool, complete (20°)	25	1"	S12-0631
	40	1 1/2"	S12-0745
	50	2"	S12-0483
	65	2 1/2"	S12-0421
	80	3"	S12-0733

##### 6.4.1.2 Welding tool type S

The type S welding tool is used with integral weld-in tank flanges in the housing.

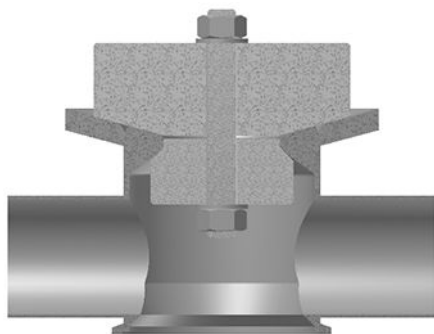

Fig.8: Welding tool type S

Welding tools for aseptic shut-off bottom seat valve AVBS type S			
	Nominal width		Welding device
	DN	OD	
Welding tool, complete (15°)	25	1"	S12-0717
	40	1 1/2"	S12-0053
	50	2"	S12-0068
	65	2 1/2"	S12-0025
	80	3"	S12-0479

#### 6.4.2 Welding In and Installing a Valve

This section describes how to weld a valve with flange connection into the tank.

Prerequisite:

- For valves with welding ends: Actuator and internal assembly have been removed, see Section 10.6.1, Page 43.
- For valves with loose tank flange: The valve is not bolted to the tank flange and the screws and washers have been removed.

**⚠ Caution!**

**Danger of injury due to spring force being released**

You can sustain injuries to your fingers when you put your hand into a valve if the valve has not been moved to the open position beforehand.

- ▶ Before starting any work, bring the valve to the "open" position.
- ▶ Wear protective gloves for all work.
- ▶ Always exercise caution and prudence.

**Notice!**

**Damage caused by welding**

The tank bottom valve can be damaged by distortion due to welding and when the position of the grooves is altered.

- ▶ Before starting any welding work, remove all built-in parts from the valve.
  - ▶ To ensure that a proper weld is formed when the valve is welded into the pipe, make sure that the root side of the weld is protected against oxidation by forming gas.
  - ▶ Use welding filler if necessary.
- 

Carry out the following steps:

1. Make the tank bore according to the valve specification with a maximum tolerance of  $d+0.5$  mm.  
! If the sheet thickness is appropriate, prepare a V-seam.
2. Fit suitable welding tool.
3. Tack flange crosswise (see welding instruction Section 6.4.3, Page 26).  
→ This approach ensures virtually distortion-free welding.
4. Prepare the welding procedure: use the 141 TIG (tungsten inert gas) welding method.  
Use only pulse welding.
5. Weld in the component housing according to the welding instructions, see Section 6.4.3, Page 26.  
→ The valve has been welded in and installed.

**6.4.3 Welding Instructions**

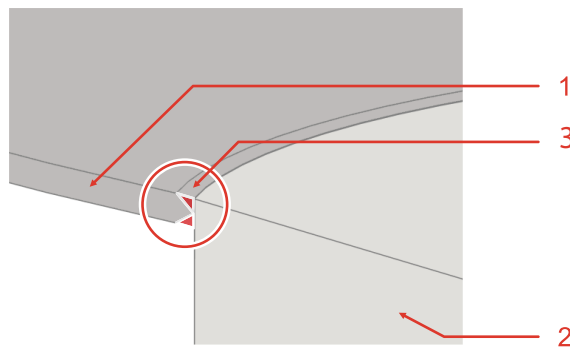

Fig.9: Weld

No.	Designation
1	Tank
2	Flange
3	K-seam

Preparatory information	
Welding method of the manufacturer	TIG pulse
Welder	certified according to DIN EN ISO 9606-1 and AD -2000 leaflet HP3
Welding process	141 DIN EN ISO 4063
Type of preparation	Mechanical
Type of cleaning	Brushing or staining
Type of seam	DIN EN ISO 9692; K-seam, gap b=0 mm
Workpiece thickness [mm]	t1 = 4, 5, 6, 8, 10
Specification of base materials	1.4404, 1.4435, 1.4539, 1.4529
Outside diameter	187; 237; 267
Heat input	Root 1, 2: < 9 kJ/cm
Heat input	Layer 3, 4: < 10 kJ/cm
Joint preparation	-
Welding position	-

Information about the welding sequence						
Bead	Process	Additional material Ø [mm]	Current [A]	Voltage [V]	Type of current/ polarity electrode	Welding speed [cm/min]
Root	141 pulse	1.2; 1.6	50 - 60	10 - 14	=/-	3-7
Cover pass	141 pulse	1.2; 1.6	50 - 60	10 - 14	=/-	3-7
Cover passes 2, 3, 4, ...	141 pulse	1.2; 1.6	105 - 125	10 - 14	=/-	3-7



**Hint!**

**Select current according to workpiece thickness t1.**

## Assembly and installation

Welding valve with flange connection into the tank

Additional materials	<ul style="list-style-type: none"><li>• 1.4430 (DIN EN 12072: 19 12 3 LSi) for base materials 1.4404 and 1.4435</li><li>• 2.4831 (EN ISO 18274: NiCr22Mo9Nb) for base materials 1.4539 and 1.4529</li></ul>
Inert gas	DIN EN ISO 14175-I1
Root protection/forming gas	DIN EN ISO 14175 -I1, -R1
Flow rates [l/min]	Inert gas: 13 - 15
	Root protection: 10 - 20
Interpass temperature	$T < 30 \text{ }^{\circ}\text{C}$

Design				
t2	h	c	$\alpha$	$\beta$
10	3.5	3	30°	30°

If the container wall thickness  $t_1 < 8 \text{ mm}$ , pass 4 can be omitted. Inside the tank, the seam preparation and the seam design are retained.

### 6.4.3.1 Welding sequence

#### Performing tacking

Carry out the following steps:

1. Always set welding points opposite. (1-2; 3-4; 5-6; 7-8).  
→ This approach ensures distortion-free welding.

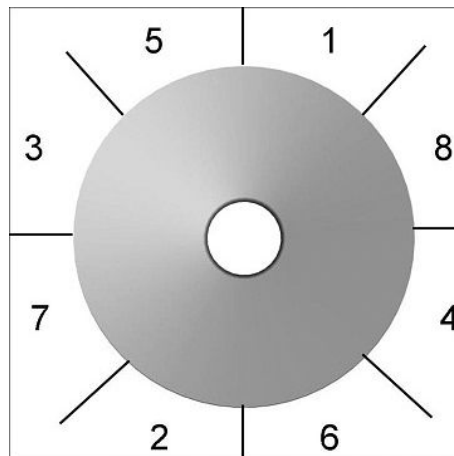

Fig.10: Tacking sequence

→ Tacking has been performed.

#### Performing welding inside/outside

Carry out the following steps:

1. Weld flange to the tank.
  - Reduce current to minimum to minimise heating.
  - Weld root without additive if possible.
  - Weld cover layers with additive (number of cover layers depending on material thickness).
  - Weld only with a device connected to forming gas.
  - Weld using the "pilgrim step method".
2. After each weld, cool the weld with water or air.
  - The valve has been welded in and installed.

#### 6.4.4 Welding post-treatment

##### Exterior area

Depending on the requirements, post-treatment in the exterior area consists of:

- pickling,
- brushing,
- grinding,
- polishing.

##### Container inside

The welding post-treatment on the inside of the container is carried out by grinding and polishing according to the technical requirements.

### 6.5 Pneumatic connections

#### 6.5.1 Air Requirement

The air requirement depends on the type of actuator fitted. The following tables show guideline values at an air pressure supply of 6 bar per valve size and the corresponding actuator size used as a standard.

Air requirement for spring-to-close actuators (NC)				
Nominal width of valve	Actuator	Reference stroke (RH1)	Reference air pressure (RL1)	Air requirement at RH1/RL1
		[mm]	[bar]	[dm <sup>3</sup> ]
DN 10 / 1/2" OD	PA60 NC	6	6	0.3
DN 15 / 3/4" OD	PA60 NC	6	6	0.3
DN 25 / 1" OD	PA80 NC	10	6	0.9
DN 40 / 1 1/2" OD	PA80 NC	12.5	6	0.9
DN 50 / 2" OD	PA100 NC	25	6	2.2
DN 65 / 2 1/2" OD	PA100 NC	25	6	2.2

Air requirement for spring-to-close actuators (NC)				
Nominal width of valve	Actuator	Reference stroke (RH1)	Reference air pressure (RL1)	Air requirement at RH1/RL1
		[mm]	[bar]	[dm <sup>3</sup> ]
DN 80 / 3" OD	PA135 NC	25	6	3.8
DN 100 / 4" OD	PA180 NC	25	6	7.8
DN 125	PA255 NC	35	6	20.3
DN 150 / 6" OD	PA255 NC	35	6	20.3

Air requirement for spring-to-open actuators (NO)				
Nominal width of valve	Actuator	Reference stroke (RH1)	Reference air pressure (RL1)	Air requirement at RH1/RL1
		[mm]	[bar]	[dm <sup>3</sup> ]
DN 10 / 1/2" OD	PA60 NO	6	6	0.3
DN 15 / 3/4" OD	PA60 NO	6	6	0.3
DN 25 / 1" OD	PA80 NO	10	6	0.8
DN 40 / 1 1/2" OD	PA80 NO	12.5	6	0.8
DN 50 / 2" OD	PA100 NO	25	6	2.2
DN 65 / 2 1/2" OD	PA100 NO	25	6	2.2
DN 80 / 3" OD	PA135 NO	25	6	4.0
DN 100 / 4" OD	PA180 NO	25	6	8.0
DN 125	PA255 NO	35	6	20.2
DN 150 / 6" OD	PA255 NO	35	6	20.2

### 6.5.2 Establishing the Compressed Air Supply

A prerequisite for the reliable operation of the valve is that the compressed air hoses are cut exactly square.

Tools required:

- A hose cutter

Carry out the following steps:

1. Depressurize the pneumatic connection at the place where you are working.
2. Use the hose cutter to cut the pneumatic hoses square.
3. Connect a hose to the valve.

→ The compressed air supply has been established.

## 6.6 Electrical connections

Prerequisite:

- The valve has been fitted correctly, see Section 10.6.2, Page 44.



### **Danger**

#### **Live parts**

Electrical shock can result in serious personal injury or death.

- ▶ Only allow properly qualified staff to carry out work on the electrical equipment.
- ▶ Prior to establishing electrical connections check the maximum permissible operating voltage.



#### **Explosive gases or dusts**

An explosion can result in serious personal injury or death.

- ▶ Observe the installation and operating regulations for use in potentially explosive areas.

Carry out the following steps:

1. Connect in accordance with the control top diagram and the instructions in the corresponding operating instructions for the T.VIS control top or other models.
- The valve has been connected electrically.

## 7 Start-up

### 7.1 Safety instructions

#### Initial commissioning

For initial commissioning, the following principles apply:

- Take protective measures against dangerous contact voltages in accordance with pertinent regulations.
- The valve must be completely assembled and correctly adjusted. All screw connections must be securely tightened. All electrical cables must be installed correctly.
- Reliably secure machine parts which have already been connected against inadvertently being switched on.
- Relubricate all lubricating points.
- Make sure lubricants are used properly.
- After conversion of the valve, residual risks must be reassessed.

#### Setting into Operation

For commissioning, the following principles apply:

- Only allow properly qualified staff to set the valve into operation.
- Establish all connections correctly.
- The safety devices for the valve must be complete, fully functional and in perfect condition. Check the function before starting any work.
- When the valve is switched on, the danger zones must be free.
- Remove any liquids that have escaped without leaving residues.

### 7.2 Notes on commissioning

Before starting commissioning observe the following:

- Make sure that there are no foreign materials in the system.
- Actuate all positions of the valve once by applying compressed air.
- When TEFASEP is used as a sealing material, the valve must be sterilised before the first product run and briefly brought to the closed position immediately after sterilisation to ensure optimum tightness. For detailed information, see Section 9.2, Page 34
- Clean and sterilise the pipe system prior to the first product run.
- During commissioning, regularly check all sealing points for leaks. Replace defective seals.

## 8 Operation and control

### 8.1 Safety instructions

Dangerous situations during operation can be avoided by safety-conscious and proactive behaviour of the staff.

For operation, the following principles apply:

- Monitor the valve during the operation.
- Safety devices must not be changed, removed or taken out of service. Check all safety devices at regular intervals.
- All guards and hoods must be fitted as intended.
- The place of installation of the valve must be adequately ventilated at all times.
- Structural alterations of the valve are not permitted. Immediately report any changes on the valve to the person responsible.
- Always keep danger zones clear. Do not leave any objects in the danger zone. Only allow persons to enter the danger zone when the machine is de-energized.
- Regularly check that all emergency stop devices are working correctly.

## 9 Cleaning

### 9.1 Cleaning

The valve is suitable for CIP (Cleaning in Place); recommended cleaning speed in the valve is at least 2 m/s.

All parts in contact with product must be cleaned at regular intervals. Always observe the safety data sheets issued by the cleaning agent manufacturers. Only use cleaning agents which do not cause damage to the seals and the inner parts of the valve. When the pipe is cleaned, the cleaning medium also flows through and cleans the valve housings.

With respect to the cleaning method and parameters like detergents, temperatures, times, and intervals, the component manufacturer can merely make recommendations but cannot provide any generally applicable details. Method and parameters should be determined and defined by the operator in accordance with the relevant process and product.

The cleaning effect must be checked regularly by the operator!

### 9.2 Sterilisation

The valve is suitable for SIP sterilisation (Sterilisation in Place). The following data applies for valves equipped with Tefasep and silicone sealing materials.

Sterilisation is possible using:

- Hot water at max. 160 °C (320 °F) for 20 to 30 min
- Steam at max. 160 °C (320 °F) for 20 to 30 min
- Chemicals (e.g. H<sub>2</sub>O<sub>2</sub>)



#### Hint!

**When TEFASEP valve seat seals are used, hot sterilisation is mandatory. Steam sterilisation allows the seal to be perfectly fitted into the valve seat, thus ensuring optimum sealing against the maximum closing pressure specified.**

#### **Operating conditions for steam sterilisation:**

- Medium: saturated steam or hot water
- Temperature: >121 °C (250 °F)
- Holding time: 20 ... 30 min

**The valve must be brought to the closed position for a brief period (min. 5 seconds) immediately after sterilisation with steam. During commissioning, regularly check all sealing points for leaks. Replace defective seals and repeat the sterilisation process.**

---

### 9.3 Passivation

Before commissioning a plant, passivation is commonly carried out for long pipes and tanks. Valve blocks are usually excepted from this.

Passivation is typically performed using nitric acid (HNO<sub>3</sub>) at approx. 80 °C (176 °F) at a concentration of 3 % and a contact time of 6 to 8 hours.

The ultimate temperatures, chemicals, concentrations and contact time to be used must be determined by the plant operator along with its chemical supplier.

## 10 Maintenance

### 10.1 Safety instructions

#### Maintenance and repair

Before starting any maintenance and repair work on the electrical devices of the valve, carry out the following steps in accordance with the "5 safety rules":

- Isolate from the power supply
- Take appropriate measures to prevent switch on
- Test absence of voltage
- Earthing and short-circuiting
- Cover or safeguard any adjacent live parts.

For maintenance and repair, the following principles apply:

- Observe the intervals specified in the maintenance schedule.
- Only allow qualified staff to carry out maintenance or repair work on the valve.
- Before starting any maintenance or repair work, the valve must be switched off and secured against being switched back on. Work may only be started once any residual energy has been discharged.
- Block access for unauthorized persons. Put up notice signs which draw attention to the maintenance or repair work going on.
- Do not climb on the valve. Use suitable access aids and working platforms.
- Wear suitable protective clothing.
- Only use suitable and undamaged tools to carry out maintenance work.
- When replacing parts only use approved, fully functional load lifting devices and lifting accessories which are suitable for the intended purpose.
- Before setting the magnetic separator back into operation, refit all safety devices as originally provided in the factory. Then check that all safety devices are working correctly.
- Make sure lubricants are used properly.
- Check pipes are firmly secured, also check for leaks and damage.
- Check that all emergency stop devices are working correctly.

#### Disassembly

For disassembly, the following principles apply:

- Only allow qualified staff to disassemble the valve.
- Before starting disassembly, the valve must be switched off and secured against being switched back on. Work may only be started once any residual energy has been discharged.
- Disconnect all power and utility lines.
- Markings, e.g. on lines, must not be removed.

- Do not climb on the valve. Use suitable access aids and working platforms.
- Mark the lines (if unmarked) prior to disassembly to ensure they are not confused when re-assembling.
- Protect open line ends with blind plugs against ingress of dirt.
- Pack sensitive parts separately.
- For longer periods of standstill, observe the storage conditions, see Section 4.1, Page 19.

## **10.2 Inspections**

Between the maintenance periods, the valves must be checked for leakage and proper function.

### **10.2.1 Bellows**

Carry out the following steps:

1. Check the leakage cavity for soiling and continuous leakage of fluids.  
→ The bellows has been checked.

### **10.2.2 Pneumatic connections**

Carry out the following steps:

1. Check the operating pressure at the pressure reducing and filter station.
2. Clean the air filter at regular intervals.
3. Check that the air hoses sit firmly in the air connections.
4. Check the lines for kinks and leaks.  
→ The pneumatic connection has been checked.

### **10.2.3 Electrical connections**

Carry out the following steps:

1. Check that the proximity switches are positioned correctly and the connections are clean.  
→ The electrical connection has been checked.

## **10.3 Maintenance intervals**

To ensure the highest operational reliability of the valve, all wearing parts should be replaced at longer intervals. Keep an adequate supply of all wearing parts (internal assemblies and seals) in your spare parts stock.

The actual maintenance intervals can only be determined by the user since they depend on the operating conditions, for instance:

- daily period of use,
- switching frequency,
- type and temperature of the product,

- type and temperature of the cleaning solution,
- ambient conditions.



For a detailed maintenance schedule, see Section 10.14, Page 67







**Hint!**



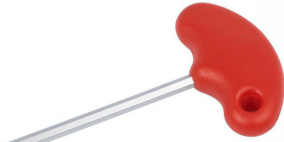

**Prior to any work on the open valve, ensure that it has stopped operation, see Section 10.5, Page 42.**





**10.4 List of tools**

List of tools (in alphabetical order)			
Tools	Figure	Intended Purpose	Material Number GEA Aseptomag AG
Pressurizing tool DN 10 - DN 80	 <p>Fig.11</p>	Valves DN 10 - DN 80 Inspection of metal bellows	0980.50003 S-12-0010
Pressurizing tool DN 80 - DN 100	 <p>Fig.12</p>	Valves DN 80 - DN 100 Inspection of metal bellows	0980.50074 S-12-0455
Pressurizing tool DN 125 - DN 150	 <p>Fig.13</p>	Valves DN 125 - DN 150 Inspection of metal bellows	0980.50073 S-12-0454

List of tools (in alphabetical order)			
Tools	Figure	Intended Purpose	Material Number GEA Aseptomag AG
Torque wrench	 Fig.14	For divisible internal assemblies	0980.50020 S-12-0086
Pressure control valve Ø 6 mm	 Fig.15	Inspection of metal bellows	9999.10090
Flexible head spanner Ø60-90mm, Pin Ø 5.5mm	 Fig.16	PA80-135 Remove/fit assembly spring	0980.10009 S-12-0332
Flexible head spanner Ø95-155mm, Pin Ø 6mm	 Fig.17	PA180-PA210 Remove/fit assembly spring	0980.50131 S-12-0568
Hand-operated press	 Fig.18	PA50 - 60 NC/NO Remove/fit PA	5050.55469 S-12-0406
Oven (no microwave, min. temp. 140 °C)	 Fig.19	Preheat hard valve seat seals	0981.50016 S-12-0084

List of tools (in alphabetical order)			
Tools	Figure	Intended Purpose	Material Number GEA Aseptomag AG
Hex socket key SW5	 Fig.20	Valves DN 10 - DN 80 Tighten/release clamp	0980.50121 S-12-0554
Hex socket key SW6		Valves DN 100 - DN 150 Tighten/release clamp	0980.50122 S-12-0555
Ratchet, square socket drive 1/2"	 Fig.21	Release divisible valve discs	0980.50124 S-12-0557
Assembly tool Spring assembly PA30-210	 Fig.22	PA30-210 Remove/insert spring assembly	0981.50008 S-12-0209
Assembly tool Spring assembly PA255		PA255 Remove/insert spring assembly	0981.50009 S-12-0210
Assembly tool Bushing PA30-60 NC/NO	 Fig.23	PA30 - 60 NC/NO Remove/fit PA	5050.50988 S-12-0233
Assembly tool Clamping device PA50-210	 Fig.24	PA50-210 Hold cylinder	5050.51064 S-12-0005

List of tools (in alphabetical order)			
Tools	Figure	Intended Purpose	Material Number GEA Aseptomag AG
Assembly tool Clamping device PA255	 Fig.25	PA255 Hold cylinder	5050.55468 S-12-0405
Assembly tool O-ring	 Fig.26	Remove/fit seals	5050.51258 S-12-0162
O-ring cutter heated	 Fig.27	Disassemble hard, shrunk valve seat seals	0980.50022 S-12-0083
Slotted screwdriver Size 1	 Fig.28	PA80AZ - PA180AZ Remove circlip from actuator base	--
Slotted screwdriver Size 4		PA80-255 Fit assembly spring	--
Vice with soft jaws or equivalent protective jaws	 Fig.29	For divisible internal assemblies and Actuators	--

List of tools (in alphabetical order)			
Tools	Figure	Intended Purpose	Material Number GEA Aseptomag AG
Protective gloves, heat-resistant	 Fig.30	Remove/fit hard valve seat seals	--
Seeger circlip pliers Inside diameter 40-100 mm, angled tip, 90°	 Fig.31	PA30 - 60 NC/NO Remove/fit PA	0980.50108 S-12-0541
Shut-off valve Ø 6 mm	 Fig.32	Inspection of metal bellows	9999.10091
Socket wrench bit a/f 13, square drive ½"	 Fig.33	Valves DN 10 - DN 100 Release divisible valve discs	0980.00009 S-12-0663
Socket wrench bit a/f 17, square drive ½"	 Fig.34	Valves DN 125 - DN 150 Release divisible valve discs	0980.00010 S-12-0664

## 10.5 Prior to disassembly

Prerequisite:

- Make sure that while work is being performed on the open valve no process is in operation in the area concerned.

Carry out the following steps:

1. Drain all pipe system elements that lead to the valve and, if necessary, clean or rinse, and also depressurize them.
2. Shut off the control air supply.

3. Disconnect the power supply.  
→ Disassembly has been prepared.

## 10.6 Disassembling and Assembling the Valve

### 10.6.1 Disassembling the Valve

Tools required:

- Hex socket key

#### **Caution!**

##### **Danger of injury due to spring force being released**

You can sustain injuries to your fingers when you put your hand into a valve if the valve has not been moved to the open position beforehand.

- ▶ Before starting any work, bring the valve to the "open" position.
- ▶ Wear protective gloves for all work.
- ▶ Always exercise caution and prudence.

#### **Caution!**

##### **Danger of injury due to media escaping after removing the clamp**

You can sustain injuries to your entire body if you open a valve that is still under pressure from the medium.

- ▶ Ensure that the valve is no longer under medium pressure before removing the clamp.
- ▶ Wear suitable protective clothing for all work.
- ▶ Always exercise caution and prudence.

Carry out the following steps:

1. Bring the valve to the "open" position.

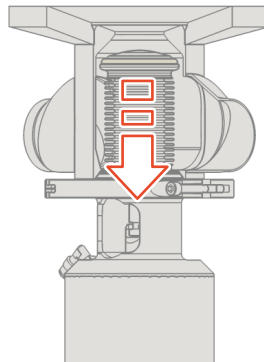

Fig.35: Apply valve NC

2. Release the clamp with a suitable hex socket key, but do not unhook the screw yet.

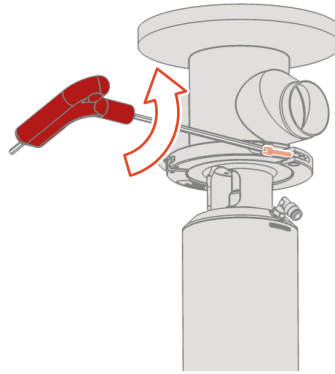

Fig.36: Loosening the clamp screw

**! Ensure that you can move the clamp by hand and without much effort before carrying out the next step. If this is not the case, carefully hit the clamp segments with a plastic mallet until the pressure is released and the clamp can easily be moved afterwards.**

3. Secure the actuator and internal assembly against sagging and falling down, and carefully remove the clamp from the valve.
4. Carefully lower the actuator with the internal assembly out of the housing.  
**! Do not damage the sealing surface on the valve body.**

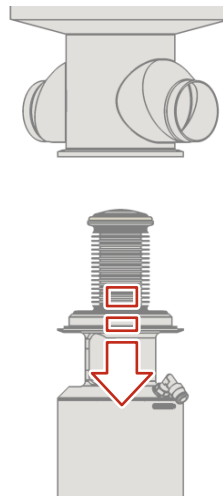

Fig.37: Removing actuator and internal assembly

→ Internal assembly and actuator are now separated from the housing.

### 10.6.2 Assembling the Valve

Tools required:

- Hex socket key

Carry out the following steps:

1. Install the valve in the reverse order of disassembly, see Section 10.6.1, Page 43.

! When attaching the clamp, tighten the screw only slightly. Make sure that the actuator and the internal assembly can be moved by hand without much effort.

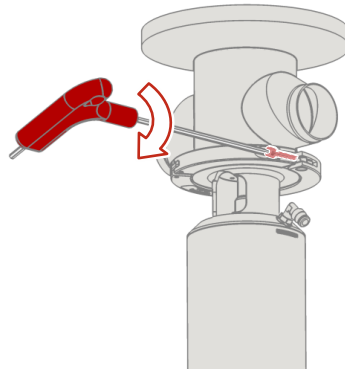

Fig.38: Loosely attaching the clamp

2. Bring the valve to the "closed" position. Move the actuator and internal assembly by hand in all directions to centre the valve seat seal in the valve seat.

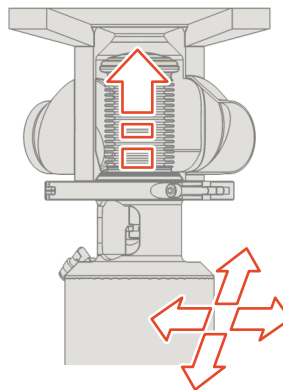

Fig.39: Centring the valve seat seal in the valve seat

3. Tighten the clamp screw. Then switch the valve 1-2 times and leave it in the "open" position. Tighten the screw again.

! Note table "Torques for clamp", see Section 10.6.3, Page 46.

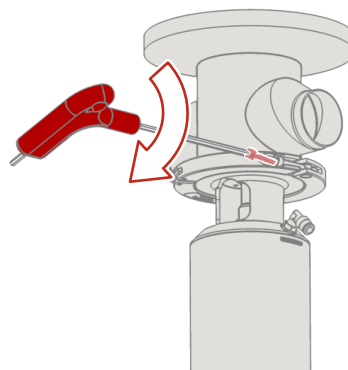

Fig.40: Centring and fastening the internal assembly

4. Test the function of the valve after assembling.

! Every possible position must be activated and held for 3-5 seconds to assure proper assembly and sealing.

→ The valve has been assembled.

### 10.6.3 Torques for clamp

Clamp screw thread size	Recommended torque [Nm]
M6	10
M8	20

## 10.7 Disassembling and Assembling the Internal Assembly

### 10.7.1 Disassembling the Internal Assembly

**⚠ Caution!**

**Danger of injury due to valve parts moved by compressed air!**

You can sustain injuries to your fingers when you put your hand into the valve while it is switching.

- ▶ Wear protective gloves for all work.
- ▶ Always exercise caution and prudence.

---

Prerequisite:

- Internal assembly and actuator have been separated from the housing, see Section 10.6, Page 43

Carry out the following steps:

1. Move the actuator to a horizontal position.  
! The T-slot in the piston rod must point upwards.

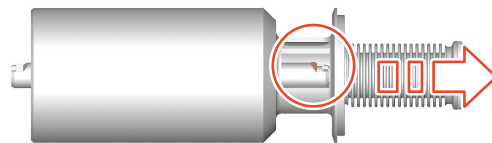

Fig.41: Aligning actuator with groove

2. Bring the actuator to the "closed" position.
3. Lift the internal assembly slightly to detach it from the T-slot on the drive spindle.

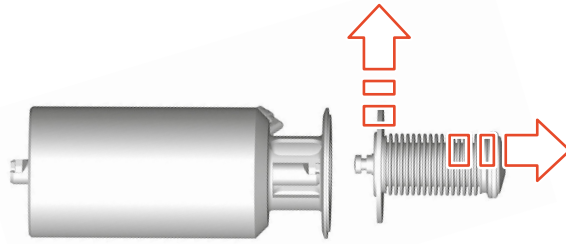

Fig.42: Unhooking the internal assembly

4. Remove the housing seal without a tool.

**! Do not damage the sealing surfaces on the housing and internal assembly.**

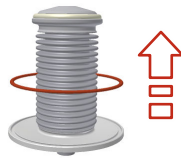

Fig.43: Removing housing gasket

→ The internal assembly has been disassembled.

## 10.7.2 Assembling the Internal Assembly

Carry out the following steps:

1. Install the internal assembly in the reverse order of disassembly, see Section 10.7.1, Page 46.

→ The internal assembly has been assembled.



### Hint!

**Statically loaded gaskets in the product-contacting area are generally not lubricated. To facilitate assembly (better gliding properties and securing against turning), this type of elastomer seal may, however, be wetted using a food-grade lubricant.**

**! Wetting elastomer gaskets is not permitted when they are used in ATEX applications!**

---

## 10.8 Removing and Installing the "Shrunk-on" Valve Seat Seal

### 10.8.1 Removing the Shrunk-on Valve Seat Seal

For information on valve seat seals, see Section 3.3, Page 18

Tools required:

- O-ring cutter
- Heat-resistant protective gloves

**⚠ Caution!**

**Health hazard due to toxic fumes!**

The O-ring cutter cuts the seal with a hot metal tip. At temperatures of more than 300 °C, toxic fumes can be released.

- ▶ Avoid directly inhaling the fumes.

**⚠ Caution!**

**Risk of injury due to hot and sharp-edged parts!**

The O-ring cutter cuts the seal with a hot metal tip. This process heats up the seal and possibly also metal parts of the valve.

- ▶ When removing the valve seat seal always wear heat-resistant protective gloves.

Carry out the following steps:

1. Place the heated metal tip of the O-ring cutter at right angles on the valve seat seal to be removed.
2. Cut through the valve seat seal at one point using the O-ring cutter.

! Pay attention not to damage the edge of the radial groove.

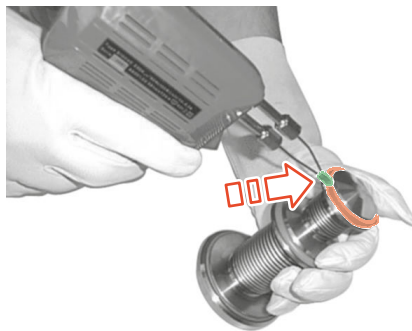

Fig.44: Cut through valve seat seal

3. Take out the cut valve seat seal.

→ The valve seat seal has been removed.

### 10.8.2 Fitting the Shrunk-on Valve Seat Seal

Tools required:

- Oven (no microwave)
- Heat-resistant protective gloves
- New valve seat seal

Carry out the following steps:

1. Heat the new valve seat seal in the oven.
  - Temperature: 140 °C (guideline value)
  - Time: 3 - 5 minutes (guideline value)

! Make sure that the seal can be deformed along the circumference without much effort. The heating time required depends on the type of oven and can vary accordingly.



Fig.45: Oven

2. Use both thumbs to press the heated valve seat seal into the radial groove at one point.

! Valve seat seals made of hard sealing materials must not be greased.

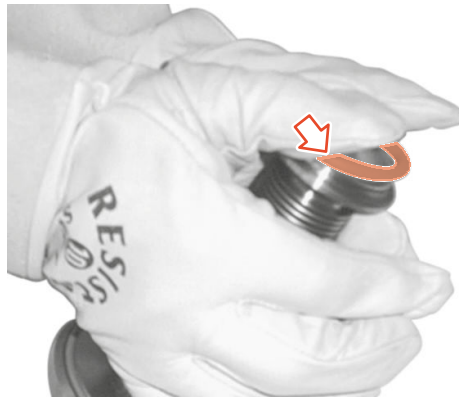

Fig.46: Place the valve seat seal into the groove

3. Then use both thumbs/palms to press the valve seat seal in place in the radial groove.

! Make sure the valve seat seal "clicks" into the radial groove. The audible clicking noise indicates that the seal has been fitted correctly.

! The valve may not be totally leak-proof after a new TEFASEP valve seat seal has been fitted. The valve seat seal will adjust itself optimally to the sealing surfaces only after the first sterilisation of the valve (see Chapter 9, Page 34). Afterwards it will ensure perfect sealing up to the maximum closing pressure or vacuum.



Fig.47: Mounting the valve seat seal

- The valve seat seal is still too rigid and cannot be mounted?
  - Heat the valve seat seal again as described in the first step.
- When mounting the valve seat seal, the seal does not "click" into place any more?
  - The valve seat seal has been overheated and can no longer be used.
  - Repeat the operation with a new valve seat seal.
  - Observe the data specified for heating the valve seat seal.
- The valve seat seal has been fitted.

## **10.9 Removing and Installing the "Divisible System" Valve Seat Seal**

### **10.9.1 Removing the Divisible Valve Seat Seal**

For information on valve seat seals, see Section 3.3, Page 18

Tools required:

- Ratchet with square socket drive ½"
- Socket wrench bit
- Vice with smooth jaws or equivalent type of protected jaws

Carry out the following steps:

1. Clamp the nut of the valve disc into the vice at the spanner flats.

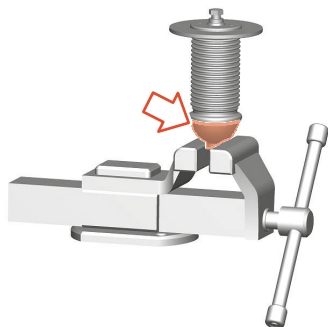

Fig.48: Clamping internal assembly

2. Use the ratchet with the wrench socket or a hex key to unscrew the spindle from the nut of the valve disc.

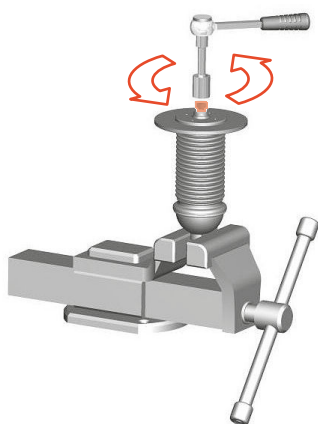

Fig.49: Releasing valve axis

3. Remove the seals from the internal assembly:
  - Seat seal (no. 1)
  - Valve disc seal on version TVT (no. 2)

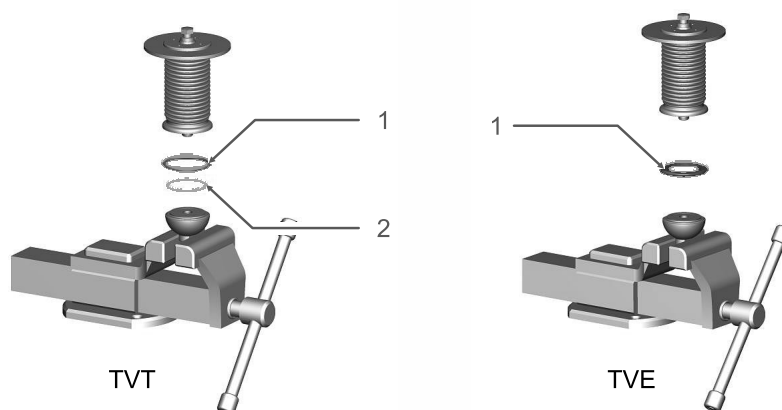

Fig.50: Removing seal(s)

TVT	Divisible valve disc, valve seat seal TEFASEP / TEFASEP shrunk
TVE	Divisible valve disc, valve seat seal EPDM

- The valve seat seal has been removed.

### 10.9.2 Fitting the Divisible Valve Seat Seal

Tools required:

- Torque wrench with wrench socket
- Vice with smooth jaws or equivalent type of protected jaws
- Food-grade lubricant PARALIQ GTE 703

Carry out the following steps:

1. The screwed-on valve seat seal is fitted in the reverse order of removal, see Section 10.9.1, Page 50.

! Prepare thermoplastic valve seat seals (TEFASEP, PTFE, ...) in the heater, see Section 10.8.2, Page 48.

! Valve seat seals made of hard sealing materials must not be greased.

! A light film of food-grade lubricant must be applied to elastomer valve seat seals before fitting.

! Note table “Torques for divisible valve discs”, see Section 10.9.3, Page 52.

→ The valve seat seal has been fitted.



**Hint!**

**Wetting elastomer gaskets is not permitted when they are used in ATEX applications!**

### 10.9.3 Torques for Divisible Valve discs

Valve size	Thread size of valve disc	Torque [Nm]
DN10	M6	9
DN15	M6	9
DN25	M8 x 1	20
DN40	M10 x 1.25	50
DN50	M12 x 1.25	60
DN65	M12 x 1.25	60
DN80	M12 x 1.25	60
DN100	M12 x 1.25	60
DN125	M20 x 1.5	70
DN150	M20 x 1.5	70

### 10.10 Carrying out the “Internal Assembly” Leak Test (Bubble Test)



**Hint!**

**Observe the inspection interval! The metal bellows must be checked for leaks as part of the annual maintenance using the pressurizing tool.**

Tools required:

- Pressurizing tool
- Compressed air supply
- Shut-off valve Ø 6 mm
- Pressure regulating valve Ø 6 mm
- Water bath

Carry out the following steps:

1. Insert the internal assembly with the T-slot of the valve spindle of the removed internal assembly into the pressurizing tool.

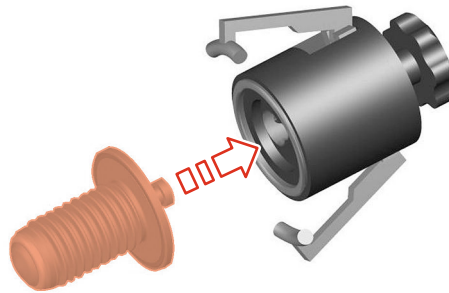

Fig.51: Hook in the internal assembly

2. Place the clamping arms of the pressurizing tool around the valve cap.

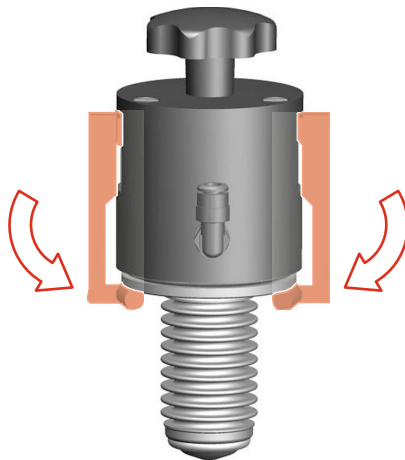

Fig.52: Attach clamping arms

3. Pull the valve cap against the seal by means of the star grip on the pressurizing tool (hand-tight).

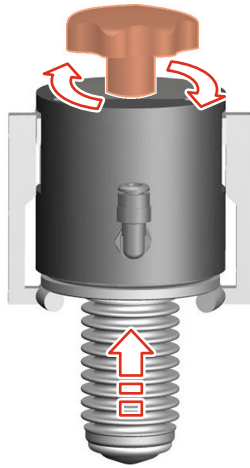

Fig.53: Secure internal assembly

4. Apply max. 3 bar of compressed air to the pressurizing tool.  
! Air pressures > 3 bar can damage the metal bellows.
5. Immerse the internal assembly in a water bath for approx. 30 seconds.  
! While the internal assembly is immersed, check the internal assembly for leaks. Leakages will be indicated by air bubbles appearing on the surface.

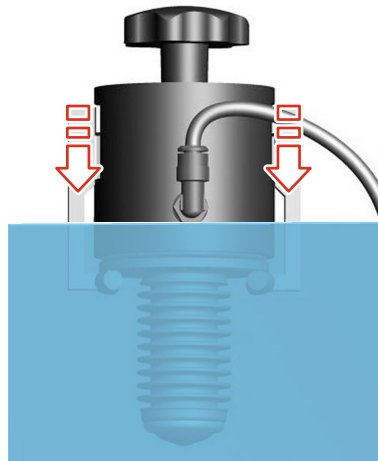

Fig.54: Water bath

6. Remove the internal assembly from the pressurizing tool in reverse order.  
→ This completes the leak test.

## 10.11 Disassembling and Assembling Actuator PA50/PA60

### 10.11.1 Disassembling Actuator PA50/PA60

**⚠ Caution!**

**Danger of injury due to spring force being released**

You may be injured if the spring tension is released in an uncontrolled manner, causing actuator parts to be moved or thrown around rapidly.

- ▶ Load and unload the spring in a controlled and slow manner.
- ▶ Wear protective gloves for all work.
- ▶ Always exercise caution and prudence.

Tools required:

- Hand-operated press
- Seeger circlip pliers
- Assembly tool for bushing PA50-60 NC/NO
- Assembly tool for O-ring

Carry out the following steps:

1. Using the bushing, press the base of the actuator downwards with the hand-operated press.

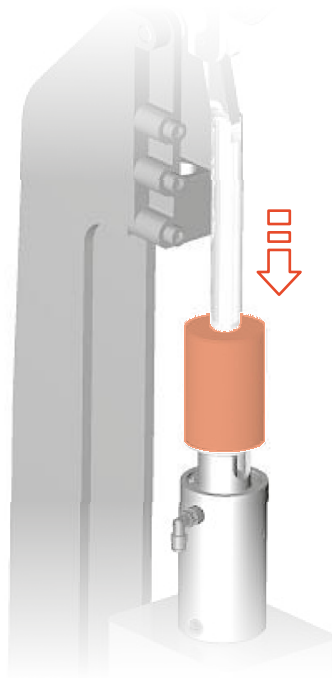

Fig.55: Lowering actuator base

2. Remove the circlip from the actuator base using the Seeger circlip pliers.

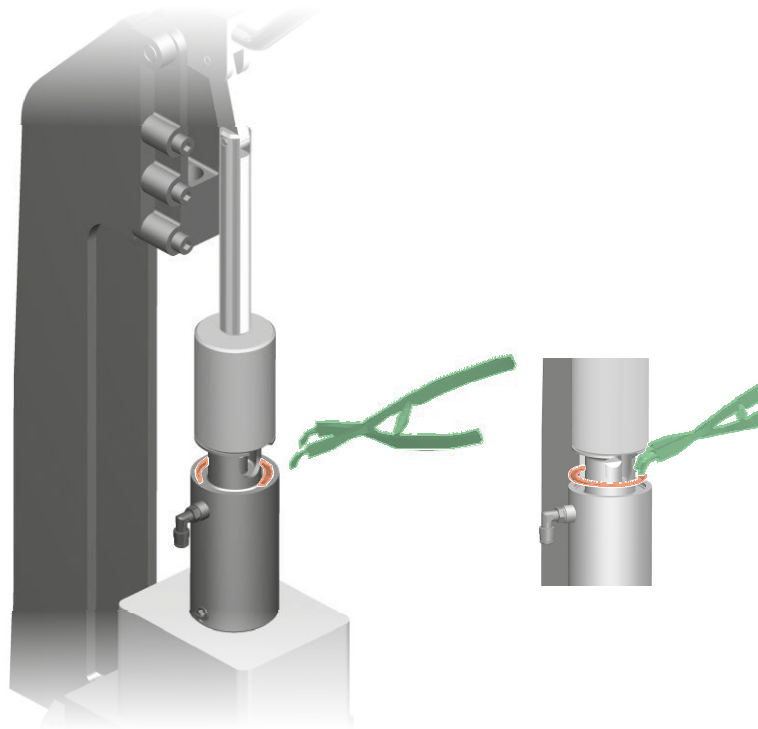

Fig.56: Removing the circlip

3. Slowly remove pressure from the actuator base.

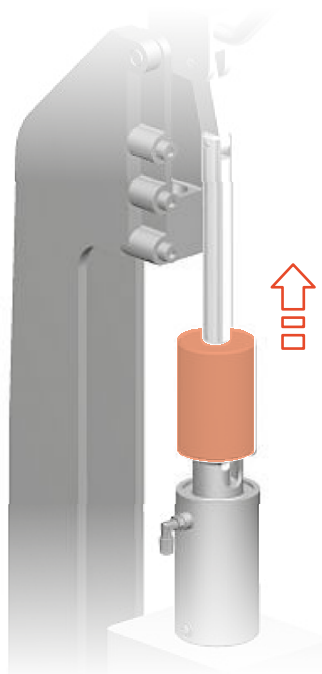

Fig.57: Removing pressure from the actuator base

4. Lift off the actuator base from the cylinder.



Fig.58: Removing actuator base

5. Perform the following step in accordance with the actuator type:
  - NC actuator: Lift out the piston rod with piston disc from the cylinder.
  - NO actuator: Carefully draw the compression spring out of the cylinder.

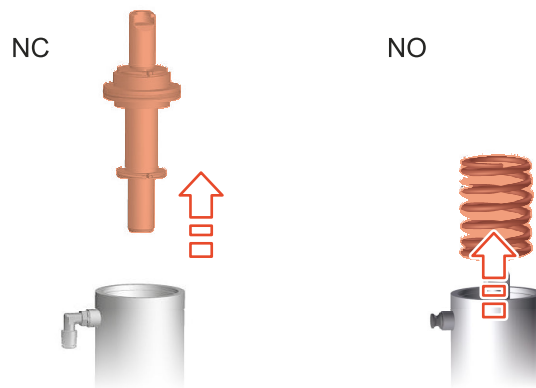

Fig.59: Lifting out upper actuator components

6. Perform the following step in accordance with the actuator type:
  - NC actuator: Carefully draw the compression spring out of the cylinder.
  - NO actuator: Lift out the piston rod with piston disc from the cylinder.

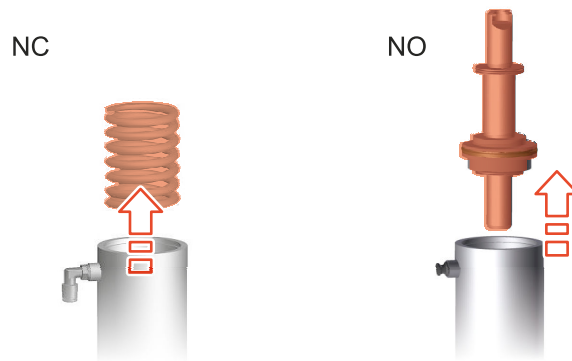

Fig.60: Lifting out lower actuator components

7. Pull the circlip out of the groove and remove both parts of the lock washer from the piston rod.

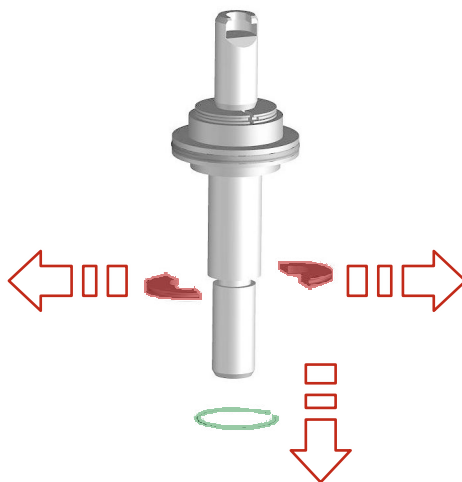

Fig.61: Removing securing elements

8. Carefully slip off the spacer sleeve and piston disc from the piston rod.  
! Pay attention to the alignment of the piston disc (asymmetrical design) already when disassembling.

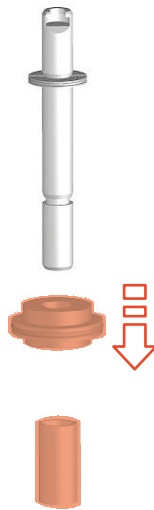

Fig.62: Pulling off actuator components

→ Actuator PA50/PA60 has been disassembled.

### 10.11.2 Assembling Actuator PA50/PA60



#### Hint!

**Pay attention to the following points when assembling the actuator:**

- Replace all visible seals.
- Thoroughly clean and check the interior cylinder contact surfaces, O-ring grooves, piston rod and piston disc.
- When changing the seals, do not damage the seal groove.
- Use only replacement seals from the seal set indicated in the list of spare parts.
- Grease all seals and the associated contact surfaces with the food-grade lubricant PARALIQ GTE 703.

---

Carry out the following steps:

1. The actuator PA50/PA60 is assembled in the reverse order of disassembly, see Section 10.11.1, Page 54.

→ Actuator PA50/PA60 has been assembled.

## 10.12 Disassembling and Assembling Actuator PA80 - PA255

### 10.12.1 Disassembling Actuator PA80 - PA255

Tools required:

- Flexible head spanner
- Assembly tool for clamping piece
- Assembly tool for spring assembly
- Assembly tool for O-ring

- Vice

**Preparing disassembly**

Carry out the following steps:

1. Bring the actuator to the non-actuated position.
2. Remove the feedback unit.
3. Attach the clamping piece assembly tool to the back of the actuator.



Fig.63: Attaching clamping piece

4. Grip the actuator in the vice using the clamping piece.

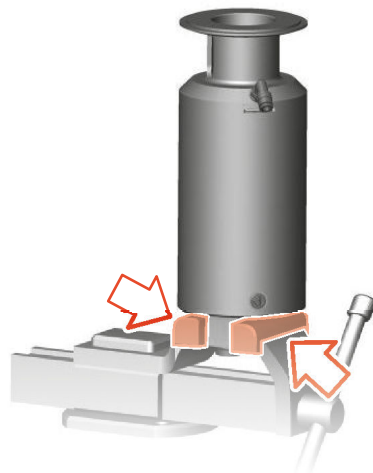

Fig.64: Clamping the actuator

→ Disassembly has been prepared

**Removing assembly spring**

Carry out the following steps:

1. Turn the actuator base counter-clockwise using a flexible head spanner, see illustration.  
! Rotate the actuator base until the assembly spring begins to move out of the slot in the cylinder.

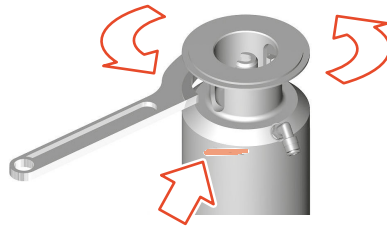

Fig.65: Releasing assembly spring

2. Turn the actuator base clockwise using the flexible head spanner.  
! Rotate the actuator base until the assembly spring can be removed.

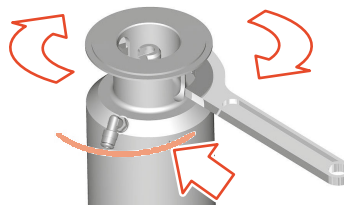

Fig.66: Unscrewing assembly spring

→ Assembly spring has been removed.

#### **PA80 - PA255: dismantling the actuator**

Carry out the following steps:

1. Lift off the actuator base from the cylinder.

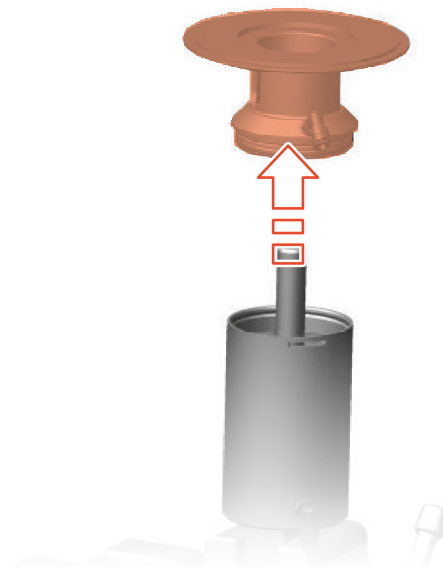

Fig.67: Removing actuator base

2. Use the assembly tool for the spring assembly to pull the spring assembly upwards and out of the cylinder.  
! Pay attention to the installation direction of the spring assembly (NC / NO direction of action) already when disassembling.

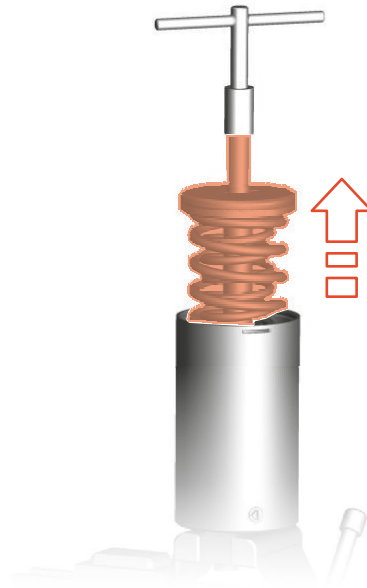

Fig.68: Lifting out spring assembly

→ Actuator has been dismantled into its individual parts.

! Opening the spring assembly is not recommended for safety reasons.

→ Actuator PA80 - PA255 has been disassembled.

### 10.12.2 Assembling Actuator PA80 - PA255



#### **Hint!**

**Pay attention to the following points when assembling the actuator:**

- Replace all visible seals.
- Thoroughly clean and check the interior cylinder contact surfaces, O-ring grooves, piston rod and piston disc.
- When changing the seals, do not damage the seal groove.
- Use only replacement seals from the seal set indicated in the list of spare parts.
- Grease all seals and the associated contact surfaces with the food-grade lubricant PARALIQ GTE 703.

---

#### **PA80 - PA255: assembling the actuator**

Carry out the following steps:

1. Assemble the actuator in the reverse order of disassembly, see Section 10.12.1, Page 59.

→ Actuator has been assembled.

#### **Installing the assembly spring**

Tools required:

- Flexible head spanner

- Slotted screwdriver

Carry out the following steps:

1. Align the actuator base relative to the cylinder housing so that the hole in the base is visible through the slot in the cylinder.

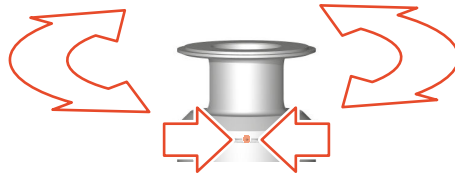

Fig.69: Aligning hole to slot

2. Insert the angled part of the assembly spring into the hole of the actuator base.

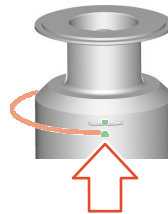

Fig.70: Hooking in the assembly spring

3. Turn the actuator base 360° counter-clockwise using a flexible head spanner.  
→ The assembly spring is pulled into the cylinder.

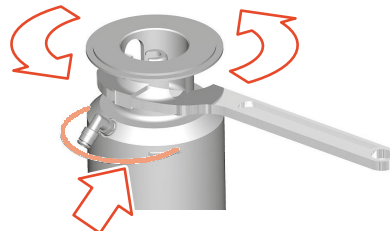

Fig.71: Screwing in the assembly spring

4. As soon as both open ends of the assembly spring are visible in the slot area, the beginning of the assembly spring must be pressed into the hole in the actuator base with a slotted screwdriver.  
! Carefully continue to turn the actuator base at the same time.

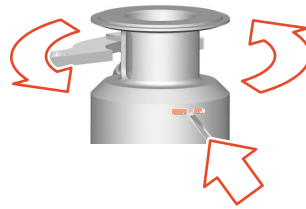

Fig.72: Fastening the assembly spring

- The assembly spring moves out of the hole when it reaches the slot in the cylinder and actuator base was turned further?
  - Continue to turn the actuator base counter-clockwise using the flexible head spanner until the hole is again located underneath the position pin of the assembly spring and the pin can be pressed in again with the slotted screwdriver.
5. Position the compressed air connection centrally over the slot in the cylinder.

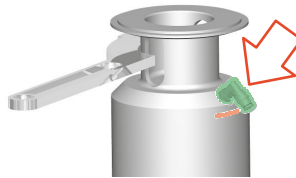

Fig.73: Placing the air connection

- Assembly spring has been fitted.
- Actuator PA80 - PA255 has been assembled.

## 10.13 Disassembling and Assembling Actuator PA80AZ - PA180AZ

### 10.13.1 Disassembling Actuator PA80AZ - PA180AZ

Tools required:

- Flexible head spanner
- Slotted screwdriver
- Assembly tool for clamping piece
- Assembly tool for spring assembly
- Assembly tool for O-ring
- Vice

#### Preparing disassembly

Carry out the following steps:

1. Prepare disassembly, see Page 60.
- Disassembly has been prepared

### Removing assembly spring

Carry out the following steps:

1. Disassemble assembly spring, see Page 60.  
→ Assembly spring has been removed.

### PA80AZ - PA180AZ: dismantling the actuator

Carry out the following steps:

1. Lift off the actuator base from the cylinder.

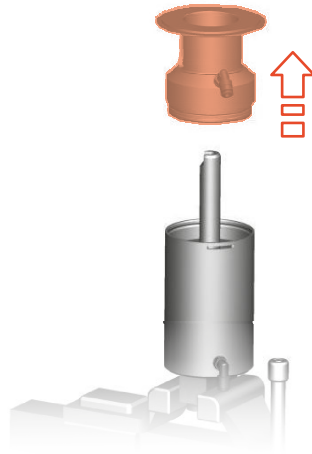

Fig.74: Removing actuator base

2. Use the assembly tool for the spring assembly to pull the spring assembly upwards and out of the cylinder.

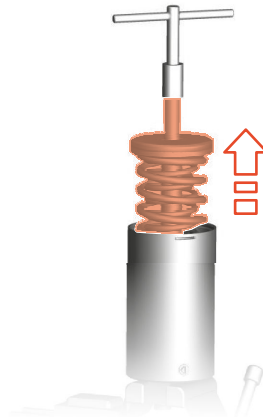

Fig.75: Lifting out spring assembly

3. Lift the circlip out of the groove with a slotted screwdriver and remove it.

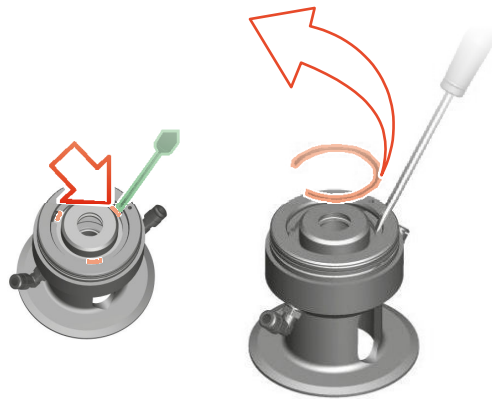

Fig.76: Removing circlip

4. Take the buffer segments out of the actuator base.

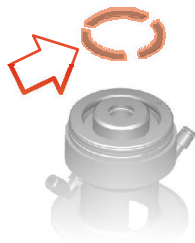

Fig.77: Removing securing elements

5. Lift the piston disc out of the actuator base.



Fig.78: Lifting out the piston disc

→ Actuator has been dismantled into its individual parts.

! Opening the spring assembly is not recommended for safety reasons.

→ Actuator PA80AZ - PA180AZ has been disassembled.

### 10.13.2 Assembling Actuator PA80AZ - PA180AZ



**Hint!**

**Pay attention to the following points when assembling the actuator:**

- Replace all visible seals.
- Thoroughly clean and check the interior cylinder contact surfaces, O-ring grooves, piston rod and piston disc.
- When changing the seals, do not damage the seal groove.
- Use only replacement seals from the seal set indicated in the list of spare parts.
- Grease all seals and the associated contact surfaces with the food-grade lubricant PARALIQ GTE 703.

Tools required:

- Flexible head spanner
- Slotted screwdriver

Carry out the following steps:

1. Assemble the actuator in the reverse order of disassembly, see Section 10.13.1, Page 64.

For details on how to connect actuator base and cylinder, see fitting the assembly spring, Section 10.12.2, Page 62.

→ Actuator PA80AZ - PA180AZ has been assembled.

### 10.14 Maintenance

Well-planned maintenance is essential to ensure a long service life of the valve. Observe the following maintenance intervals. Prepare maintenance activities well:

- Keep a maintenance log for the valve.
- Use the statistical analyses for your plant to plan maintenance intervals.

Only allow qualified maintenance staff to carry out maintenance work.



**Hint!**

**Prior to any work on the open valve, ensure that it has stopped operation, see Section 10.5, Page 42.**

The following information and values are based on the experience of GEA Aseptomag AG and apply for installations working in 2-shift operation.

Activities to be performed once a month	
Component	Activity to be performed
Valve	Visual inspection

Activities to be performed after 3 months (only after initial commissioning or after a process change)	
Component	Activity to be performed
Product contact seals	Check of mechanical parts and visual inspection of condition
Internal assembly with bellows	Check of mechanical parts and visual inspection of condition Leak test of bellows (bubble test)
Actuator	Function check
Valve	Function check
Feedback	Function check
Pneumatic connections	Check of mechanical parts and visual inspection of condition Leak test
Electrical connections	Visual inspection

Activities to be performed once a year	
Component	Activity to be performed
Product contact seals	Seal replacement
Internal assembly with bellows	Check of mechanical parts and visual inspection of condition Leak test of bellows (bubble test)
Actuator	Check of mechanical parts and visual inspection of condition Function check
Valve	Check of mechanical parts and visual inspection of condition Function check
Feedback	Check of mechanical parts and visual inspection of condition Function check
Pneumatic connections	Check of mechanical parts and visual inspection of condition Leak test
Electrical connections	Check of mechanical parts and visual inspection of condition

Activities to be performed every 5 years	
Component	Activity to be performed
Actuator	Maintenance including seal replacement

## 10.15 Checking the Feedback Unit

After completing maintenance work, check the function of the feedback unit and readjust it if necessary.

### 10.15.1 Setting the Feedback Unit

Carry out the following steps:

1. Adjust the proximity switch for detecting the non-actuated position.
2. Actuate the valve with compressed air.

If provided, adjust the proximity switch for the actuated position. For reference regarding the stroke to be expected see the "Valve Stroke" table Section 10.15.2, Page 69.

→ The feedback unit has been set.

### 10.15.2 Valve Stroke

Strokes Depending on Size		
Size	Valve stroke, standard [mm]	Valve stroke, extended [mm]
DN 10	4	6
DN 15	4	6
DN 25	6	10
DN 40	10	12.5
DN 50	16	25
DN 65	16	25
DN 80	25	--
DN 100	25	--
DN 125	35	--
DN 150	35	--
ISO 17.2	4	6
ISO 21.3	4	6
ISO 33.7	6	10
ISO 48.3	10	12.5
ISO 60.3	16	25
ISO 76.1	16	25
ISO 88.9	25	--
ISO 114.3	25	--
1/2" OD	4	6
3/4" OD	4	6

Strokes Depending on Size		
Size	Valve stroke, standard [mm]	Valve stroke, extended [mm]
1" OD	6	10
1 1/2" OD	10	12.5
2" OD	16	25
2 1/2" OD	16	25
3" OD	25	--
4" OD	25	--
6" OD	35	--

## 11 Alarms

### 11.1 Malfunctions and remedies

#### Notice!

#### **Warning of damage to property/loss of product**

Ignoring malfunctions may cause considerable damage to property and loss of product. The safe operation of the valve in the event of a fault can no longer be taken for granted and in the worst case can result in a loss of sterility in the process.

- ▶ Make sure that malfunctions are quickly identified and promptly fixed.

In the event of malfunctions immediately deactivate the valve and secure it against inadvertent reactivation. Malfunctions may only be remedied by qualified staff, who must observe the safety instructions. For malfunctions not listed in the table below, contact the manufacturer.

<b>Malfunction</b>	<b>Cause</b>	<b>Remedy</b>
Medium is leaking from the clamp.	The housing seal is not fitted correctly.	Fit the housing seal correctly or replace it if damaged.
Medium is leaking from the leakage holes of the internal assembly.	The metal bellows on the internal assembly is defective.	<ul style="list-style-type: none"> <li>• Replace the complete internal assembly.</li> <li>• Send the defective internal assembly to the manufacturer for repair.</li> </ul>
During pressure testing of the internal assembly, air escapes from the metal bellows.	The metal bellows on the internal assembly is defective.	<ul style="list-style-type: none"> <li>• Replace the complete internal assembly.</li> <li>• Send the defective internal assembly to the manufacturer for repair.</li> </ul>
Leak at the valve seat.	<ul style="list-style-type: none"> <li>• The valve seat seal is defective.</li> <li>• Product deposits on the valve seat.</li> </ul>	<ul style="list-style-type: none"> <li>• Replace the valve seat seal.</li> <li>• Check the housing.</li> </ul>
The maximum valve stroke is not reached when the valve is actuated pneumatically.	Leakage in the actuator.	<ul style="list-style-type: none"> <li>• Check the sealing surfaces in the actuator for damage.</li> <li>• Replace the seals.</li> </ul>

Malfunction	Cause	Remedy
Valve feedback not correct.	<ul style="list-style-type: none"> <li>• The feedback unit is not fitted correctly.</li> <li>• The proximity switch is not in the correct position or is defective.</li> <li>• Fault in the power supply.</li> </ul>	<ul style="list-style-type: none"> <li>• Check that the feedback unit has been fitted correctly.</li> <li>• Check the position of the proximity switch and re-adjust if necessary.</li> <li>• Check the wiring.</li> </ul>
Actuator is filling with water.	<ul style="list-style-type: none"> <li>• Unfavourable installation position of the vent screw on the actuator.</li> <li>• Unfavourable effect of the exterior cleaning of the plant.</li> </ul>	<ul style="list-style-type: none"> <li>• If possible, position the vent screw so that it faces downwards.</li> <li>• When the valve is installed in the vertical position, ensure that the vent screw faces away from the cleaning direction if possible.</li> </ul>
The TEFASEP valve seat seal is not tight after commissioning or maintenance.	<ul style="list-style-type: none"> <li>• The valve seat seal has not been fitted correctly.</li> <li>• In case of a new seal: The valve has not been actuated during/ immediately after sterilisation.</li> </ul>	<ul style="list-style-type: none"> <li>• Fit the valve seat seal properly.</li> <li>• Actuate the valve during/ immediately after sterilisation.</li> </ul>

## 12 Decommissioning

### 12.1 Safety instructions

For shutting down, the following principles apply:

- Switch off the compressed air.
- Switch off the valve via the main switch.
- Padlock the main switch (if fitted) in the off position to prevent it from being switched back on. The key to the padlock must be deposited with the person responsible until the machine is restarted.
- For longer periods of standstill, observe the storage conditions, see Section 4.1, Page 19.

### 12.2 Disposal

#### 12.2.1 General notes

Dispose of the valve in an environmentally friendly manner. Observe the statutory waste disposal regulations applicable at the place of installation.

The valve is made of the following materials:

- Metals
- Synthetic materials
- Electronic parts
- Lubricants containing oil and grease

Separate the different materials and dispose of them correctly sorted. Also observe the instructions regarding disposal in the operating instructions for the individual components.

## 13 Appendix

### 13.1 Lists

#### 13.1.1 Abbreviations and terms

Abbreviation	Explanation
°	Symbol for the grade of a scale [degrees] All degree data is assumed to be angle degrees unless explicitly specified otherwise.
°C	Unit of measurement of temperature [degree Celsius]
°F	Unit of measurement of temperature [degree Fahrenheit]
AISI	American Iron and Steel Institute; material designation
ATEX	Atmosphères Explosibles Directive of the European Union on explosion protections
AZ	Venting cylinder
bar	Unit of measurement of pressure [bar] All pressure data is assumed to be gauge pressure [barg] unless explicitly specified otherwise.
CFR	Code of Federal Regulations; collection of US federal regulations
d	Short name for diameter
DIN	German standard issued by DIN (Deutsches Institut für Normung e.V., German Institute for Standardisation)
dm <sup>3</sup>	Unit of measurement of volume [cubic decimetre]
DN	DIN nominal width
EN	European Standard
EPDM	Ethylene Propylene Diene Rubber Material designation, short designation according to DIN/ISO 1629
FDA	U.S. Food and Drug Administration Food monitoring and drug administration in the USA
FEP	Fluorinated ethylene propylene; material designation, short name
H <sub>2</sub> O <sub>2</sub>	Hydrogen peroxide; chemical formula
ISO	International standard of the International Organization for Standardization
ACSC	Air-closing/spring-opening; direction of action air
m/s	Unit of measurement of speed/velocity [metres per second]
min.	Unit of measurement of time [minute]
mm	Unit of measurement of length [millimetre]
µm	Unit of measurement of length [micrometre]
NC	Normally Closed; direction of action spring-closing/air-opening

---

<b>Abbreviation</b>	<b>Explanation</b>
Nm	Unit of measurement of work [newton metre] Unit of torque 1 Nm = 0.737 lbft Pound-Force (lb) + Feet (ft)
NO:	Normally Open; direction of action air-closing/spring-opening
OD	Outside diameter; short name for outside diameter for inch tubes according to DIN 11866-C
PA	Pneumatic actuator
PTFE	Polytetrafluoroethylene Material designation, short designation according to DIN/ISO 1629
AF	Width across flats; indicates the size of spanners
TEFASEP	Sealing material for the valve seat seal
T.VIS	Tuchenhagen Valve Information System
TIG	Tungsten inert gas welding



## We live our values.

Excellence · Passion · Integrity · Responsibility · GEA-versity

GEA Group is a global engineering company with multi-billion euro sales and operations in more than 50 countries. Founded in 1881, the company is one of the largest providers of innovative equipment and process technology. GEA Group is listed in the STOXX® Europe 600 Index.

### GEA Switzerland

GEA Aseptomag AG  
Industrie Neuhof 28  
CH-3422 Kirchberg

Tel +41 (0)34 426 29 29  
Fax +41 (0)34 426 29 28

[service.aseptomag@gea.com](mailto:service.aseptomag@gea.com)  
[gea.com](http://gea.com)