

Ammonium Sulfate

Fertilizer Industry



GEA Messo PT: over half a century of innovation

In industrial mass crystallization GEA Messo PT has established itself as leading plant supplier. The in-depth knowledge of over a 1,000 plants and continuous research and development have kept us in the forefront for the design and supply of crystallization plants. Good examples of the many aspects of crystallization can be found in our various plants for the mass crystallization of ammonium sulfate. GEA Messo PT is one of the few companies with experience in all these applications and capable of helping you in making the best choice with regard to types of crystallizers, types of crystallization and the many aspects of product quality.

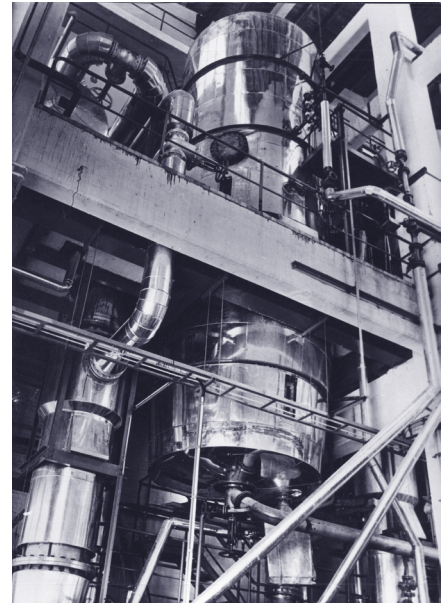

Types of crystallizers

The generation of fines that act as the seeds for new crystals and the removal of fines are the main processes that determine the size of the crystals that can be produced. There are three basically different types of crystallizers the forced circulation (FC), the turbulence or draft tube baffled (DTB) and the fluidized bed or Oslo crystallizer. GEA Messo PT supplies all these types of crystallizers.

In the FC crystallizer the entire contents of the crystallizer are completely mixed and pass the circulation pump and heat exchanger hundred times per hour. This gives most mechanical stress on the crystals and leads to the formation of a large amount of fragments that act as seed crystals. These fines grow to many and thus smaller product crystals. In the DTB crystallizer the crystal suspension does not pass the heat exchanger and as a result the power input of the circulation pump is a factor ten lower than for the FC crystallizer leading to much lower fines generation. In addition, fines which are present are taken out of the crystallizer through a clarifying zone and are dissolved as a result of the heating in the heat exchanger. These effects lead to a crystal size which is 3-4 times larger than what can be achieved in the FC type. In the Oslo crystallizer there is no pump which is in contact with the crystal suspension but the crystals are kept in a fluidized bed. As a result the mechanical stress on the crystals is even lower. For many products this leads to the largest possible crystals, but for ammonium sulfate the crystal size that can be reached is only slightly larger than with the DTB and if the plant is overloaded the crystal size collapses because the crystallizer will start to act similar to an FC crystallizer.

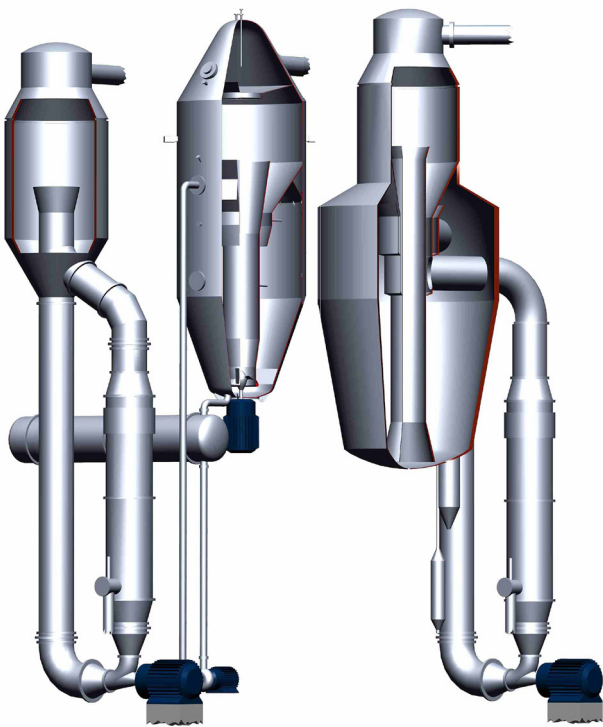

FC, DTB, Oslo type crystallizer

Ammonium sulfate background

Contrary to urea or MAP that are produced as a melt, ammonium sulfate is produced as crystals.

Ammonium Sulfate (AS) industrial production began over a century ago, as by-product in gas cleaning in coke and coal gasification plants. The production of caprolactam (CPL), Methyl Methacrylate (MMA) and acrylonitrile yield a large quantity of AS as a by-product. In the nineteen-sixties the production of these chemicals increased strongly and growth leveled off in the nineteen-eighties. This source now accounts for 60-70% of the AS produced in the world. Other sources for ammonium sulfate are for example the purge of gas washers e.g. from large urea prilling towers or regeneration liquids from continuous ion exchange systems.

In addition, from the early twentieth century on, some AS has been produced through the reaction of ammonia and sulfuric acid. This was especially the case in countries where importation of urea fertilizer was difficult due to lack of foreign currency. The present estimated worldwide production of AS is 17 million tons per year.

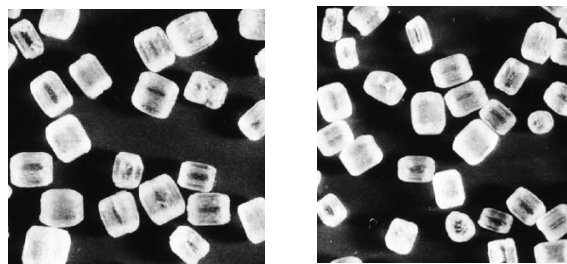

Ammonium sulfate crystallizer in caprolactam industry

Ammonium sulfate as fertilizer

As a fertilizer, AS supplies two fundamental nutrients: nitrogen and sulfur. Of the total amount of nitrogen fertilizers only 4% is ammonium sulfate. The main reason for this is the relatively low Nitrogen content of AS, as compared to that of for instance Urea (21% and 45% respectively). As a result, the production of AS has been controlled primarily by the needs of other industrial processes, rather than by fertilizer market demands.

Recently, the world-wide supply of AS has increased somewhat, in part due to the production of AS by direct reaction crystallization from (spent) sulfuric acid and ammonia. The additional AS supply has been absorbed quickly in the marketplace, because of a general increase in fertilizer demand and an increased need for sulfur nutrition in particular.

The additional production capacity of AS has not been sufficient to fulfill the market requirements, however, and naturally, this gap in the supply-demand relationship has led to a rise in AS prices. As one might expect, the price of AS varies with the various types of product quality available. The largest disparity is in connection to particle size where up to three times higher price has been reported between the price of <1 mm crystals and that of "granular" (2-3 mm) crystals. This price differential can be a strong incentive to produce large crystals.

Ammonium sulfate crystallization overview

In AS crystallization, one needs to distinguish between reaction crystallization and evaporative crystallization. In addition the performance of the different types of crystallizers needs to be considered.

In reaction crystallization, such as that of AS from sulfuric acid and ammonia, both the reaction that creates the supersaturation of the solute, and the subsequent crystallization of the solute, occur inside the crystallizer vessel. The heat of dissolution and reaction for AS, when using reasonably concentrated reactants, is sufficient to operate a reaction AS crystallizer without any external energy source for evaporation. The supersaturation profile and the AS crystallization kinetics, as well as the method of operation of such a crystallizer are different from those of a classic evaporative crystallizer. In an evaporative unit, the feedstock is brought in undersaturated and a heater needs to be operated in conjunction with crystallizer, to evaporate the water in the feedstock. The majority of the AS crystallizers, estimated at 80-90%, are operated in the evaporative mode.

The general trend is that reactive crystallization produces smaller crystals but has an energetic advantage over evaporative crystallization. A summary of performance of the available combinations of crystallizer type and crystallization type is given in table. 1. AS fertilizer is priced on the basis of its size, with granular material commanding considerable premium over standard grade. The table indicates under what conditions this is possible. If this is needed classifiers and sieves are made a part of our overall design.

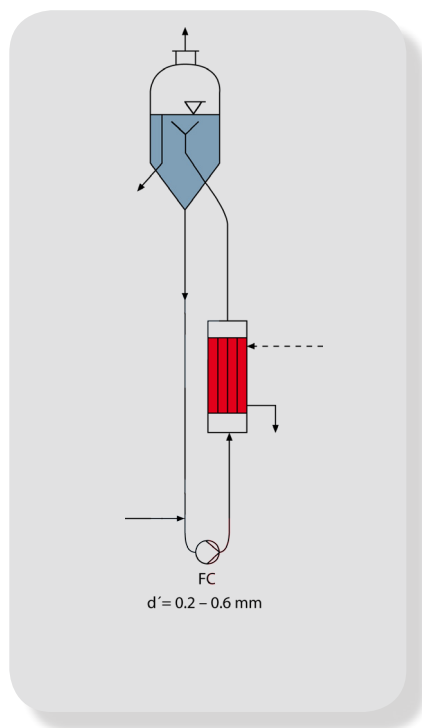

1. Forced circulation (FC) crystallizer

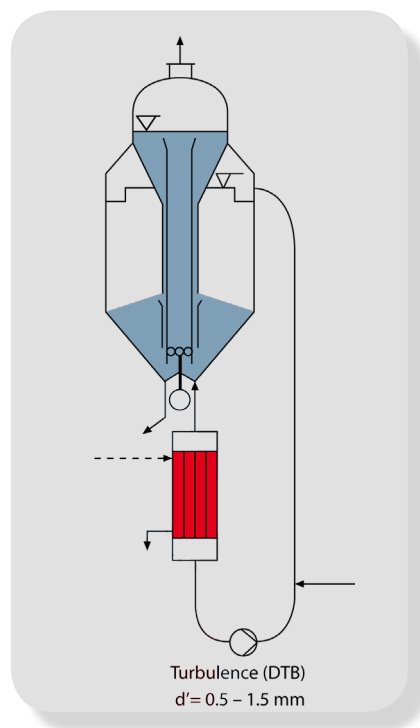

2. Turbulence (DTB) crystallizer

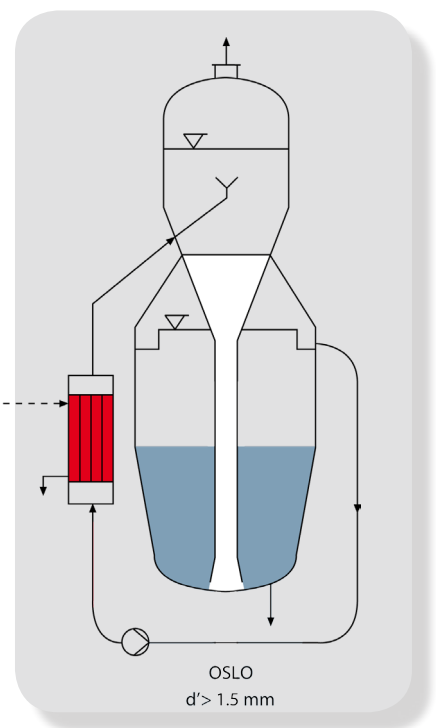

3. OSLO crystallizer

Forced circulation, EC

crystal size D_{50} 0.6-1 mm
easy to operate, low capital cost
small plants
plants or sections with
high impurities for yield increase

Draft Tube Baffled DTB, EC

crystal size d_{50} 2-2.4 mm
at the moment method of choice
80% of recent GEA references DTB
medium to large plants
cycling tendency for crystal size

Oslo, EC

crystal size d_{50} 1.2-2.6 mm
in practice often running as FC
large plants
cycling tendency for crystal size
crystallizers 2-3 times larger
than equivalent DTB
conversion to DTB

Forced circulation, RC

crystal size d_{50} 0.4-0.6mm
easy to operate, low capital cost
small plants
low energy cost, single stage
•

Draft Tube Baffled DTB, RC

crystal size d_{50} 0.8-1.4 mm
medium to large plants
ammonia injection critical

Oslo, RC

crystal size d_{50} 0.9-1.1 mm
large plants
easy ammonia injection
opportunity to separate light
fractions like lactam oil

Table 1: summary of performance

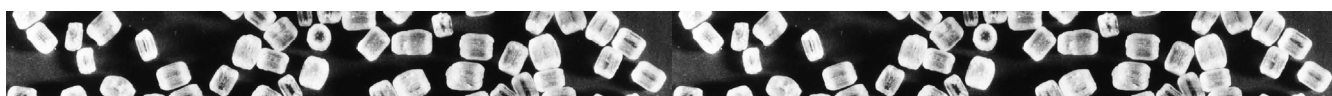

Granular ammonium sulfate

Energy costs

Reaction crystallization capacity 145,000 tpa



- In the reaction crystallization ammonia and sulfuric acid (concentrated or in a waste stream) are combined inside the crystallizer to form AS. The reaction heat will drive the evaporation.
- In evaporation crystallization formation of AS requires removal of water from the feed solution. The crystallizer is heated with steam for the evaporation and the energy costs are the main portion of the running costs.

To minimize the energy cost in evaporation units we supply energy-efficient systems like Mechanical Vapor Recompression or multiple-effect evaporators.

Cyclical variations in the crystal size

Typical to the nature of any crystallizer that produces large crystals is an increased tendency for the D₅₀ of the produced crystals to cycle. The general reason for this is that it is extremely difficult to balance the actual crystal surface area in the crystallizer with the surface area required for orderly deposition of the mass from the supersaturation, on the crystals in the crystallizer.

In a classic example of cycling D₅₀, the fines destruction capacity of a DTB crystallizer exceeds its nucleation rate, and may force the unit to operate in a “feast-or-famine” mode: as the D₅₀ increases, the available surface for de-supersaturation by growth of the existing crystals decreases to a critical point, spontaneous nucleation occurs and a new generation of seed

crystals is formed in massive numbers, which reduces the unit’s D₅₀. The frequency of the cycle, depending on the design and operating characteristics of the crystallizer, can range from several hours up to several days. The cycling effect may be less noticeable in installations with many crystallizers operated in parallel, and where the D₅₀ measured is the average from all the units combined.

A corrective method which is practiced in the last generation of crystallizers is to measure the CSD, determine from it the available crystal surface area, and when the surface area decreases (the crystals become too large) add to the crystallizer relatively fine, well defined crystals from an external source.

Upgrading

For many decades, the Oslo crystallizer was the choice for producing large crystals; over time, in most existing installations, the productivity of these units has been increased greatly over their design point, with a commensurate decrease in the product crystal size. GEA Messo PT can improve the particle size made by these units by converting them to the DTB configuration. This upgrade can lead to the potential of improved product pricing, without a penalty on production rates.



DTB crystallizer in the USA

Ammonium sulfate as by-product

In the industrial practice the ammonium sulfate is usually a by-product. These solutions have a lot of impurities from different sources.

- organic impurities from the caprolactam or methyl metacrylate production or
- inorganic impurities from e.g. waste acids in a reaction crystallization or urea in gas washing liquids.

The combined effects of these impurities are complex and influence the purity and the crystal shape and size. GEA Messo PT with its experience in evaporation and crystallization knows where the general limits for such plants are. Our dedicated centers for crystallization research will investigate for your specific case all design parameters as a basis for our engineering and for any new development you may need.

GEA Messo PT laboratory

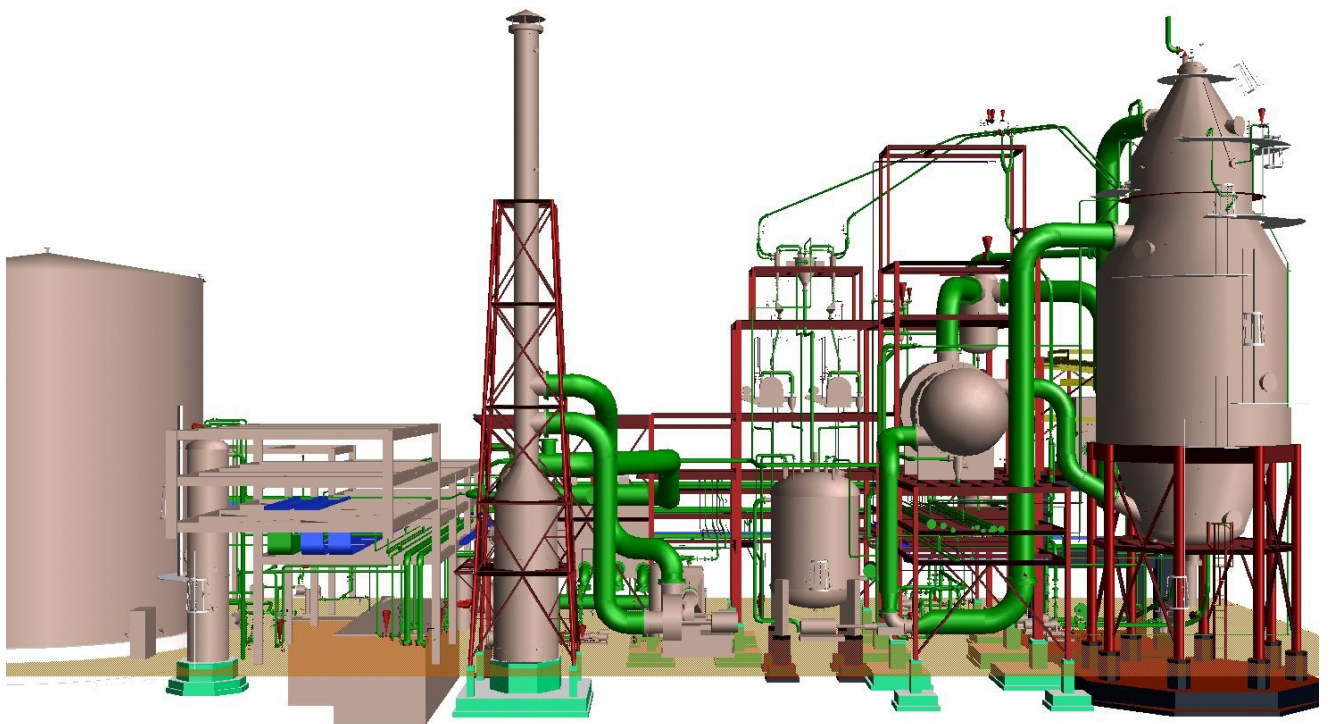

Ammonium sulfate crystallizer in caprolactam industry

The right choice for you

GEA Messo PT has a reference list of over fifty successful ammonium sulfate crystallizer installations around the world, has several patents on associated process and equipment features, and continues to work hard on improving its technology for the benefit of its clients.

For the crystallization of ammonium sulfate, GEA Messo PT is the worldwide supplier that can offer all options available: reactive and evaporation crystallization, all types of crystallizers, energy conservation systems, systems for handling of impurities in complex feed streams. With this background we are ready to help you make the right choices leading to a successful project.



Contact us at:
www.gea-messo-pt.com



Process Engineering

GEA Messo PT

Germany:

Friedrich-Ebert-Strasse 134
47229 Duisburg
Tel. +49 2065-903 0, Fax +49 2065-903 199
info.geamesso.de@geagroup.com

The Netherlands:

De Beverspijken 7b
5221 EE 's-Hertogenbosch
Tel. +31 73 6390 390, Fax +31 73 6312 349
sales.niropt.nl@geagroup.com